

Programmable Controller

MELSEC  series

MELSEC-Q
QD74MH Positioning Module
User's Manual (Details)

-QD74MH8
-QD74MH16

● SAFETY PRECAUTIONS ●

(Please read these instructions before using this equipment.)

Before using this product, please read this manual and the relevant manuals introduced in this manual carefully and pay full attention to safety to handle the product correctly.

Refer to the Users manual of the QCPU module to use for a description of the PLC system safety precautions.

In this manual, the safety instructions are ranked as "DANGER" and "CAUTION".

 **DANGER**

Indicates that incorrect handling may cause hazardous conditions, resulting in death or severe injury.

 **CAUTION**

Indicates that incorrect handling may cause hazardous conditions, resulting in medium or slight personal injury or physical damage.

Depending on circumstances, procedures indicated by  CAUTION may also be linked to serious results.

In any case, it is important to follow the directions for usage.

Please save this manual to make it accessible when required and always forward it to the end user.

For Safe Operations

1. Prevention of electric shocks

DANGER

- Never open the front case or terminal covers while the power is ON or the unit is running, as this may lead to electric shocks.
- Never run the unit with the front case or terminal cover removed. The high voltage terminal and charged sections will be exposed and may lead to electric shocks.
- Never open the front case or terminal cover at times other than wiring work or periodic inspections even if the power is OFF. The insides of the module and servo amplifier are charged and may lead to electric shocks.
- Completely turn off the externally supplied power used in the system before mounting or removing the module, performing wiring work, or inspections. Failing to do so may lead to electric shocks.
- When performing wiring work or inspections, turn the power OFF, wait at least ten minutes, and then check the voltage with a tester, etc. Failing to do so may lead to electric shocks.
- Be sure to ground the module, servo amplifier and servomotor (Ground resistance : 100 Ω or less). Do not ground commonly with other devices.
- The wiring work and inspections must be done by a qualified technician.
- Wire the units after installing the module, servo amplifier and servomotor. Failing to do so may lead to electric shocks or damage.
- Never operate the switches with wet hands, as this may lead to electric shocks.
- Do not damage, apply excessive stress, place heavy things on or sandwich the cables, as this may lead to electric shocks.
- Do not touch the module, servo amplifier, servomotor connector or terminal blocks while the power is ON, as this may lead to electric shocks.
- Do not touch the built-in power supply, built-in grounding or signal wires of the module and servo amplifier, as this may lead to electric shocks.

2. For fire prevention

CAUTION

- Install the module, servo amplifier, servomotor and regenerative resistor on incombustible. Installing them directly or close to combustibles will lead to fire.
- If a fault occurs in the module or servo amplifier, shut the power OFF at the servo amplifier's power source. If a large current continues to flow, fire may occur.
- When using a regenerative resistor, shut the power OFF with an error signal. The regenerative resistor may abnormally overheat due to a fault in the regenerative transistor, etc., and may lead to fire.
- Always take heat measures such as flame proofing for the inside of the control panel where the servo amplifier or regenerative resistor is installed and for the wires used. Failing to do so may lead to fire.
- Do not damage, apply excessive stress, place heavy things on or sandwich the cables, as this may lead to fire.

3. For injury prevention

CAUTION

- Do not apply a voltage other than that specified in the instruction manual on any terminal. Doing so may lead to destruction or damage.
- Do not mistake the terminal connections, as this may lead to destruction or damage.
- Do not mistake the polarity (+ / -), as this may lead to destruction or damage.
- Do not touch the heat radiating fins of module or servo amplifier, regenerative resistor and servomotor, etc., while the power is ON and for a short time after the power is turned OFF. In this timing, these parts become very hot and may lead to burns.
- Always turn the power OFF before touching the servomotor shaft or coupled machines, as these parts may lead to injuries.
- Do not go near the machine during test operations or during operations such as teaching. Doing so may lead to injuries.

4. Various precautions

Strictly observe the following precautions. Mistaken handling of the unit may lead to faults, injuries or electric shocks.

(1) System structure

CAUTION

- Always install a leakage breaker on the module and servo amplifier power source.
- If installation of an electromagnetic contactor for power shut off during an error, etc., is specified in the instruction manual for the servo amplifier, etc., always install the electromagnetic contactor.
- Install the emergency stop circuit externally so that the operation can be stopped immediately and the power shut off.
- Use the module, servo amplifier, servomotor and regenerative resistor with the correct combinations listed in the instruction manual. Other combinations may lead to fire or faults.
- Use the CPU module, base unit and positioning module with the correct combinations listed in the instruction manual. Other combinations may lead to faults.
- If safety standards (ex., robot safety rules, etc.,) apply to the system using the module, servo amplifier and servomotor, make sure that the safety standards are satisfied.
- Construct a safety circuit externally of the module or servo amplifier if the abnormal operation of the module or servo amplifier differ from the safety directive operation in the system.
- In systems where coasting of the servomotor will be a problem during the forced stop, emergency stop, servo OFF or power supply OFF, use dynamic brakes.
- Make sure that the system considers the coasting amount even when using dynamic brakes.
- In systems where perpendicular shaft dropping may be a problem during the forced stop, emergency stop, servo OFF or power supply OFF, use both dynamic brakes and electromagnetic brakes.
- The dynamic brakes must be used only on errors that cause the forced stop, emergency stop, or servo OFF. These brakes must not be used for normal braking.
- The brakes (electromagnetic brakes) assembled into the servomotor are for holding applications, and must not be used for normal braking.

CAUTION

- The system must have a mechanical allowance so that the machine itself can stop even if the stroke limits switch is passed through at the max. speed.
- Use wires and cables that have a wire diameter, heat resistance and bending resistance compatible with the system.
- Use wires and cables within the length of the range described in the instruction manual.
- The ratings and characteristics of the parts (other than module, servo amplifier and servomotor) used in a system must be compatible with the module, servo amplifier and servomotor.
- Install a cover on the shaft so that the rotary parts of the servomotor are not touched during operation.
- There may be some cases where holding by the electromagnetic brakes is not possible due to the life or mechanical structure (when the ball screw and servomotor are connected with a timing belt, etc.). Install a stopping device to ensure safety on the machine side.

(2) Parameter settings and programming

CAUTION

- Set the parameter values to those that are compatible with the module, servo amplifier, servomotor and regenerative resistor model and the system application. The protective functions may not function if the settings are incorrect.
- The regenerative resistor model and capacity parameters must be set to values that conform to the operation mode, servo amplifier and servo power supply module. The protective functions may not function if the settings are incorrect.
- Set the mechanical brake output and dynamic brake output validity parameters to values that are compatible with the system application. The protective functions may not function if the settings are incorrect.
- Set the stroke limit input validity parameter to a value that is compatible with the system application. The protective functions may not function if the setting is incorrect.
- Set the servomotor encoder type (increment, absolute position type, etc.) parameter to a value that is compatible with the system application. The protective functions may not function if the setting is incorrect.
- Set the servomotor capacity and type (standard, low-inertia, flat, etc.) parameter to values that are compatible with the system application. The protective functions may not function if the settings are incorrect.
- Set the servo amplifier capacity and type parameters to values that are compatible with the system application. The protective functions may not function if the settings are incorrect.
- Use the program commands for the program with the conditions specified in the instruction manual.
- Set the sequence function program capacity setting, device capacity, latch validity range, I/O assignment setting, and validity of continuous operation during error detection to values that are compatible with the system application. The protective functions may not function if the settings are incorrect.

CAUTION

- Some devices used in the program have fixed applications, so use these with the conditions specified in the instruction manual.
- The input devices and data registers assigned to the link will hold the data previous to when communication is terminated by an error, etc. Thus, an error correspondence interlock program specified in the instruction manual must be used.
- Use the interlock program specified in the intelligent function module's instruction manual for the program corresponding to the intelligent function module.

(3) Transportation and installation

CAUTION

- Transport the product with the correct method according to the mass.
- Use the servomotor suspension bolts only for the transportation of the servomotor. Do not transport the servomotor with machine installed on it.
- Do not stack products past the limit.
- When transporting the module or servo amplifier, never hold the connected wires or cables.
- When transporting the servomotor, never hold the cables, shaft or detector.
- When transporting the module or servo amplifier, never hold the front case as it may fall off.
- When transporting, installing or removing the module or servo amplifier, never hold the edges.
- Install the unit according to the instruction manual in a place where the mass can be withstood.
- Do not get on or place heavy objects on the product.
- Always observe the installation direction.
- Keep the designated clearance between the module or servo amplifier and control panel inner surface or the module and servo amplifier, module or servo amplifier and other devices.
- Do not install or operate modules, servo amplifiers or servomotors that are damaged or that have missing parts.
- Do not block the intake/outtake ports of the servo amplifier and servomotor with cooling fan.
- Do not allow conductive matter such as screw or cutting chips or combustible matter such as oil enter the module, servo amplifier or servomotor.
- The module, servo amplifier and servomotor are precision machines, so do not drop or apply strong impacts on them.
- Securely fix the module, servo amplifier and servomotor to the machine according to the instruction manual. If the fixing is insufficient, these may come off during operation.
- Always install the servomotor with reduction gears in the designated direction. Failing to do so may lead to oil leaks.

⚠ CAUTION

- Store and use the unit in the following environmental conditions.

Environment	Conditions	
	Module/Servo amplifier	Servomotor
Ambient temperature	According to each instruction manual.	0°C to +40°C (With no freezing) (32°F to +104°F)
Ambient humidity	According to each instruction manual.	80% RH or less (With no dew condensation)
Storage temperature	According to each instruction manual.	-20°C to +65°C (-4°F to +149°F)
Atmosphere	Indoors (where not subject to direct sunlight). No corrosive gases, flammable gases, oil mist or dust must exist	
Altitude	1000m (3280.84ft.) or less above sea level	
Vibration	According to each instruction manual	

- When coupling with the servomotor shaft end, do not apply impact such as by hitting with a hammer. Doing so may lead to detector damage.
- Do not apply a load larger than the tolerable load onto the servomotor shaft. Doing so may lead to shaft breakage.
- When not using the module for a long time, disconnect the power line from the module or servo amplifier.
- Place the module and servo amplifier in static electricity preventing vinyl bags and store.
- When storing for a long time, please contact with our sales representative.
Also, execute a trial operation.
- Make sure that the connectors for the servo amplifier and peripheral devices have been securely installed until a click is heard.
Not doing so could lead to a poor connection, resulting in erroneous input and output.

(4) Wiring

⚠ CAUTION

- Correctly and securely wire the wires. Reconfirm the connections for mistakes and the terminal screws for tightness after wiring. Failing to do so may lead to run away of the servomotor.
- After wiring, install the protective covers such as the terminal covers to the original positions.
- Do not install a phase advancing capacitor, surge absorber or radio noise filter (option FR-BIF) on the output side of the servo amplifier.
- Correctly connect the output side (terminal U, V, W). Incorrect connections will lead the servomotor to operate abnormally.
- Do not connect a commercial power supply to the servomotor, as this may lead to trouble.

⚠ CAUTION

- Do not mistake the direction of the surge absorbing diode installed on the DC relay for the control signal output of brake signals, etc. Incorrect installation may lead to signals not being output when trouble occurs or the protective functions not functioning.

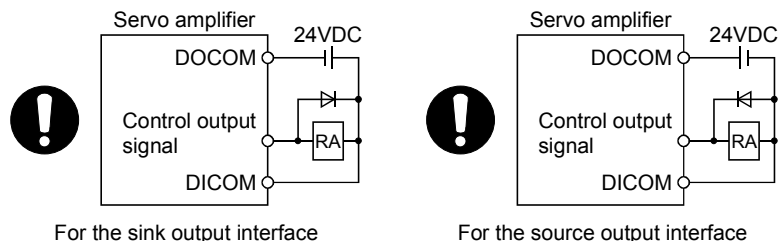

- Do not connect or disconnect the connection cables between each unit, the encoder cable or PLC expansion cable while the power is ON.
- Securely tighten the cable connector fixing screws and fixing mechanisms. Insufficient fixing may lead to the cables coming off during operation.
- Do not bundle the power line or cables.
- Use applicable solderless terminals and tighten them with the specified torque.
If any solderless spade terminal is used, it may be disconnected when the terminal screw comes loose, resulting in failure.

(5) Trial operation and adjustment

⚠ CAUTION

- Confirm and adjust the program and each parameter before operation. Unpredictable movements may occur depending on the machine.
- Extreme adjustments and changes may lead to unstable operation, so never make them.
- When using the absolute position system function, on starting up, and when the module or absolute value motor has been replaced, always perform a home position return.
- Before starting test operation, set the parameter speed limit value to the slowest value, and make sure that operation can be stopped immediately if a hazardous state occurs.

(6) Usage methods

⚠ CAUTION

- Immediately turn OFF the power if smoke, abnormal sounds or odors are emitted from the module, servo amplifier or servomotor.
- Always execute a test operation before starting actual operations after the program or parameters have been changed or after maintenance and inspection.
- Do not attempt to disassemble and repair the units excluding a qualified technician whom our company recognized.
- Do not make any modifications to the unit.
- Keep the effect or electromagnetic obstacles to a minimum by installing a noise filter or by using wire shields, etc.

Electromagnetic obstacles may affect the electronic devices used near the module or servo amplifier.

- When using the CE Mark-compliant equipment design, refer to the "EMC Installation Guidelines" (data number IB(NA)-67339) and refer to the corresponding EMC guideline information for the servo amplifiers and other equipment.
- Note that when the reference axis speed is designated for interpolation operation, the speed of the partner axis (2nd axis, 3rd axis and 4th axis) may be larger than the set speed (larger than the speed limit value).
- Use the units with the following conditions.

Item	Conditions
Input power	According to each instruction manual.
Input frequency	According to each instruction manual.
Tolerable momentary power failure	According to each instruction manual.

(7) Corrective actions for errors

⚠ CAUTION

- If an error occurs in the self diagnosis of the module or servo amplifier, confirm the check details according to the instruction manual, and restore the operation.
- If a dangerous state is predicted in case of a power failure or product failure, use a servomotor with electromagnetic brakes or install a brake mechanism externally.
- Use a double circuit construction so that the electromagnetic brake operation circuit can be operated by emergency stop signals set externally.

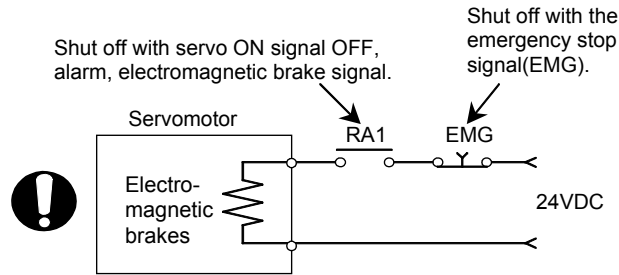

- If an error occurs, remove the cause, secure the safety and then resume operation after alarm release.
- The unit may suddenly resume operation after a power failure is restored, so do not go near the machine. (Design the machine so that personal safety can be ensured even if the machine restarts suddenly.)

(8) Maintenance, inspection and part replacement

⚠ CAUTION

- Perform the daily and periodic inspections according to the instruction manual.
- Perform maintenance and inspection after backing up the program and parameters for the module and servo amplifier.
- Do not place fingers or hands in the clearance when opening or closing any opening.
- Periodically replace consumable parts such as batteries according to the instruction manual.
- Do not touch the lead sections such as ICs or the connector contacts.
- Before touching the module, always touch grounded metal, etc. to discharge static electricity from human body. Failure to do so may cause the module to fail or malfunction.
- Do not directly touch the module's conductive parts and electronic components. Touching them could cause an operation failure or give damage to the module.
- Do not place the module or servo amplifier on metal that may cause a power leakage or wood, plastic or vinyl that may cause static electricity buildup.
- Do not perform a megger test (insulation resistance measurement) during inspection.
- When replacing the module or servo amplifier, always set the new module settings correctly.
- When the module or absolute value motor has been replaced, carry out a home position return operation using one of the following methods, otherwise position displacement could occur.
 - 1) After writing the servo data to the positioning module using programming software, switch on the power again, then perform a home position return operation.

CAUTION

- After maintenance and inspections are completed, confirm that the position detection of the absolute position detector function is correct.
- Do not drop or impact the battery installed to the module.
Doing so may damage the battery, causing battery liquid to leak in the battery. Do not use the dropped or impacted battery, but dispose of it.
- Do not short circuit, charge, overheat, incinerate or disassemble the batteries.
- The electrolytic capacitor will generate gas during a fault, so do not place your face near the module or servo amplifier.
- The electrolytic capacitor and fan will deteriorate. Periodically replace these to prevent secondary damage from faults. Replacements can be made by our sales representative.
- Lock the control panel and prevent access to those who are not certified to handle or install electric equipment.
- Do not mount/remove the module onto/from the base unit more than 50 times (IEC61131-2-compliant), after the first use of the product. Failure to do so may cause malfunction.
- Do not burn or break a module and servo amplifier. Doing so may cause a toxic gas.

(9) About processing of waste

When you discard module, servo amplifier, a battery (primary battery) and other option articles, please follow the law of each country (area).

CAUTION

- This product is not designed or manufactured to be used in equipment or systems in situations that can affect or endanger human life.
- When considering this product for operation in special applications such as machinery or systems used in passenger transportation, medical, aerospace, atomic power, electric power, or submarine repeating applications, please contact your nearest Mitsubishi sales representative.
- Although this product was manufactured under conditions of strict quality control, you are strongly advised to install safety devices to forestall serious accidents when it is used in facilities where a breakdown in the product is likely to cause a serious accident.

(10) General cautions

CAUTION

- All drawings provided in the instruction manual show the state with the covers and safety partitions removed to explain detailed sections. When operating the product, always return the covers and partitions to the designated positions, and operate according to the instruction manual.

REVISIONS

* The manual number is given on the bottom left of the back cover.

Print Date	* Manual Number	Revision
Apr., 2009	IB(NA)-0300147-A	First edition
Dec., 2011	IB(NA)-0300147-B	[Partial correction] Safety Precautions, Section 4.2.1 Partial change of sentence

Japanese Manual Number IB(NA)-0300146

This manual confers no industrial property rights or any rights of any other kind, nor does it confer any patent licenses. Mitsubishi Electric Corporation cannot be held responsible for any problems involving industrial property rights which may occur as a result of using the contents noted in this manual.

INTRODUCTION

Thank you for choosing the high-speed, multi-axis Positioning Module QD74MH.
Before using the equipment, please read this manual carefully to develop full familiarity with the functions and performance of the Positioning Module you have purchased, so as to ensure correct use.

CONTENTS

Safety Precautions	A- 1
Revisions	A-11
Contents	A-12
Using This Manual.....	A-17
Compliance with the EMC and Low Voltage Directives.....	A-17
1. OVERVIEW	1- 1 to 1-12
1.1 Overview.....	1- 1
1.2 Mechanism of Positioning Control.....	1- 4
1.3 Communicating Signals Between QD74MH and Each Module	1- 5
1.4 Difference Between QD74MH and QD75MH	1- 7
2. SYSTEM CONFIGURATION	2- 1 to 2-10
2.1 System Configuration.....	2- 1
2.2 Applicable System.....	2- 2
2.3 Component List	2- 4
2.4 Name of Parts	2- 5
2.5 Basic Specifications	2- 7
2.6 Forced Stop Input Terminal	2- 8
2.7 Checking Function Version and Serial No.	2- 9
3. DESIGN	3- 1 to 3- 8
3.1 System Designing Procedure	3- 1
3.2 External Circuit Design	3- 2
3.2.1 Power supply circuit design	3- 6
3.2.2 Safety circuit design	3- 7
4. INSTALLATION, WIRING, START-UP AND MAINTENANCE	4- 1 to 4-24
4.1 Handling Precautions.....	4- 1
4.2 Wiring.....	4- 3
4.2.1 SSCNET III cable	4- 4
4.2.2 Forced stop input cable.....	4-15
4.3 Confirming the Installation and Wiring.....	4-17
4.3.1 Items to confirm when installation and wiring are completed	4-17
4.4 Start-up.....	4-18
4.4.1 Checklist before trial operation	4-18
4.4.2 Trial operation and adjustment procedure	4-19
4.5 Maintenance.....	4-22

4.5.1 Precautions for maintenance	4-22
4.5.2 Disposal instructions	4-22
4.6 Daily Inspection	4-23
4.7 Periodic Inspection	4-24

5. SPECIFICATIONS AND FUNCTIONS	5- 1 to 5- 6
--	---------------------

5.1 Specifications of Input/Output Signals	5- 1
5.1.1 List of input/output signals	5- 1
5.1.2 Input signals (QD74MH → PLC CPU)	5- 2
5.1.3 Output signals (PLC CPU → QD74MH)	5- 3
5.2 Functions	5- 4
5.2.1 QD74MH control functions	5- 4
5.2.2 Functions of QD74MH	5- 5

6. DATA USED FOR POSITIONING CONTROL	6- 1 to 6-52
---	---------------------

6.1 Memory Configuration and Roles	6- 1
6.2 Data Transmission Process	6- 3
6.2.1 Data transmission process for operation	6- 3
6.2.2 Setting of servo amplifier series	6- 5
6.2.3 Exchange of the servo parameters	6- 6
6.3 Buffer Memory Configuration	6- 8
6.4 Parameter Data	6-24
6.4.1 Basic parameter	6-24
6.4.2 OPR parameter	6-26
6.4.3 Manual control parameter	6-27
6.4.4 System parameter	6-27
6.5 Monitor Data	6-28
6.5.1 Axis monitor data	6-28
6.5.2 System monitor data	6-35
6.6 Control Data	6-36
6.6.1 Axis control data	6-36
6.6.2 System control data	6-39
6.7 Positioning Data	6-42
6.8 Servo Parameter	6-44

7. OPR CONTROL	7- 1 to 7-18
-----------------------	---------------------

7.1 Outline of OPR Control	7- 1
7.1.1 Data used for control	7- 1
7.1.2 Starting method of OPR	7- 2
7.2 Proximity Dog Type	7- 3
7.3 Data Set Type	7- 6
7.4 Stopper Type	7- 7
7.5 Dog Cradle Type	7- 8
7.6 Limit Switch Combined Type	7-11
7.7 Scale Origin Signal Detection Type	7-12
7.8 OP Shift Function	7-14
7.8.1 Control details	7-14

7.8.2 Setting range of OP shift amount	7-15
7.9 OP Search Limit Function.....	7-16
7.9.1 Control details.....	7-16

8. POSITIONING CONTROL	8- 1 to 8-16
-------------------------------	---------------------

8.1 Outline of Positioning Controls	8- 1
8.1.1 Data required for positioning control.....	8- 1
8.1.2 Operation patterns of positioning controls.....	8- 2
8.1.3 Designating the positioning address.....	8- 5
8.2 1-axis Linear Control.....	8- 6
8.2.1 Starting method	8- 6
8.2.2 Control details.....	8- 7
8.2.3 Restrictions for 1-axis linear control.....	8- 8
8.3 Linear Interpolation Control	8- 9
8.3.1 Data used for control.....	8- 9
8.3.2 Setting of linear interpolation axis.....	8-10
8.3.3 Starting method	8-11
8.3.4 Control details.....	8-12
8.3.5 Speed/acceleration/deceleration	8-14
8.3.6 Restrictions.....	8-15

9. MANUAL CONTROL	9- 1 to 9- 6
--------------------------	---------------------

9.1 JOG Operation	9- 1
9.1.1 Control details.....	9- 2
9.1.2 Data used for control.....	9- 4
9.2 Incremental Feed Operation.....	9- 5
9.2.1 Control details.....	9- 5
9.2.2 Precautions for control	9- 6
9.2.3 Data used for control.....	9- 6

10. FUNCTION DETAILS	10- 1 to 10-46
-----------------------------	-----------------------

10.1 Servo ON/OFF	10- 1
10.1.1 Control details.....	10- 1
10.1.2 Data used for control.....	10- 2
10.1.3 Follow up function	10- 2
10.2 Electronic Gear Function	10- 3
10.2.1 Control details.....	10- 3
10.2.2 Data used for control.....	10- 6
10.3 Hardware Stroke Limit Function	10- 7
10.3.1 Control details.....	10- 7
10.3.2 Data used for control.....	10- 8
10.4 Software Stroke Limit Function.....	10- 9
10.4.1 Control details.....	10- 9
10.4.2 Restrictions at absolute position system use	10-10
10.4.3 Data used for control.....	10-11
10.5 Backlash Compensation Function.....	10-12
10.5.1 Control details.....	10-12

10.5.2 Data used for control.....	10-12
10.6 Speed Limit Function	10-13
10.6.1 Control details.....	10-13
10.6.2 Data used for control.....	10-14
10.7 Acceleration/Deceleration Control.....	10-15
10.7.1 Control details.....	10-15
10.7.2 Data used for control.....	10-16
10.8 Stop Control	10-17
10.8.1 Control details.....	10-17
10.8.2 Data used for control.....	10-17
10.9 Sudden Stop Control.....	10-18
10.9.1 Control details.....	10-18
10.9.2 Data used for control.....	10-18
10.10 Forced Stop Control.....	10-19
10.10.1 Control details	10-19
10.10.2 Data used for control.....	10-20
10.11 Command In-position Function	10-21
10.11.1 Control details	10-21
10.11.2 Data used for control.....	10-22
10.12 Pausing Function	10-23
10.12.1 Control details	10-23
10.12.2 Data used for control.....	10-24
10.13 Torque Limit Function	10-25
10.13.1 Control details	10-25
10.13.2 Data used for control.....	10-26
10.14 Speed Change Function.....	10-27
10.14.1 Control details	10-27
10.14.2 Precautions.....	10-28
10.14.3 Data used for control.....	10-28
10.15 Acceleration/Deceleration Time Change Function.....	10-29
10.15.1 Control details	10-29
10.15.2 Precautions.....	10-30
10.15.3 Data used for control.....	10-31
10.16 Target Position Change Function.....	10-32
10.16.1 Control details	10-32
10.16.2 Data used for control.....	10-34
10.17 Current Value Change Function.....	10-35
10.17.1 Control details	10-35
10.17.2 Data used for control.....	10-35
10.18 External Signal Logic Selection	10-36
10.18.1 Control details	10-36
10.18.2 Data used for control.....	10-36
10.19 Operation Setting for Incompletion of OPR Function	10-37
10.19.1 Control details	10-37
10.19.2 Data used for control.....	10-38
10.20 Axis Error Reset.....	10-39
10.20.1 Control details	10-39
10.20.2 Data used for control.....	10-39
10.21 Absolute position system.....	10-40

10.21.1 Control details	10-40
10.22 Flash ROM Write Function	10-42
10.22.1 Control details	10-42
10.22.2 Data used for control.....	10-43
10.23 Parameter Initialization Function	10-44
10.23.1 Control details	10-44
10.23.2 Data used for control.....	10-45
10.24 Parameter Change Function	10-46
10.24.1 Control details	10-46
10.24.2 Data used for control.....	10-46

11. TROUBLESHOOTING	11- 1 to 11-16
----------------------------	-----------------------

11.1 Error and Warning Details	11- 1
11.1.1 Errors	11- 1
11.1.2 Warnings	11- 3
11.1.3 Confirming the error and warning definitions	11- 3
11.1.4 Resetting errors.....	11- 3
11.2 List of Errors	11- 4

APPENDICES	App- 1 to App-50
-------------------	-------------------------

Appendix 1 External Dimension Drawing	App- 1
Appendix 2 Sample Program.....	App- 2
Appendix 2.1 Sequence program	App- 2
Appendix 2.2 Creating the program.....	App- 5
Appendix 2.3 Debugging.....	App-10
Appendix 2.4 Positioning program example.....	App-11
Appendix 3 List of Buffer Memory Address.....	App-18
Appendix 3.1 Parameter area	App-18
Appendix 3.2 Monitor data area.....	App-20
Appendix 3.3 Control data area	App-22
Appendix 3.4 Positioning data area.....	App-24
Appendix 3.5 Servo parameter area.....	App-38

Using This Manual

- The symbols used in this manual are shown below.

Pr. *	Symbol indicating positioning parameter item.
Da. *	Symbol indicating positioning data item.
Md. *	Symbol indicating monitor data item.
Cd. *	Symbol indicating control data item.

(A serial No. is inserted in the * mark.)

- Representation of numerical values used in this manual.

- Buffer memory addresses, error codes and warning codes are represented in decimal.
- X/Y devices are represented in hexadecimal.
- Setting data and monitor data are represented in decimal or hexadecimal. Data ended by "H" or "h" are represented in hexadecimal.

(Example) 10 Decimal
 10h Hexadecimal

Compliance with the EMC and Low Voltage Directives

- (1) For programmable controller system

To configure a system meeting the requirements of the EMC and Low Voltage Directives when incorporating the Mitsubishi programmable controller (EMC and Low Voltage Directives compliant) into other machinery or equipment, refer to Chapter 9 "EMC AND LOW VOLTAGE DIREVTIVES" of the QCPU User's Manual (Hardware Design, Maintenance and Inspection). The CE mark, indicating compliance with the EMC and LOW Voltage Directives, is printed on the rating plate of the programmable controller.

- (2) For programmable controller system

For the compliance of this product with the EMC and Low Voltage Directives, refer to Section 4.2 "Wiring" of the chapter 4. And, refer to the EMC Installation Guidelines (IB(NA)67339) for the servo amplifiers or servo motors.

Generic Terms and Abbreviations

Unless specially noted, the following generic terms and abbreviations are used in this manual.

Generic term/abbreviation	Details of generic term/abbreviation
PLC CPU	Generic term for PLC CPU on which QD74MH can be mounted.
QD74MH	Generic term for positioning module QD74MH8 and QD74MH16. The module type is described to indicate a specific module.
MR-J3-B	Servo amplifier: Abbreviation for MR-J3-□B. (□ = capacity)
Peripheral device	Generic term for DOS/V personal computer that can run the following "GX Developer".
GX Developer	Abbreviation for GX Developer (SW4D5C-GPPW-E or later)
Servo amplifier	Abbreviation for SSCNETⅢ compatible servo amplifier.
DOS/V personal computer	IBM PC/AT [®] and compatible DOS/V compliant personal computer. (Including PC98-NX [®])
PC-9800 [®]	Abbreviation for PC-9800 [®] series. (Excluding PC98-NX [®])
Personal computer	Generic term for DOS/V personal computer.
Workpiece	Generic term for moving body such as workpiece and tool, and for various control targets.
Axis 1, Axis 2 ... Axis 16	Indicates each axis connected to QD74MH.
1-axis, 2-axis ... 16-axis	Indicates the number of axes. (Example: 2-axis = Indicates two axes such as axis 1 and axis 2, axis 2 and axis 3, and axis 3 and axis 1.)
OPR	Abbreviation for "Home position return"
OP	Abbreviation for "Home position"
SSCNETⅢ (Note)	High speed synchronous communication network between QD74MH and servo amplifier.

(Note): SSCNET: Servo System Controller NETwork

Component List

The table below shows the component included in respective positioning modules:

Module name	Quantity	
	QD74MH8	QD74MH16
QD74MH8 positioning module	1	
QD74MH16 positioning module		1
Before Using the Product		1

1. OVERVIEW

This User's Manual describes the hardware specifications and handling methods of the Q series high-speed, multi-axis Positioning Module QD74MH8/QD74MH16 (herein after referred to as QD74MH).

1.1 Overview

QD74MH Positioning module is used in the multiple axes without complex controls.

(1) Availability of eight and sixteen axes modules

- (a) Eight and sixteen axes positioning modules are available.
They can be selected according to the number of required control axes.
(Refer to Section 2.3.)
- (b) For connecting any of the QD74MH modules to the base unit, a single slot and 32 dedicated I/O channels are required.
Within the limit imposed by the maximum number of inputs and outputs supported by the PLC CPU, up to 64 modules can be used.
(Refer to Section 2.2.)

(2) Operation Cycle

- (a) Operation cycle is 0.88[ms].

(3) Easy positioning control functions

- (a) Positioning control functions essential to any positioning system are supported: positioning to an arbitrary position, incremental feed control, continuous-locus control, and so on. (Refer to Chapter 8 or Section 9.2.)
 - 1) Up to 32 positioning data items, including such information as "[Da.6] Positioning address/movement amount", "[Da.1] Control systems", and "[Da.0] Operation pattern", can be prepared for each axis.
Using the prepared positioning data, the positioning control is performed independently for each axis. (In addition, interpolation control is possible.)
 - 2) Independent control of each axis can be achieved in linear control mode.
Such control can either be the independent positioning control using a single positioning data or the continuous positioning control enabled by the continuous processing of multiple positioning data.
 - 3) Coordinated control over multiple axes can take the linear interpolation through the position control.
Such control can either be the independent positioning control using a single positioning data or the continuous positioning control enabled by the continuous processing of multiple positioning data.
- (b) Continuous positioning control using multiple positioning data can be executed in accordance with the operation patterns the user assigned to the positioning data. (Refer to Section 6.7 and 8.1.2.)

- (c) OPR control is given additional features (Refer to Chapter 7.)
Six different OPR methods are provided: the proximity dog type, data set type, stopper type, dog cradle type, limit switch combined type, and the scale origin signal detection type.
 - (d) Two acceleration/deceleration control methods are provided: Linear acceleration/deceleration and S-curve acceleration/deceleration.
(Refer to Section 10.7.)
- (4) Quick startup
A positioning operation starts up quickly taking as little as 0.88[ms].
- (5) SSCNET III makes the connection to the servo amplifier possible
- (a) The QD74MH can be directly connected to the Mitsubishi servo amplifier MR-J3-B using the SSCNET III.
 - (b) Because the SSCNET III cable is used to connect the QD74MH and the servo amplifier, or servo amplifiers, saving wiring can be realized. The maximum distance between the QD74MH and servo amplifier, servo amplifier and servo amplifier of the SSCNET III cable on the same bus was set to 50(164.04[m(ft.)]), and the flexibility improved at the system design.
 - (c) The servo parameters can be set on the QD74MH side to write or read them to/from the servo amplifier using the SSCNET III.
 - (d) The actual current value and error description contained in the servo can be checked by the buffer memory of the QD74MH.
 - (e) Wiring is reduced by issuing the external signal (upper/lower stroke limit signal, proximity dog signal) via the servo amplifier.
- (6) Easy application to the absolute position system
- (a) The absolute position-corresponding servo motor and servo amplifier are used to have an application to the absolute position system.
 - (b) Once the OP have been established, the OPR operation is unnecessary when the power is supplied.
 - (c) With the absolute position system, the data set method OPR is used to establish the OP.
- (7) Easy maintenance
Each QD74MH positioning module incorporates the following improvements in maintainability:
- (a) Data such as the positioning data and parameters can be stored on a flash ROM inside the QD74MH, eliminating the need of a battery for retaining data. (Refer to Section 6.1.)
 - (b) Error messages are classified in more detail to facilitate the initial troubleshooting procedure. (Refer to Section 11.1.)

(8) Addition of forced stop function

As forced stop input signal to the connector for external equipment connection is added, batch forced stop is available for all axes of servo amplifier.

(Refer to Section 10.10.)

Selection for "Valid/Invalid" of the forced stop input signal by external 24VDC can be made with parameter.

1.2 Mechanism of Positioning Control

In the positioning system using the QD74MH, software and devices are used for the following roles. The QD74MH realizes complicated positioning control when it reads in various signals, parameters and data and is controlled with the PLC CPU.

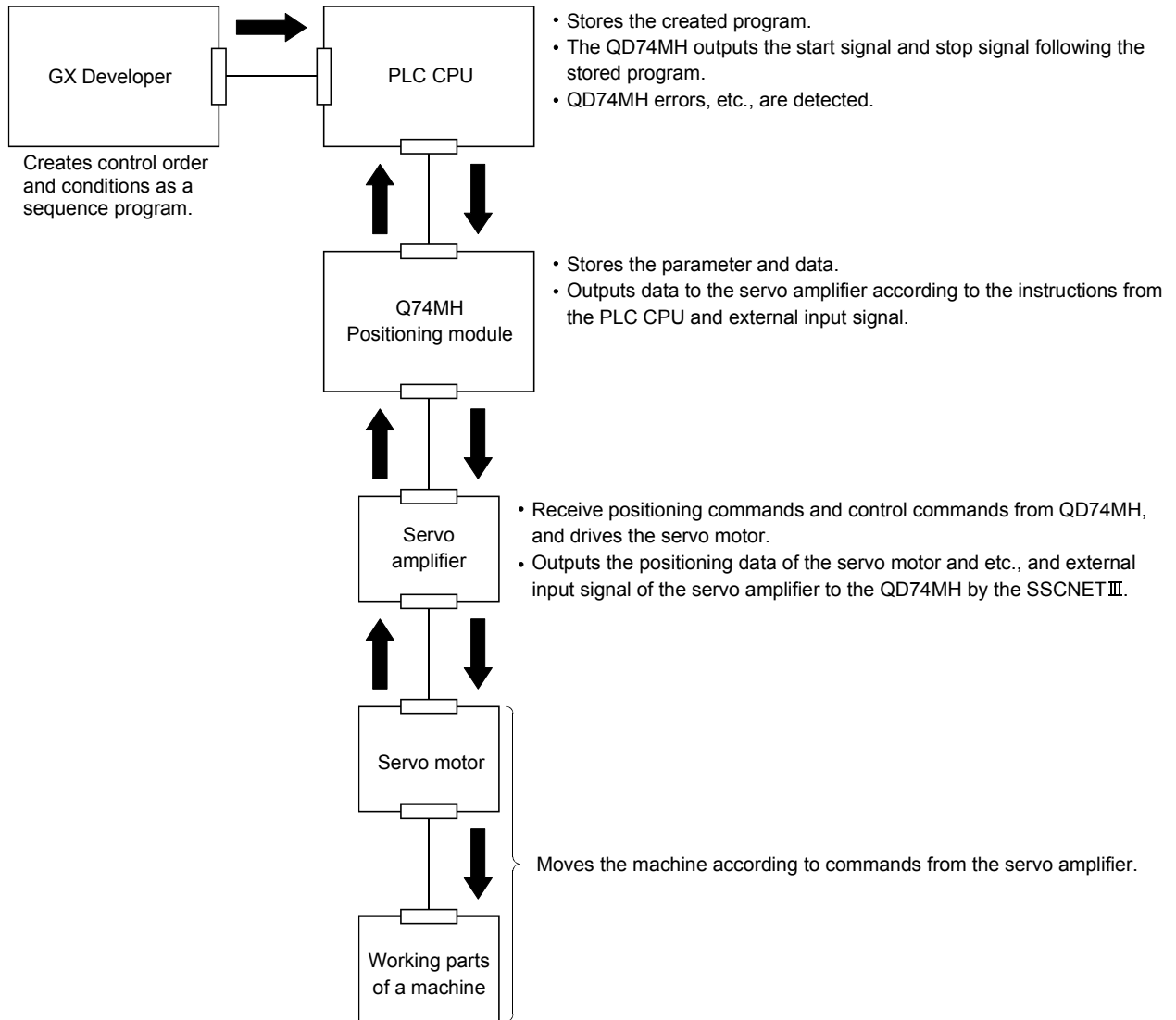

1.3 Communicating Signals Between QD74MH and Each Module

The outline of the signal communication between the QD74MH (positioning module) and PLC CPU, peripheral device and servo amplifier, etc., is shown below.

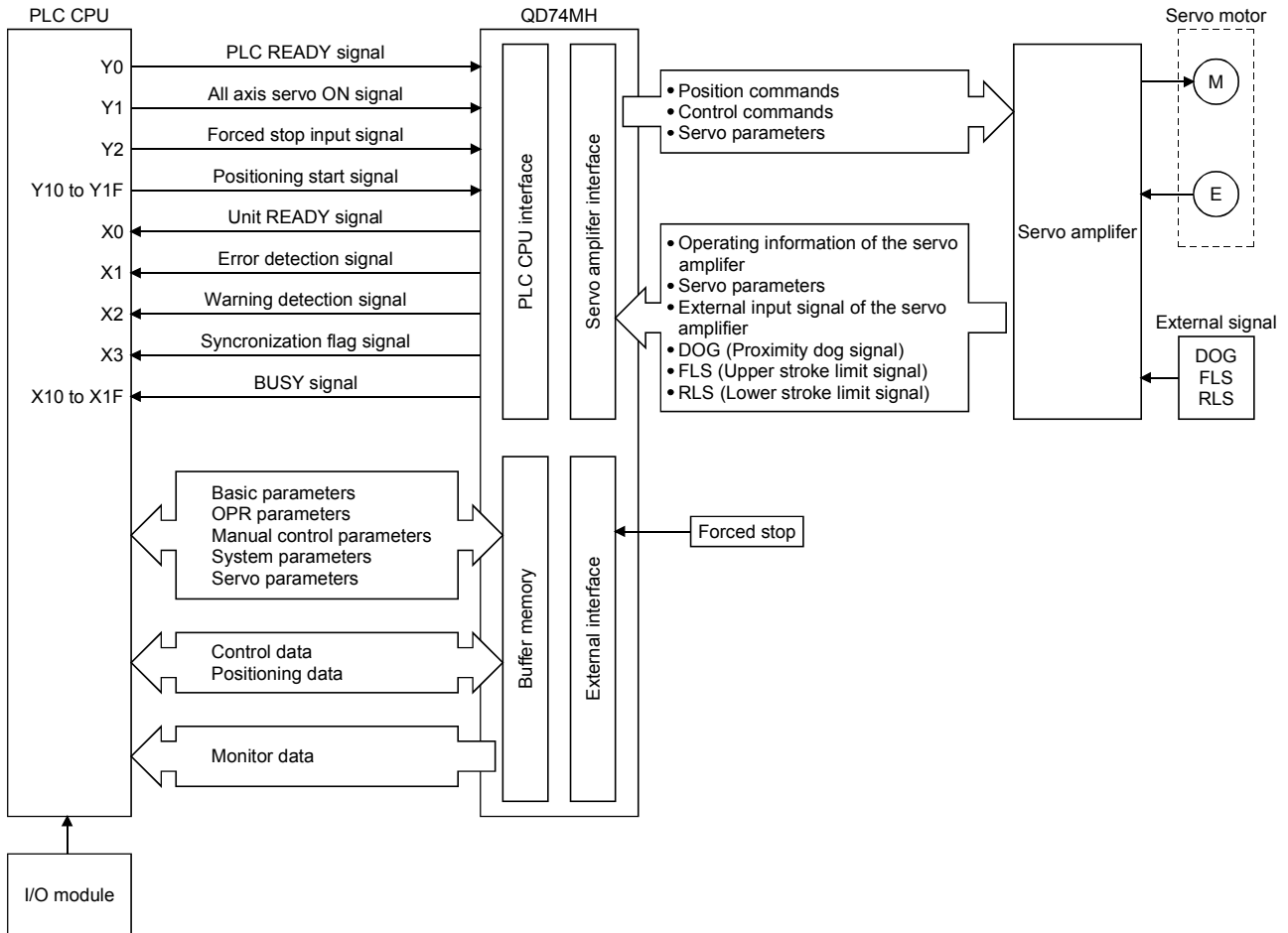

(1) QD74MH — PLC CPU

The QD74MH and PLC CPU communicate the following data via the base unit.

Communication	Details	Signal direction
Control signals	Signal related to commands <ul style="list-style-type: none"> • Y0: PLC READY signal • Y1: All axis servo ON signals • Y2: Stop signals • Y10 to Y1F: Positioning start signals 	PLC CPU → QD74MH
Write data	Data to be written to buffer memory <ul style="list-style-type: none"> • Parameter (Basic, OPR, Manual control, System, Servo) • Control data • Positioning data 	
Status signal	Signal indicating QD74MH state <ul style="list-style-type: none"> • X0: Unit READY signal • X1: Error detection signal • X2: Warning detection signal • X2: Synchronization flag signal • X10 to X1F: Busy signal 	QD74MH → PLC CPU
Read data	Data to be read from buffer memory <ul style="list-style-type: none"> • Parameters (Basic, OPR, Manual control, System, Servo) • Monitor data • Control data • Positioning data 	

(2) QD74MH — Servo amplifier

The QD74MH and servo amplifier communicate the following data via the SSCNET III.

Communication	Details	Signal direction
Control signals of SSCNET III	Command signals to servo amplifier <ul style="list-style-type: none"> • Position commands • Control commands • Servo parameters 	QD74MH → Servo amplifier
Status signals of SSCNET III	Monitor information of the servo amplifier <ul style="list-style-type: none"> • Operating information of the servo amplifier • Servo parameters (Auto tuning, Parameter change by MR Configurator, etc.) • External input signals (DOG, FLS, RLS) of the servo amplifier 	Servo amplifier → QD74MH

(3) QD74MH — Forced stop input signal

The QD74MH and forced stop input signal communicate the following data via the forced stop input connector.

Communication	Details	Signal direction
Forced stop input signal	Forced stop input signal to QD74MH	Forced stop input → QD74MH

1.4 Difference Between QD74MH and QD75MH

(1) Comparisons of performance specifications

Item		Model	QD74MH	QD75MH
Number of control axes			8 axes/16 axes	1 axis/2 axes/4 axes
Operation cycle			0.88ms	1.77ms
Control unit			PLS	mm, inch, degree, PLS
Number of positioning data			32/axis	600/axis
Interpolation functions			Linear interpolation (2, 3, 4 axes)	Linear interpolation (2, 3, 4 axes), Circular interpolation (2 axes)
			Speed: Combined-speed, Interpolation group: Up to 4 groups	Speed: Vector speed and reference axis
Positioning control	Operation pattern	Independent positioning	○	○
		Continuous positioning	○	○
		Continuous path	○	○
	Speed control	×	○	
	Speed-position switching	×	○	
	Position-speed switching	×	○	
Positioning range			<ABS/INC system> -2147483648 to 2147483647 [PLS] <u>Note</u> Positioning that exceeds the positioning range cannot be executed.	<ABS/INC system> -214748364.8 to 214748364.7 [μ m] -21474.83648 to 21474.83647 [inch] 0 to 359.99999[degree] -2147483648 to 2147483647 [PLS] -21474.83648 to 21474.83647 [degree] (Fixed-pitch feed only)
Speed command range			5 to 2147000000[PLS/s]	0.01 to 20000000.00[mm/min] 0.001 to 2000000.000[inch/min] 0.001 to 2000000.000[degree/min] 1 to 10000000[PLS/s]
OPR control	OPR method		Proximity dog type, Data set type, Stopper type, Dog cradle type, Limit switch combined type, Scale origin signal detection type	Proximity dog type, Count type 1, Count type 2, Data set type
	OP shift function		○ -2147483648 to 2147483647	○ -2147483648 to 2147483647
	Retry function		○	○
	OP search limit function		○	×

Performance specifications (continued)

Items		Type	QD74MH	QD75MH
Manual control	JOG		○	○
	Incremental feed ^(Note-1)		○ (Acceleration/deceleration: Provided)	○ (Acceleration/deceleration: None)
	Manual pulse generator input		×	○
External signal input (Upper/lower stroke limit, Near-dog)			Via servo amplifier	Direct input, Via servo amplifier
Forced stop input			24VDC input, Via PLC CPU, Invalid setting enable	24VDC input, Invalid setting enable
Data save			Flash ROM	Flash ROM
Positioning module setting/monitor tool			×	GX Configurator-QP
Number of I/O points			32 points	32 points
Number of occupied slots			1	1

○: Provided ×: N/A

(Note-1): Inching operation for QD75MH

(2) Comparisons of input/output signals with PLC CPU specifications

Model Item	QD74MH		QD75MH			
X0	Unit READY		QD75 READY			
X1	Error detection		Synchronization flag			
X2	Warning detection		Unusable			
X3	Synchronization flag					
X4	Unusable		Axis 1	M code ON		
X5			Axis 2			
X6			Axis 3			
X7			Axis 4			
X8			Axis 1	Error detection		
X9			Axis 2			
XA			Axis 3			
XB			Axis 4			
XC			Axis 1	BUSY		
XD			Axis 2			
XE			Axis 3			
XF			Axis 4			
X10			Axis 1	BUSY	Axis 1	Start complete
X11			Axis 2		Axis 2	
X12			Axis 3		Axis 3	
X13			Axis 4		Axis 4	
X14	Axis 5	Axis 1	Positioning complete			
X15	Axis 6	Axis 2				
X16	Axis 7	Axis 3				
X17	Axis 8	Axis 4				
X18	Axis 9	Unusable				
X19	Axis 10					
X1A	Axis 11					
X1B	Axis 12					
X1C	Axis 13					
X1D	Axis 14					
X1E	Axis 15					
X1F	Axis 16					

Model	QD74MH		QD75MH			
Item						
Y0	PLC READY		PLC READY			
Y1	All axis servo ON		All axis servo ON			
Y2	Forced stop input		Unusable			
Y3	Unusable		Axis 1	Axis stop		
Y4			Axis 2			
Y5			Axis 3			
Y6			Axis 4			
Y7					Axis 1	Forward run JOG start
Y8					Axis 1	Reverse run JOG start
Y9					Axis 2	Forward run JOG start
YA					Axis 2	Reverse run JOG start
YB					Axis 3	Forward run JOG start
YC					Axis 3	Reverse run JOG start
YD					Axis 4	Forward run JOG start
YE					Axis 4	Reverse run JOG start
YF						
Y10			Axis 1	Positioning start	Axis 1	Positioning start
Y11	Axis 2	Axis 2				
Y12	Axis 3	Axis 3				
Y13	Axis 4	Axis 4				
Y14	Axis 5	Axis 1	Execution prohibition flag			
Y15	Axis 6	Axis 2				
Y16	Axis 7	Axis 3				
Y17	Axis 8	Axis 4				
Y18	Axis 9	Unusable				
Y19	Axis 10					
Y1A	Axis 11					
Y1B	Axis 12					
Y1C	Axis 13					
Y1D	Axis 14					
Y1E	Axis 15					
Y1F	Axis 16					

(3) Comparisons of functions

Item		Model	QD74MH	QD75MH
Communication start timing with the servo amplifiers			PLC READY ON (First time only)	Control power supply ON of the servo amplifier
Servo ON/OFF			○	○
Electronic gear			Denominator: 32768, Numerator: 32768	Denominator: 200000000, Numerator: For setting units
Hardware stroke limit function			○ (Via servo amplifier only)	○
Software stroke limit function			○	○
Backlash compensation function			○ 0 to 65535[PLS] (Set encoder pulse unit)	○ 0 to 65535 (Set in the unit system)
Speed limit function			○ 1000000 to 2147000000[PLS/s] (In speed control flag: None)	○ For command units
Acceleration/ deceleration control	Acceleration/ deceleration processing		Liner acceleration/deceleration, S-curve acceleration/deceleration	Trapezoidal acceleration/deceleration, S-curve acceleration/deceleration
	Acceleration/ deceleration time		20000[ms]	8388608[ms]
Stop control			○	○
Sudden-stop control			○	×
Forced stop control			○	○
Command in-position control function			○ (Only last positioning point: ON)	○ (Continuous positioning: ON)
Pausing function			○	○ (Restart function)
Torque limit function			○ 0.1[%] unit	○ 1[%] unit
Speed change function			○ 5 to 2147000000[PLS/s]	○ For command units
Acceleration/deceleration change			○ 0 to 20000[ms]	○ 0 to 8388608[ms]
Target position change function			○	○
Current value change function			○	○
External signal selection function			×	○
External signal selection logic function			○	○
Operation setting for incompleteness of OPR function			○	○
Axis error reset			○	○
Absolute position system			○	○
Flash ROM write function			○	○
Parameter initialization function			○	○
Gain changing			○	○
History			×	Start history (16 data), Error history (16 data), Warning history (16 data)
M code output function			×	○

○: Provided ×: N/A

(4) Comparisons of major monitor data

Model			
Item		QD74MH	QD75MH
Current feed value (before electronic gear)		○	○
Machine feed value		×	○
Feedrate (before electronic gear)		○	○
Positioning data No. being executed		○	○
Last executed positioning data No.		×	○
Status	OPR request	○	○
	OPR complete	○	○
	Positioning complete	○	○
	Command in-position	○	○
Deceleration start		×	○
Movement amount after proximity dog ON		×	○
External I/O signal		○	○
Real current value (before electronic gear)		○	○
Servo status	Servo READY ON	○	○
	In-position	○	○
	Zero speed	○	○
	Zero point pass	○	○
	Torque limit	○	○
	Servo alarm	○	○
	Servo warning	○	○
	Absolute position lost	○	○
Servo amplifier software number		×	○

○: Provided ×: N/A

2. SYSTEM CONFIGURATION

This section describes the system configuration and configured equipments.

2.1 System Configuration

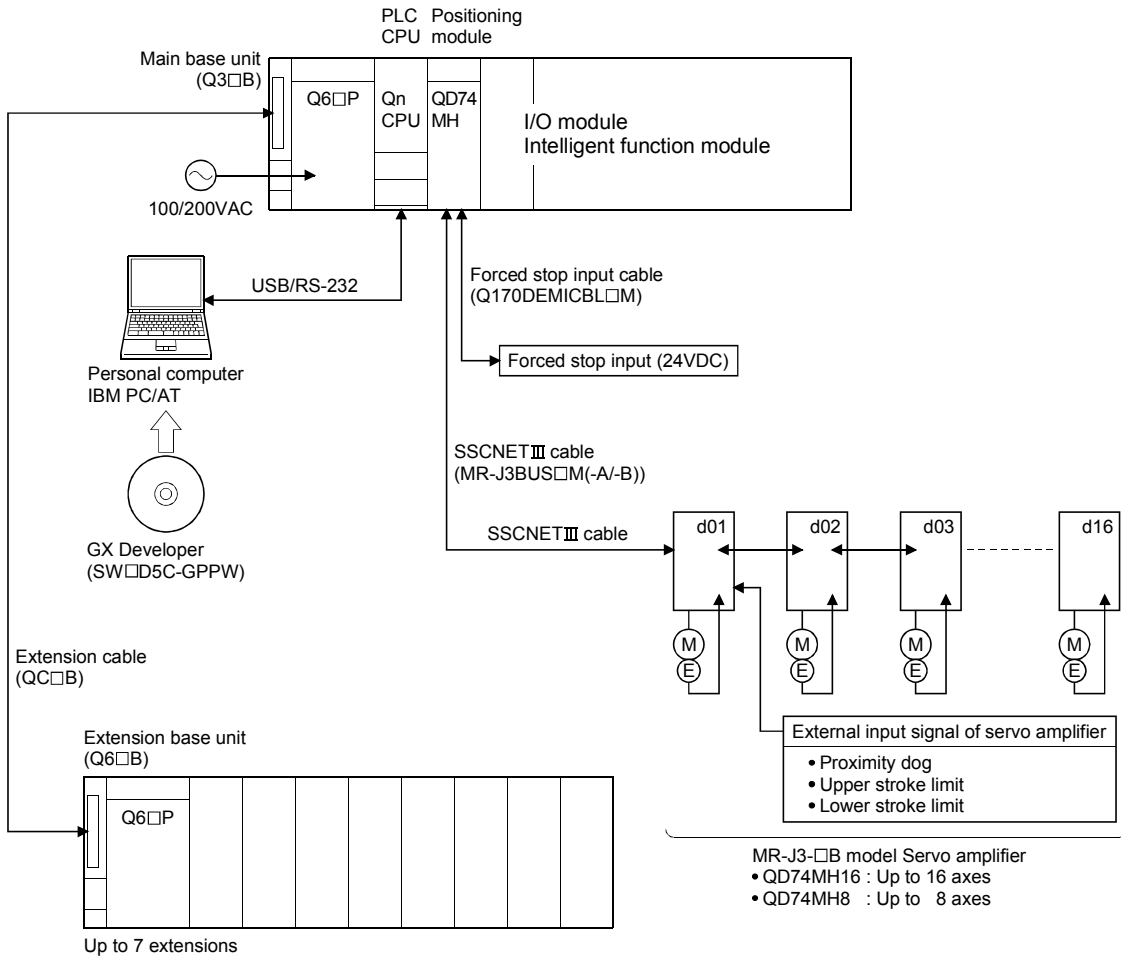

2.2 Applicable System

The QD74MH can be used in the following system.

(1) Applicable modules and base units

The table below shows the CPU modules and base units applicable to the QD74MH and quantities for each CPU module.

However, the power capacity may be insufficient depending on the combination with the other installed modules and the number of installed modules.

Be sure to check the power capacity when installing the modules.

(a) Installing to a CPU module

Usable CPU modules		Number of installable modules ^(Note-1)	Usable base units ^(Note-2)		
CPU type	CPU module		Main base unit	Extension base unit	
PLC CPU	Basic model QCPU	Q00JCPU	Up to 8		
		Q00CPU	Up to 24	○	○
		Q01CPU			
	High Performance model QCPU	Q02CPU	Up to 64	○	○
		Q02HCPU			
		Q06HCPU			
		Q12HCPU			
		Q25HCPU			
	Process CPU	Q02PHCPU	Up to 64	○	○
		Q06PHCPU			
		Q12PHCPU			
		Q25PHCPU			
	Redundant CPU	Q12PRHCPU	Up to 53	×	○
		Q25PRHCPU			
	Universal model QCPU	Q02UCPU	Up to 36	○	○
		Q03UDCPU	Up to 64		
		Q04UDHCPU			
		Q06UDHCPU			
		Q13UDHCPU			
Q26UDHCPU					
Q03UDECPU					
Q04UDEHCPU					
Q06UDEHCPU					
Q13UDEHCPU					
Q26UDEHCPU					
C Controller module	Q06CCPU-V-H01	Up to 64		○	○
	Q06CCPU-V				
	Q06CCPU-V-B				

○ : Applicable, × : Not applicable

(Note-1): Limited within the range of I/O points for the CPU module.

(Note-2): Can be installed to any I/O slot of a base unit.

(b) Installing to a MELSECNET/H remote I/O station

Usable network module	Number of installable modules ^(Note-1)	Usable base unit ^(Note-2)	
		Main base unit of remote I/O station	Extension base unit of remote I/O station
QJ72LP25-25	Up to 64	○	○
QJ72LP25G			
QJ72BR15			

○ : Applicable, × : Not applicable

(Note-1): Limited within the range of I/O points for the network module.

(Note-2): Can be installed to any I/O slot of a base unit.

REMARK

The basic model QCPU and C Controller module cannot configure the MELSECNET/H remote I/O network system.

(2) Support of the Multiple CPU system

When using the QD74MH in a Multiple CPU system, refer to the QCPU User's Manual (Multiple CPU system).

(3) Supported software packages

GX Developer is required for use of the QD74MH.

The compatibility between the systems using the QD74MH and the software packages is shown below.

		Software version
		GX Developer
Q00JCPU/Q00CPU/Q01CPU	Single PLC system	Version 7 or later
	Multiple PLC system	Version 8 or later
Q02CPU/Q02HCPU/Q06HCPU/ Q12HCPU/Q25HCPU	Single PLC system	Version 4 or later
	Multiple PLC system	Version 6 or later
Q02PHCPU/Q06PHCPU	Single PLC system	Version 8.68W or later
	Multiple PLC system	
Q12PHCPU/Q25PHCPU	Single PLC system	Version 7.10L or later
	Multiple PLC system	
Q02UCPU/Q03UDCPU/Q04UDHCPU/ Q06UDHCPU	Single PLC system	Version 8.48A or later
	Multiple PLC system	
Q13UDHCPU/Q26UDHCPU	Single PLC system	Version 8.62Q or later
	Multiple PLC system	
Q03UDECPU/Q04UDEHCPU/Q06UDEHCPU/ Q13UDEHCPU/Q26UDEHCPU	Single PLC system	Version 8.68W or later
	Multiple PLC system	
For use on MELSECNET/H remote I/O station		Version 6 or later

2.3 Component List

Product	Type	Remarks
Positioning module	QD74MH8	Up to 8 axes, SSCNETⅢ compatible
	QD74MH16	Up to 16 axes, SSCNETⅢ compatible
GX Developer	SW□D5C-GPPW	Refer to the GX Developer operating manual.
Personal computer	—	User-prepared
RS-232 cable	QC30R2	PLC CPU ↔ Personal computer
USB cable	—	PLC CPU ↔ Personal computer User-prepared
Servo amplifier	MR-J3-□B	Refer to the servo amplifier instruction manual.
	MR-J3-□B-RJ004	
	MR-J3-□B-RJ006	
SSCNETⅢ cable (Note-1)	MR-J3BUS□M	<ul style="list-style-type: none"> • QD74MH ↔ MR-J3-□B • MR-J3-□B ↔ MR-J3-□B • Standard cord for inside panel • 0.15m(0.49ft.), 0.3m(0.98ft.), 0.5m(1.64ft.), 1m(3.28ft.), 3m(9.84ft.)
	MR-J3BUS□M-A	<ul style="list-style-type: none"> • QD74MH ↔ MR-J3-□B • MR-J3-□B ↔ MR-J3-□B • Standard cable for inside panel • 5m(16.40ft.), 10m(32.81ft.), 20m(65.62ft.)
	MR-J3BUS□M-B (Note-2)	<ul style="list-style-type: none"> • QD74MH ↔ MR-J3-□B • MR-J3-□B ↔ MR-J3-□B • Long distance cable • 30m(98.43ft.), 40m(131.23ft.), 50m(164.04ft.)
Forced stop input cable (Note-1)	Q170DEMICBL□M	0.5m(1.64ft), 1m(3.28ft), 3m(9.84ft), 5m(16.40ft), 10m(32.80ft), 15m(49.20ft), 20m(65.62ft), 25m(82.02ft), 30m(98.43ft)
Connector for forced stop input cable	Q170DEMICON	Connector for forced stop input cable production

(Note-1) : □=Cable length (015: 0.15m(0.49ft.), 03: 0.3m(0.98ft.), 05: 0.5m(1.64ft.), 1: 1m(3.28ft.), 3: 3m(9.84ft.), 5: 5m(16.40ft.), 10: 10m(32.81ft.), 20: 20m(65.62ft.), 25: 25m(82.02ft.), 30: 30m(98.43ft.), 40: 40m(131.23ft.), 50:50m(164.04ft.)

(Note-2) : Please contact your nearest Mitsubishi sales representative for the cable of less than 30m(98.43ft.).

2.4 Name of Parts

This section explains the names and LED display of the QD74MH.

(1) Name of parts

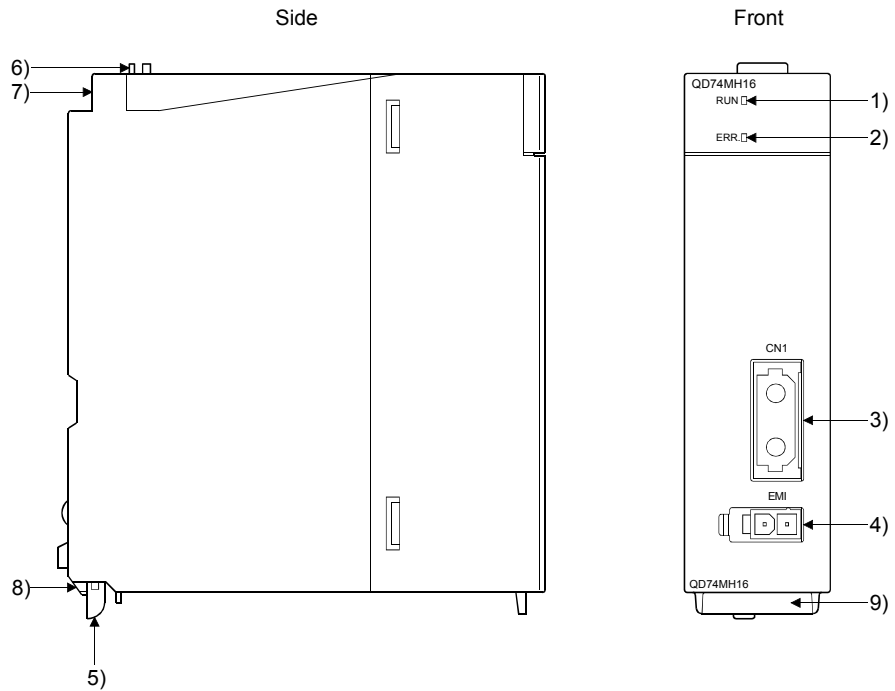

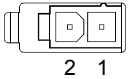
No.	Name	Application						
1)	RUN indicator LED (green)	<ul style="list-style-type: none"> • Lit: Power supply ON • Not lit: Power supply OFF 						
2)	ERR indicator LED (red (error))	<ul style="list-style-type: none"> • Lit/Flashing: Error occurrence • Not lit: Normal operation 						
3)	SSCNETⅢ cable connector (CN1) (Note-1)	Connector to connect the servo amplifier.						
4)	Forced stop input connector (EMI) 	<ul style="list-style-type: none"> • Input connector to stop all axes of servo amplifier in a lump. EMI ON (opened) : Forced stop EMI OFF (24VDC input) : Forced stop release (Note): It can be invalidated by the software setting. <table border="1" style="margin-left: auto; margin-right: auto;"> <thead> <tr> <th>Pin No.</th> <th>Signal name</th> </tr> </thead> <tbody> <tr> <td>1</td> <td>EMI</td> </tr> <tr> <td>2</td> <td>EMI.COM (Note-2)</td> </tr> </tbody> </table>	Pin No.	Signal name	1	EMI	2	EMI.COM (Note-2)
Pin No.	Signal name							
1	EMI							
2	EMI.COM (Note-2)							
5)	Module loading lever	Used to install the module to the base unit.						
6)	Module fixing hook	Hook used to fix the module to the base unit. (Auxiliary use for installation)						
7)	Module fixing screw hole	Used to fix the module to the base unit. (M3×12 screw: user-prepared)						
8)	Module fixing latch	Hook used to fix to the base unit.						
9)	Serial number plate	Indicates the serial number written on the rating plate.						

(Note-1) : Put the SSCNETⅢ cable in the duct or fix the cable at the closest part to the QD74MH with bundle material in order to prevent SSCNET cable from putting its own weight on SSCNETⅢ connector.

(Note-2) : As for the connection to common (EMI.COM), both “+” and “-” are possible.

(2) LED display

The LED displays by the state of the QD74MH as follows.

LED display		Details	Description
RUN <input type="checkbox"/>	RUN LED (green) is OFF.	Hardware failure, System error (Error code 100)	If RUN LED (green) is OFF, exchange the unit because it might be a failure.
ERR. <input type="checkbox"/>	ERR. LED (red) is OFF.		
RUN <input checked="" type="checkbox"/>	Steady RUN (green) LED display.	The module operates normally.	—
ERR. <input type="checkbox"/>	ERR. LED (red) is OFF.		
RUN <input checked="" type="checkbox"/>	Steady RUN LED (green) display.	System error (Except error code 100), Hardware failure	Check the error in the buffer memory and dispose. Exchange the unit for hardware failure because it might be a failure.
ERR. <input checked="" type="checkbox"/>	Steady ERR. LED (red) display.		
RUN <input checked="" type="checkbox"/>	Steady RUN LED (green) display.	Operation error, Interface error, Servo error	Check the error in the buffer memory and correct the parameter or positioning data.
ERR. <input checked="" type="checkbox"/>	ERR. LED (red) remains flashing.		

: OFF, : ON, : Flashing

2.5 Basic Specifications

(1) Module specifications

Item	QD74MH8	QD74MH16
Internal current consumption (5VDC) [A]	0.70	
Mass [kg]	0.15	
Exterior dimensions [mm(inch)]	98 (3.85)(H) × 27.4 (1.08)(W) × 90 (3.54)(D)	

(2) Positioning control specifications

Model		QD74MH8	QD74MH16
Item			
Number of control axes		Up to 8 axes	Up to 16 axes
Interpolation functions		2 to 4 axes linear interpolation (Up to 4 groups)	
Control methods		PTP (Point to Point) control, Locus control (Linear only)	
Control units		PLS	
Positioning data		32 data (Positioning data No.1 to 32)/axis (by sequence program)	
Back-up		Basic parameters, OPR parameters, Manual control parameters, System parameters, Servo parameters and Positioning parameters can be saved in the flash ROM. (Battery less)	
Positioning	Positioning methods	PTP control: Incremental method/Absolute method Locus control: Incremental method/Absolute method	
	Positioning range	Absolute method: -2147483648 to 2147483647 [PLS] Incremental method: -2147483648 to 2147483647 [PLS] (Note): Positioning that exceeds the positioning range is impossible.	
	Speed command range	5 to 2147000000 [PLS/s]	
	Acceleration/deceleration processing	Linear acceleration/deceleration, S-curve acceleration/deceleration	
	Acceleration/deceleration time	0 to 20000 [ms]	
	Sudden stop deceleration time	0 to 20000 [ms]	
Start time	1 axis linear control	0.88 [ms]	
	2 axes linear interpolation control		
	3 axes linear interpolation control		
	4 axes linear interpolation control		
Number of SSCNETⅢ systems		1 system	
Number of write accesses to flash ROM		Up to 100000	
Number of occupied I/O points		32 points (I/O allocation: Intelligent function module 32 points)	

REMARK

Refer to the QCPU User's Manual (Hardware Design, Maintenance and Inspection) for the general specifications.

2.6 Forced Stop Input Terminal

Item		Specifications
Number of input points		Forced stop signal : 1 point
Input method		Sink/Source type
Rated input current		3.5mA
Isolation method		Photocoupler
Operating voltage range		19.2 to 26.4VDC (+10/ -20%, ripple ratio 5% or less)
ON voltage/current		17.5VDC or more/3.0mA or more
OFF voltage/current		7VDC or less/1.0mA or less
Input resistance		Approx. 6.8k Ω
Response time	OFF to ON	4ms or less
	ON to OFF	
External connector type		2 pin connector
Applicable wire size		0.3mm ² (AWG22)

2.7 Checking Function Version and Serial No.

The function version and serial No. can be checked at the front of the QD74MH or the rating plate, and on the system monitor screen in GX Developer.

(1) Checking function version and serial No. at the QD74MH

(a) Front of QD74MH

The function version and serial No. is printed in the projection parts forward of the lower side of QD74MH.

(b) Rating plate

The rating plate is situated on the side face of the QD74MH.

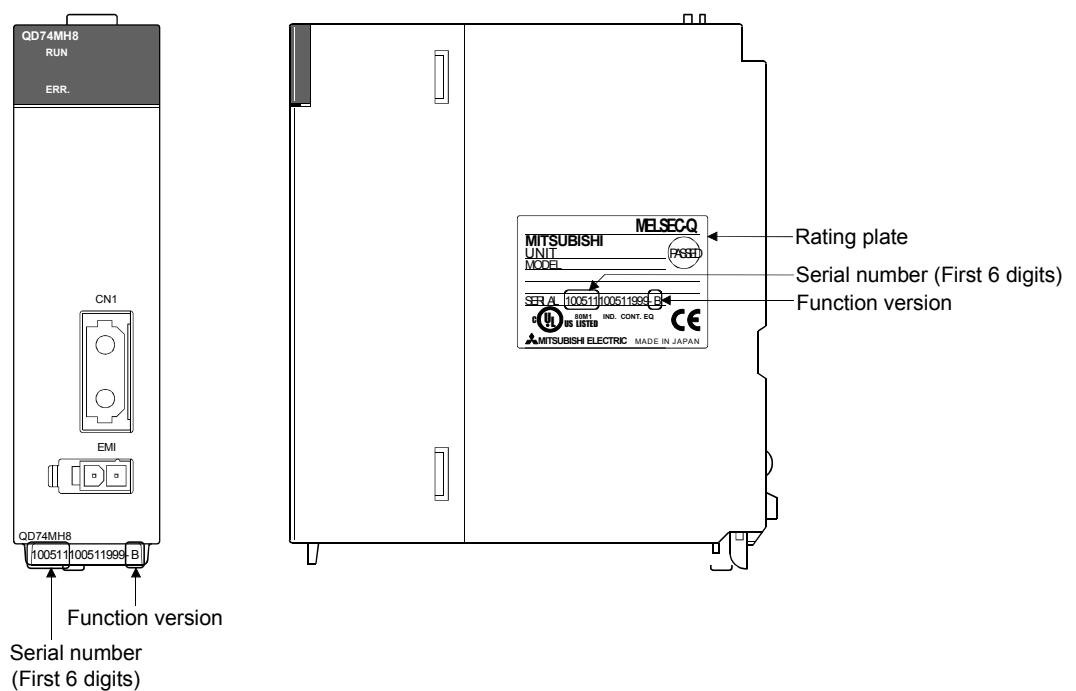

3. DESIGN

3.1 System Designing Procedure

Design the system which uses the QD74MH in the following procedure.

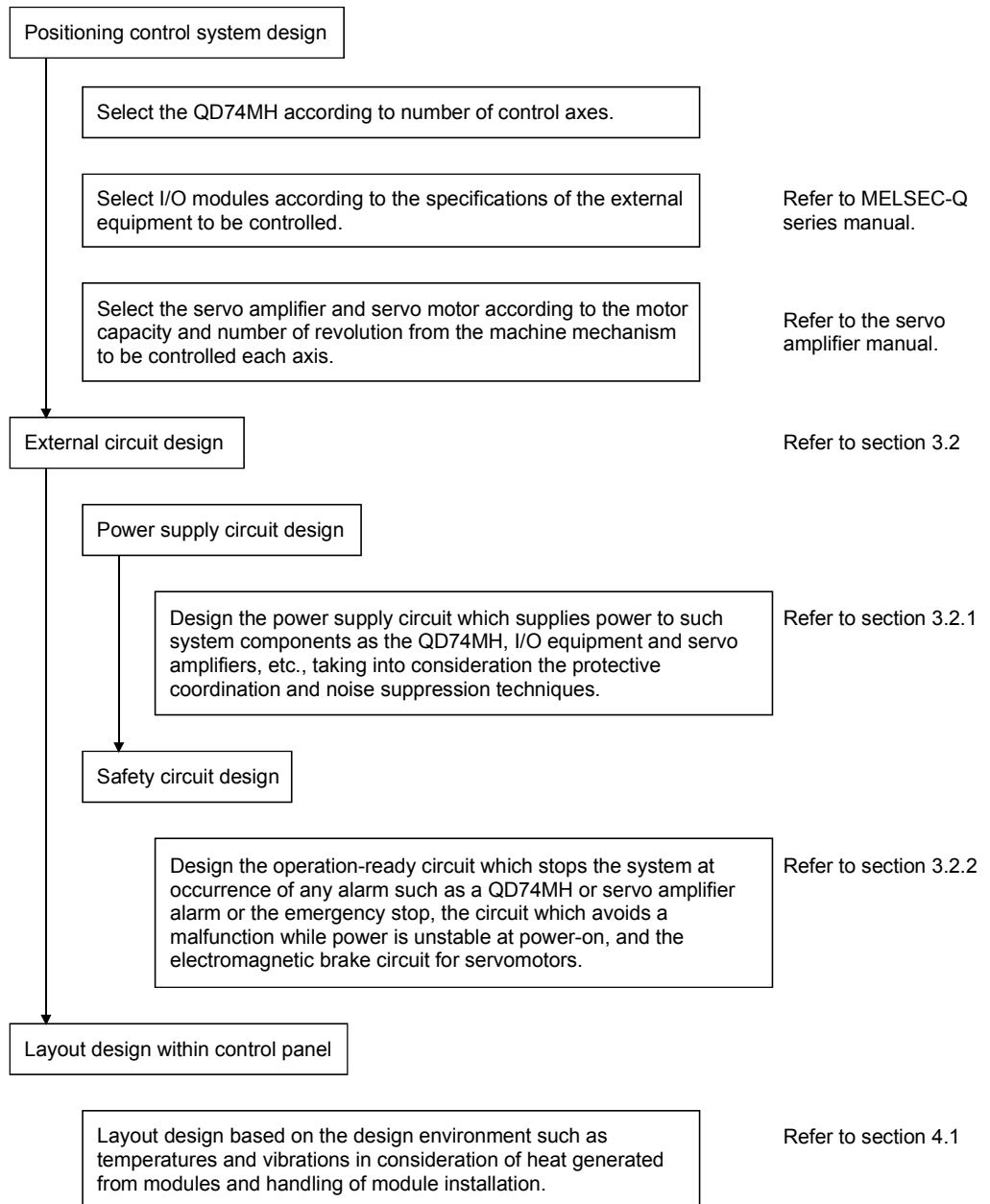

3.2 External Circuit Design

Configure up the power supply circuit and main circuit which turn off the power supply after detection alarm occurrence and servo forced stop. When designing the main circuit of the power supply, make sure to use a no fuse breaker (NFB). The outline diagrams of the internal circuits for the external device connection interface are shown below.

(1) Example when using the forced stop of the QD74MH

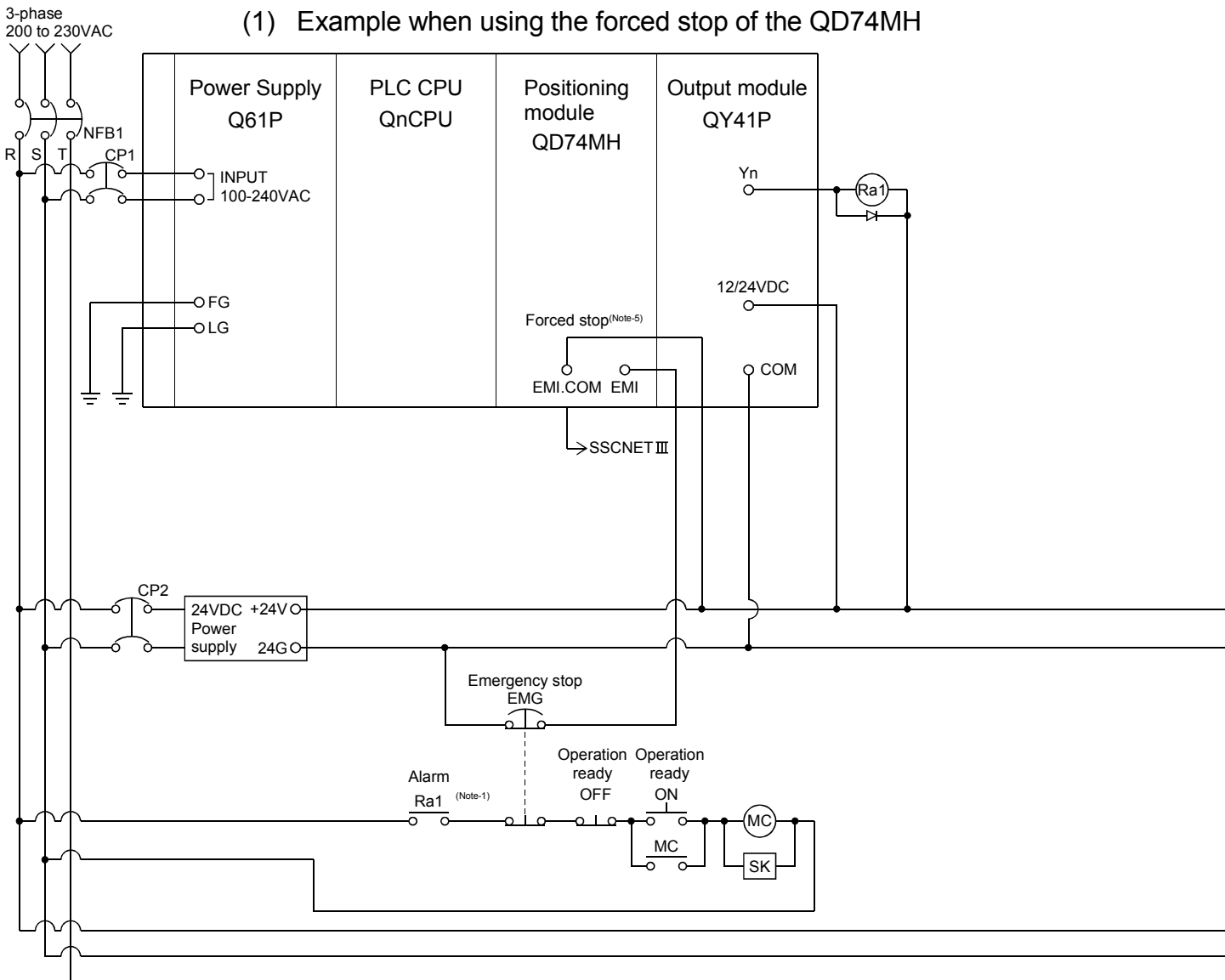

POINT

- (1) (Note-1): Configure up the power supply circuit which switch off the electromagnetic contactor (MC) after detection alarm occurrence on the PLC CPU.
- (2) (Note-2): It is also possible to use a full wave rectified power supply as the power supply for the electromagnetic brake.
- (3) (Note-3): It is also possible to use forced stop signal of the servo amplifier.
- (4) (Note-4): Set the servo amplifier by setting the rotary switch of servo amplifier referring Section 4.2.1.
- (5) (Note-5): The status of forced stop input signal can be confirmed with "[Md.103] Forced stop input status".
- (6) (Note-6): It recommends using one leakage breaker for one servo amplifier. When electric power is supplied to multiple servo amplifiers for one leakage breaker, select the wire connected to the servo amplifier according to the capacity of the leakage breaker.

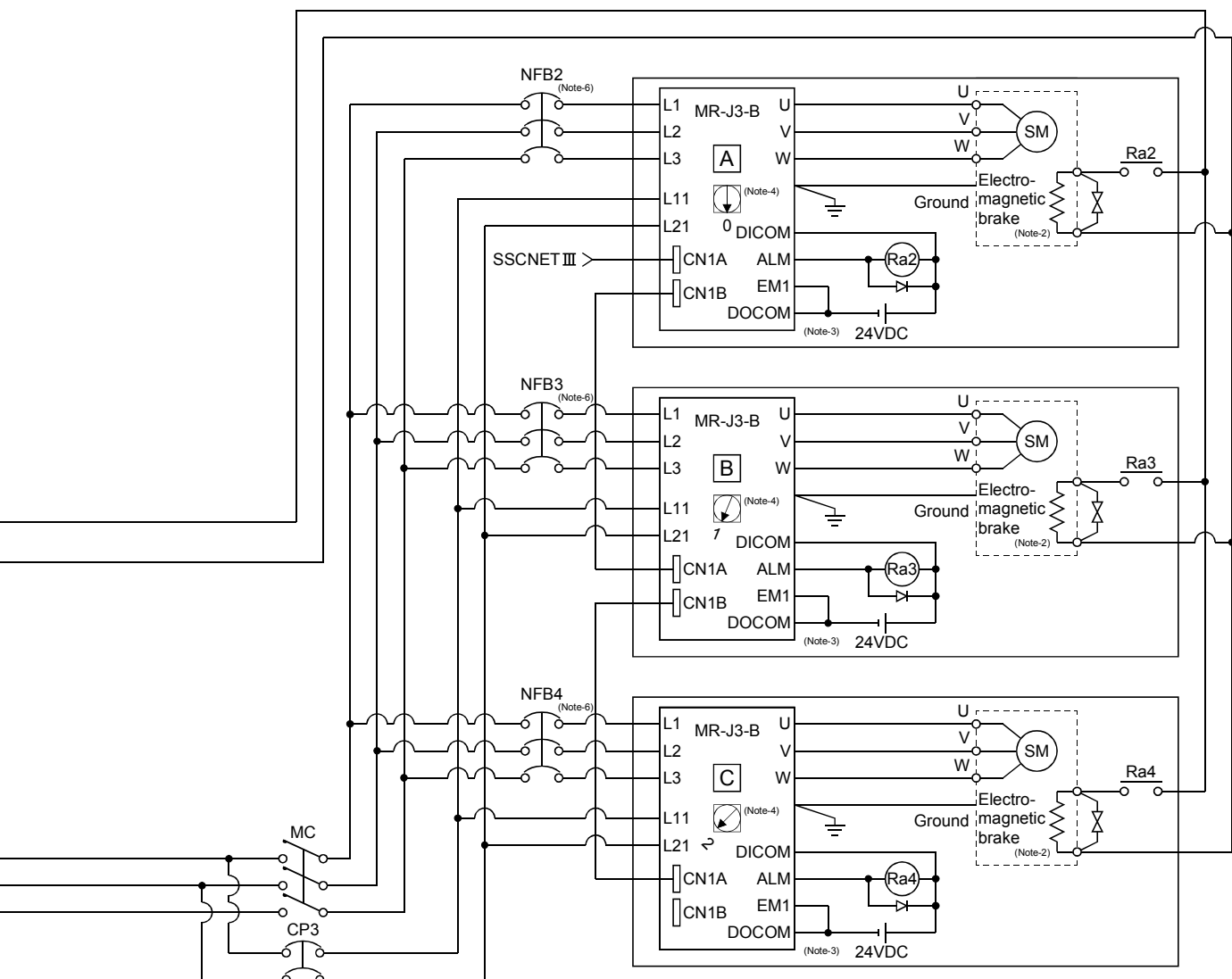

- (Note-1): When the control power supply of servo amplifier is shut off, it is not possible to communicate with the servo amplifier after that.
 Example) When the control power supply L11/L21 of servo amplifier in above figure is shut off, it is also not possible to communicate with the servo amplifier. If only a specific servo amplifier control power supply is shut off, be sure to shut off the main circuit power supply L1/L2/L3, and do not shut off the control power supply L11/L21.
- (Note-2): Be sure to shut off the both of main circuit power supply L1/L2/L3 and control power supply L11/L21 at the time of exchange of servo amplifier. At this time, it is not possible to communicate between the servo amplifier and QD74MH. Therefore, be sure to exchange the servo amplifier after stopping the operating of machine beforehand.
- (Note-3): If the forced stop input signal by external 24VDC turns OFF when setting of "[Pr.101] External forced stop selection" to "0 : Valid", servomotor is stopped with dynamic brake. (The LED display of servo amplifier indicates "E7" (Controller forced stop warning).)

(2) Example when using the forced stop of the QD74MH and MR-J3-B

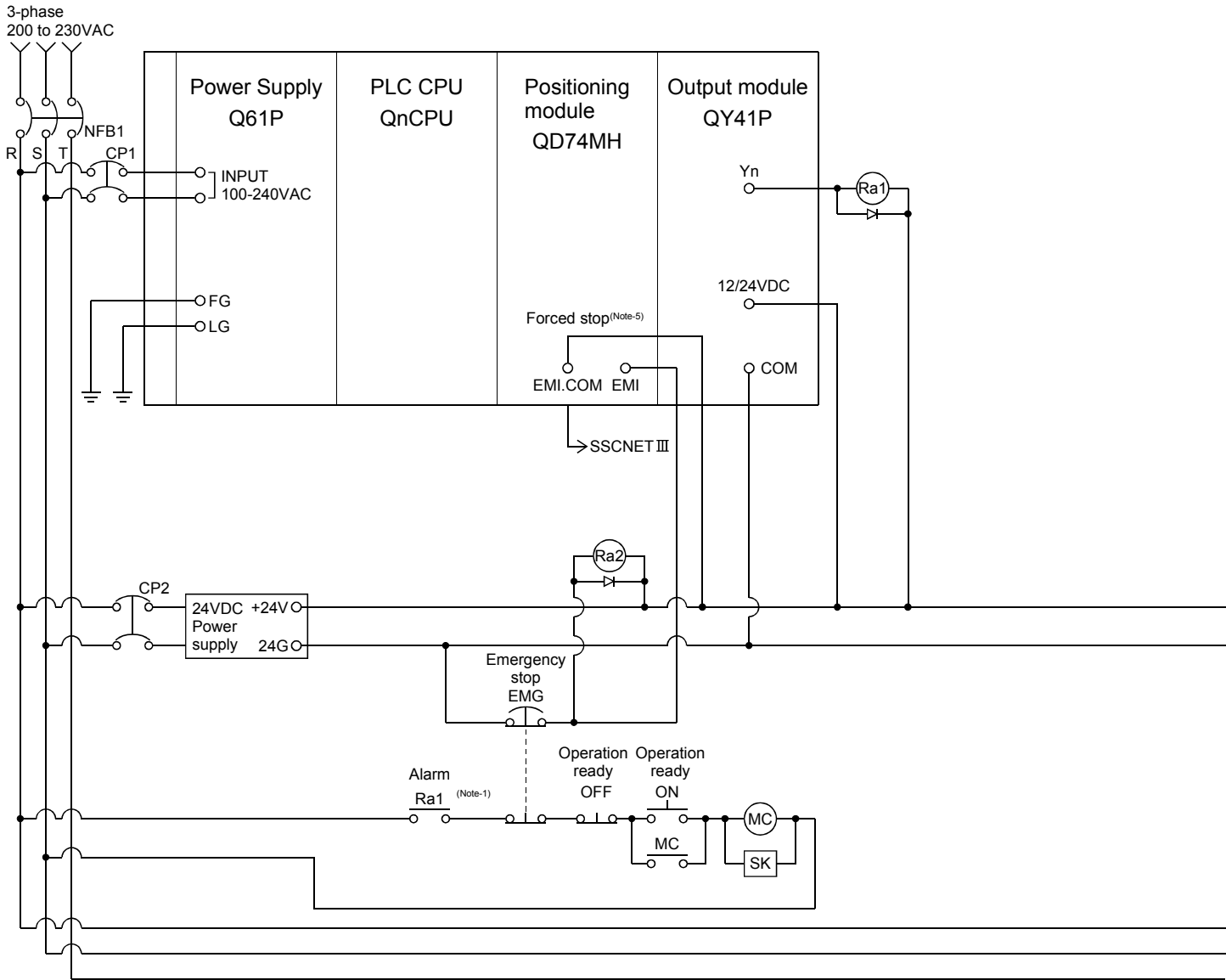

POINT

- (1) (Note-1): Configure up the power supply circuit which switch off the electromagnetic contactor (MC) after detection alarm occurrence on the PLC CPU.
- (2) (Note-2): It is also possible to use a full wave rectified power supply as the power supply for the electromagnetic brake.
- (3) (Note-3): Set the servo amplifier by setting the rotary switch of servo amplifier referring Section 4.2.1.
- (4) (Note-4): It recommends using one leakage breaker for one servo amplifier. When electric power is supplied to multiple servo amplifiers for one leakage breaker, select the wire connected to the servo amplifier according to the capacity of the leakage breaker.
- (5) (Note-5): The status of forced stop input signal can be confirmed with "Md.103 Forced stop input status".

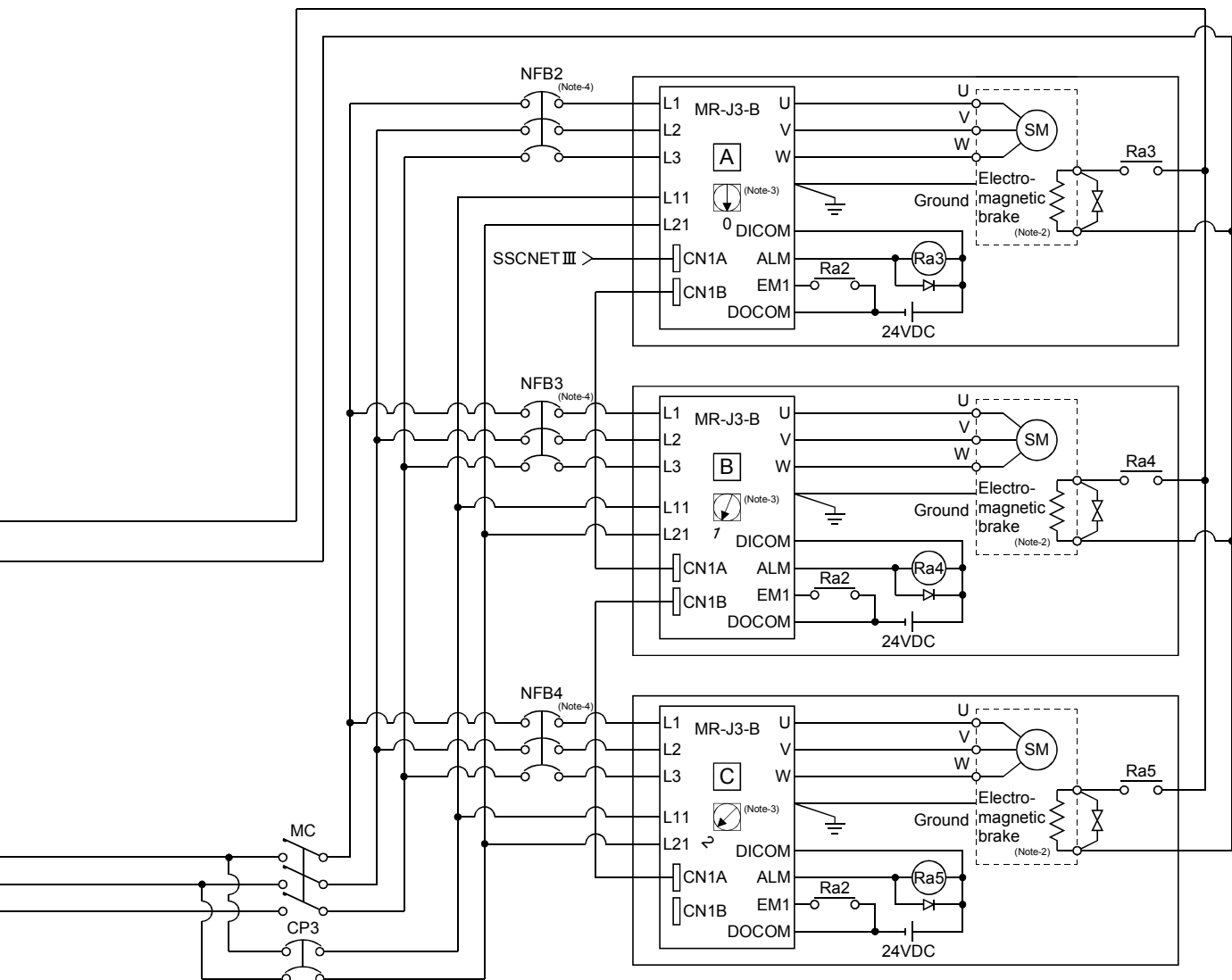

- (Note-1): When the control power supply of servo amplifier is shut off, it is not possible to communicate with the servo amplifier after that.
Example) When the control power supply L11/L21 of servo amplifier in above figure is shut off, it is also not possible to communicate with the servo amplifier. If only a specific servo amplifier control power supply is shut off, be sure to shut off the main circuit power supply L1/L2/L3, and do not shut off the control power supply L11/L21.
- (Note-2): Be sure to shut off the both of main circuit power supply L1/L2/L3 and control power supply L11/L21 at the time of exchange of servo amplifier. At this time, it is not possible to communicate between the servo amplifier and QD74MH. Therefore, be sure to exchange the servo amplifier after stopping the operating of machine beforehand.
- (Note-3): The dynamic brake is operated, and servomotor occurs to the free run when EM1 (forced stop) of servo amplifier turn OFF. At the time, the display shows the servo forced stop warning (E6). During ordinary operation, do not used forced stop signal to alternate stop and run. The service life of the servo amplifier may be shortened.

3.2.1 Power supply circuit design

This section describes the protective coordination and noise suppression techniques of the power supply circuit.

(1) Separation and protective coordination (leakage current protection, over current protection) of power supply lines

Separate the lines for PLC system power supplies from the lines for I/O devices and servo amplifiers as shown below.

When there is much noise, connect an insulation transformer.

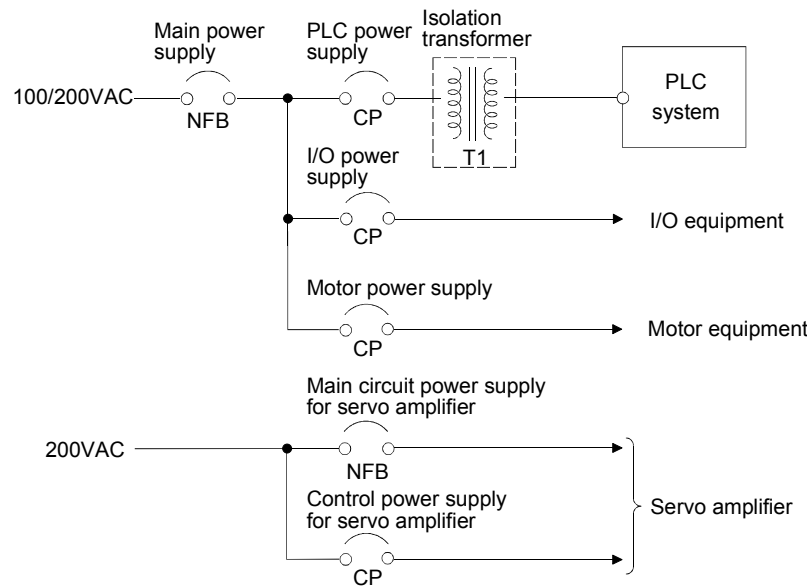

(2) Grounding

The PLC system may malfunction as it is affected by various noises such as electric path noises from the power supply systems, radiated and induced noises from other equipment, servo amplifiers and their cables, and electromagnetic noises from conductors. To avoid such troubles, connect the earthing ground of each equipment and the shield grounds of the shielded cables to the earth. For grounding, use the exclusive ground terminal wire of each equipment or a single-point earth method to avoid grounding by common wiring, where possible, since noises may sneak from other equipment due to common impedances.

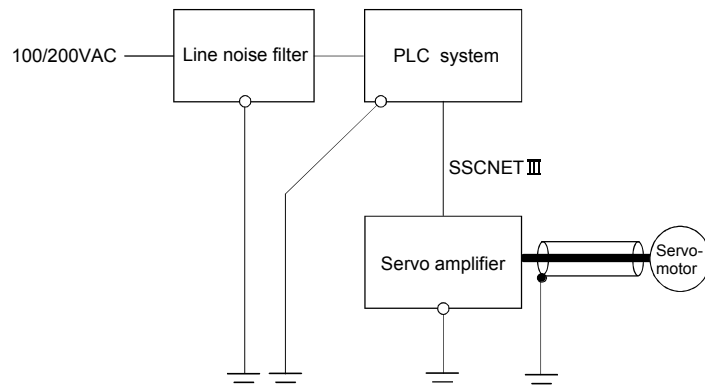

3.2.2 Safety circuit design

(1) Concept of safety circuits

When the PLC system is powered on and off, normal control output may not be done momentarily due to a delay or a startup time difference between the PLC power supply and the external power supply (DC in particular) for the control target.

Also, an abnormal operation may be performed if an external power supply fault or positioning module failure takes place.

To prevent any of these abnormal operations from leading to the abnormal operation of the whole system and in a fail-safe viewpoint, areas which can result in machine breakdown and accidents due to abnormal operations (e.g. emergency stop, protective and interlock circuits) should be constructed outside the PLC system.

(2) Emergency stop circuit

The circuit should be constructed outside of the PLC system or servo amplifier. Shut off the power supply to the external servo amplifier by this circuit, make the electromagnetic brakes of the servomotor operated.

(3) Forced stop circuit

(a) The forced stop of all servo amplifiers is possible in a lump by using the EMI forced stop input by external 24VDC of QD74MH. After forced stop, the forced stop factor is removed and the forced stop canceled.

(The servo error detection signal does not turn on with the forced stop.)

The forced stop input can be selected "valid/invalid" in the parameter setting.

Make the forced stop input cable within 30m(98.43ft.).

The wiring example for the forced stop input of QD74MH is shown below.

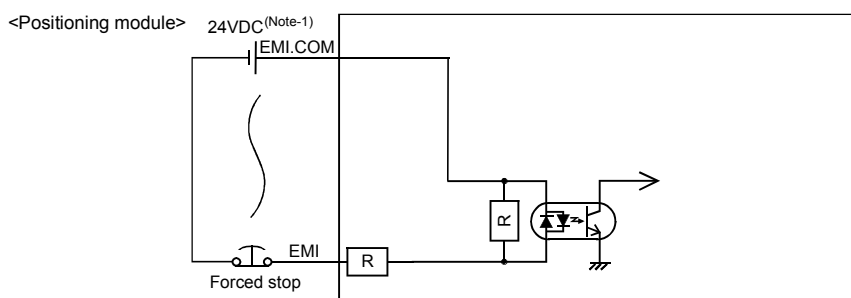
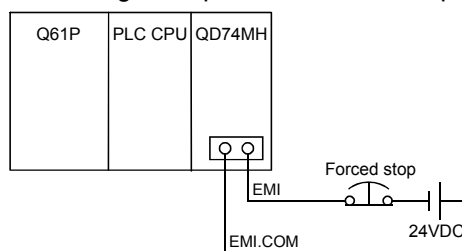

(Note): The forced stop input can be selected "valid/invalid" in the parameter settings.

(Note-1): Both of positive common and negative common can be used.

- (b) The forced stop of all servo amplifiers is possible in a lump by using the forced stop input signal [Y2] of QD74MH. After forced stop, the forced stop factor is removed and the forced stop canceled.
(The servo error detection signal does not turn on with the forced stop.)

The wiring example and program example that uses the forced stop input of input module (QX10) is shown below.

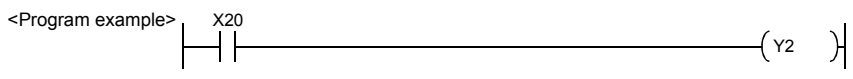
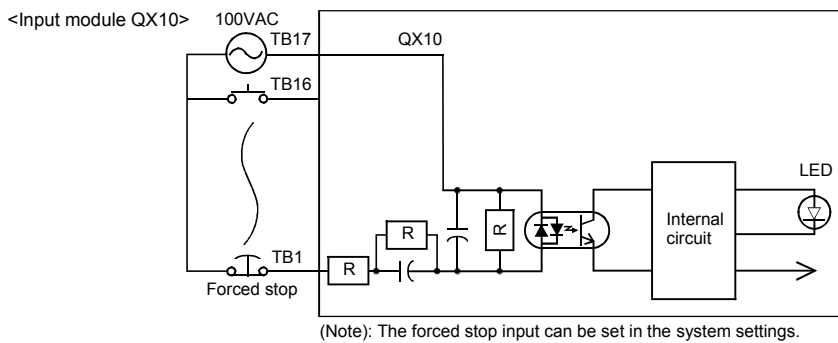
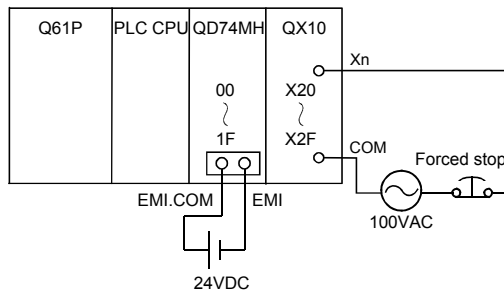

- (c) It is also possible to use the forced stop signal of the servo amplifier. Refer to manual of the servo amplifier about servomotor capacity.

Operation status of the forced stop and the forced stop are as follows.

Item	Operation of the signal ON	Remark
Emergency stop	Servo OFF	Shut off the power supply to the external servo amplifier by external circuit, make the servomotor stopped.
Forced stop		The servomotor is stopped according to the stop instruction from QD74MH to the servo amplifier.

4. INSTALLATION, WIRING, START-UP AND MAINTENANCE

This section describes the installation, wiring, start-up and maintenance of the product.

4.1 Handling Precautions

(1) Main body

- The main body case is made of plastic. Take care not to drop or apply strong impacts onto the case.
- Do not remove the PCB from the case. Failure to observe this could lead to faults.

(2) Cable

- Do not press on the cable with a sharp object.
- Do not twist the cable with force.
- Do not forcibly pull on the cable.
- Do not step on the cable.
- Do not place objects on the cable.
- Do not damage the cable sheath.

(3) Installation environment

Do not install the module in the following type of environment.

- Where the ambient temperature exceeds the 0 to 55°C range.
- Where the ambient humidity exceeds the 5 to 95%RH range.
- Where there is sudden temperature changes, or where dew condenses.
- Where there is corrosive gas or flammable gas.
- Where there are high levels of dust, conductive powder, such as iron chips, oil mist, salt or organic solvents.
- Where the module will be subject to direct sunlight.
- Where there are strong electric fields or magnetic fields.
- Where vibration or impact could be directly applied onto the main body.

⚠ DANGER

- Completely turn off the externally supplied power used in the system before clearing or tightening the screws. Not doing so could result in electric shock.

⚠ CAUTION

- Use the programmable controller in an environment that meets the general specifications contained in CPU module User's Manual to use.
Using the programmable controller in an environment outside the range of the general specifications could result in electric shock, fire, operation failure, and damage to or deterioration of the product.
- Do not directly touch the module's conductive parts and electronic components. Doing so may could cause an operation failure or give damage to the module.
- Be sure there are no foreign matters such as sawdust or wiring debris inside the module. Such debris could cause fire, damage, or operation failure.
- Never try to disassemble or modify module. It may cause product failure, operation failure, injury or fire.
- Completely turn off the externally supplied power used in the system before installation or removing the module. Not doing so could result in damage to the module.
- Because the connector has its orientation, check it before attaching or detaching the connector straight from the front. Unless it is properly installed, a poor contact may occur, resulting in erroneous input and output.
- While pressing the installation lever located at the bottom of module, insert the module fixing tab into the fixing hole in the base unit until it stops. Then, securely install the module with the fixing hole as a supporting point. Incorrect installation of the module can cause an operation failure, damage or drop. When using the module in the environment of much vibration or impact, tighten the module with a screw. Tighten the screw in the specified torque range. Under tightening may cause a drop, short circuit or operation failure. Over tightening may cause a drop, short circuit or operation failure due to damage to the screw or module.
- Lock the control panel and prevent access to those who are not certified to handle or install electric equipment.

4.2 Wiring

The precautions for wiring are given below.

DANGER

- Completely turn off the externally supplied power used in the system before installation or wiring. Not doing so could result in electric shock or damage to the product.

CAUTION

- Check the layout of the terminals and then properly route the wires to the module.
- Solder connector for external input signal cable properly. Insufficient soldering may cause malfunction.
- Be careful not to let foreign matters such as sawdust or wire chips get inside the module. These may cause fires, failure or malfunction.
- The top surface of the module is covered with protective films to prevent foreign objects such as cable off cuts from entering the module when wiring. Do not remove this film until the wiring is complete. Before operating the system, be sure to remove the film to provide adequate ventilation.
- When removing the cable or power supply cable from the module, do not pull the cable. When removing the cable with a connector, hold the connector on the side that is connected to the module. Pulling the cable that is still connected to the module may cause malfunction or damage to the module or cable.
- The external input signal cable of the QD74MH and SSCNET III cable should not be routed near or bundled with the main circuit cable, power cable and/or other such load – carrying cables other than those for the PLC. These cables should be separated by at least 100mm (3.94inch) or more. They can cause electrical interference, surges and inductance that can lead to mis-operation.
- The shielded cable for connecting QD74MH can be secured in place. If the shielded cable is not secured, unevenness or movement of the shielded cable or careless pulling on it could result in damage to the QD74MH, servo amplifier or shielded cable or defective cable connections could cause mis-operation of the unit.

4.2.1 SSCNETⅢ cable

(1) Precautions of SSCNETⅢ cable wiring

SSCNETⅢ cable is made from optical fiber. If optical fiber is added a power such as a major shock, lateral pressure, haul, sudden bending or twist, its inside distorts or breaks, and optical transmission will not be available. Especially, as optical fiber for MR-J3BUS□M, MR-J3BUS□M-A is made of synthetic resin, it melts down if being left near the fire or high temperature. Therefore, do not make it touched the part, which becomes high temperature, such as radiator or regenerative option of servo amplifier and servomotor.

Be sure to use optical fiber within the range of operating temperature described in this manual.

Read described item of this section carefully and handle it with caution.

(a) Minimum bend radius

Make sure to lay the cable with greater radius than the minimum bend radius. Do not press the cable to edges of equipment or others. For SSCNETⅢ cable, the appropriate length should be selected with due consideration for the dimensions and arrangement of QD74MH or servo amplifier. When closing the door of control panel, pay careful attention for avoiding the case that SSCNETⅢ cable is hold down by the door and the cable bend becomes smaller than the minimum bend radius.

Model name of SSCNETⅢ cable	Minimum bend radius [mm(inch)]
MR-J3BUS□M	25(0.98)
MR-J3BUS□M-A	Enforced covering cord: 50 (1.97), Cord: 25 (0.98)
MR-J3BUS□M-B	Enforced covering cord: 50 (1.97), Cord: 30 (1.18)

(b) Tension

If tension is added on the SSCNETⅢ cable, the increase of transmission loss occurs because of external force which concentrates on the fixing part of SSCNETⅢ cable or the connecting part of SSCNETⅢ connector. At worst, the breakage of SSCNETⅢ cable or damage of SSCNETⅢ connector may occur. For cable laying, handle without putting forced tension. (Refer to this section "(5) Specifications of SSCNETⅢ cable" for the tension strength.)

(c) Lateral pressure

If lateral pressure is added on the SSCNETⅢ cable, the cable itself distorts, internal optical fiber gets stressed, and then transmission loss will increase. At worst, the breakage of SSCNETⅢ cable may occur. As the same condition also occurs at cable laying, do not tighten up SSCNETⅢ cable with a thing such as nylon band (TY-RAP).

Do not trample it down or tuck it down with the door of control box or others.

(d) Twisting

If the SSCNET III cable is twisted, it will become the same stress added condition as when local lateral pressure or bend is added. Consequently, transmission loss increases, and the breakage of SSCNET III cable may occur at worst.

(e) Disposal

When incinerating optical cable (cord) used for SSCNET III cable, hydrogen fluoride gas or hydrogen chloride gas which is corrosive and harmful may be generated. For disposal of SSCNET III cable, request for specialized industrial waste disposal services who has incineration facility for disposing hydrogen fluoride gas or hydrogen chloride gas.

(f) Wiring process of SSCNET III cable

Put the SSCNET III cable in the duct or fix the cable at the closest part to the QD74MH with bundle material in order to prevent SSCNET III cable from putting its own weight on SSCNET III connector.

Leave the following space for wiring.

- Putting in the duct

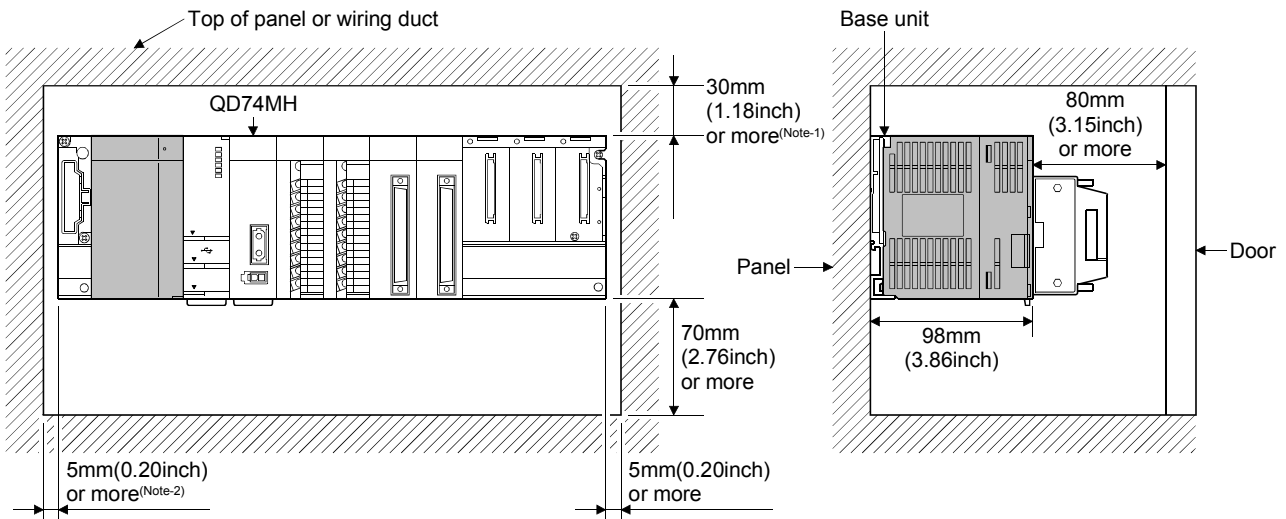

(Note-1) : For wiring duct with 50[mm] (1.97 inch) or less height.
 40[mm] (1.58 inch) or more for other cases.

(Note-2) : 20mm (0.79inch) or more when the adjacent module is not removed and the extension cable is connected.

- Bundle fixing

Optical cord should be given loose slack to avoid from becoming smaller than the minimum bend radius, and it should not be twisted. When laying cable, fix and hold it in position with using cushioning such as sponge or rubber which does not contain plasticizing material.

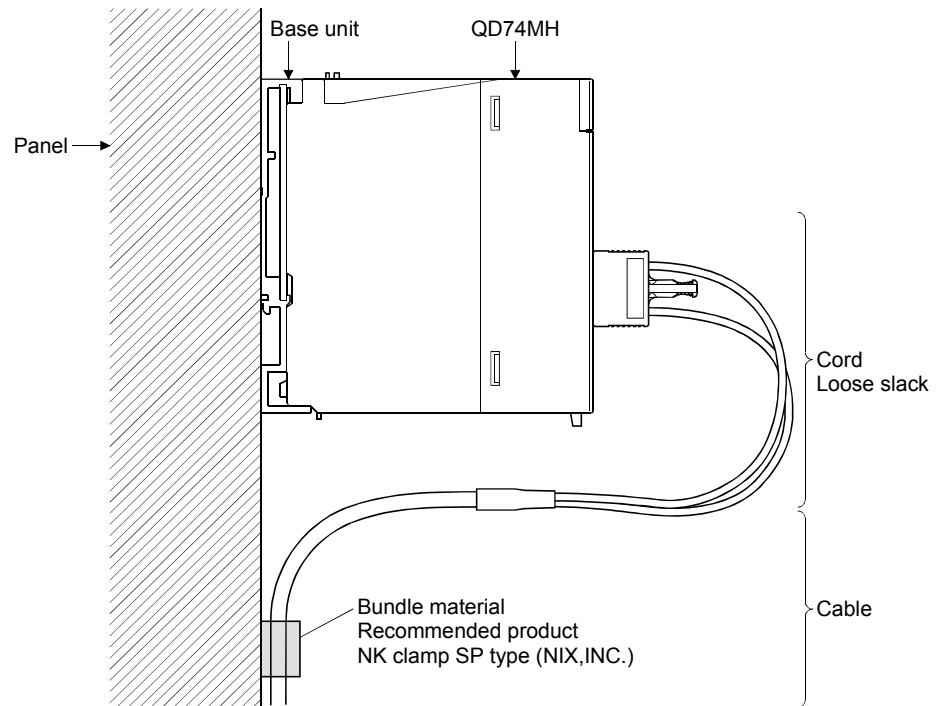

(2) Connection of SSCNET III cables

The connection method of SSCNET III cable between QD74MH and servo amplifier is explained as follows.

When absolute position detection control is executed, installed battery (MR-J3BAT) to servo amplifier.

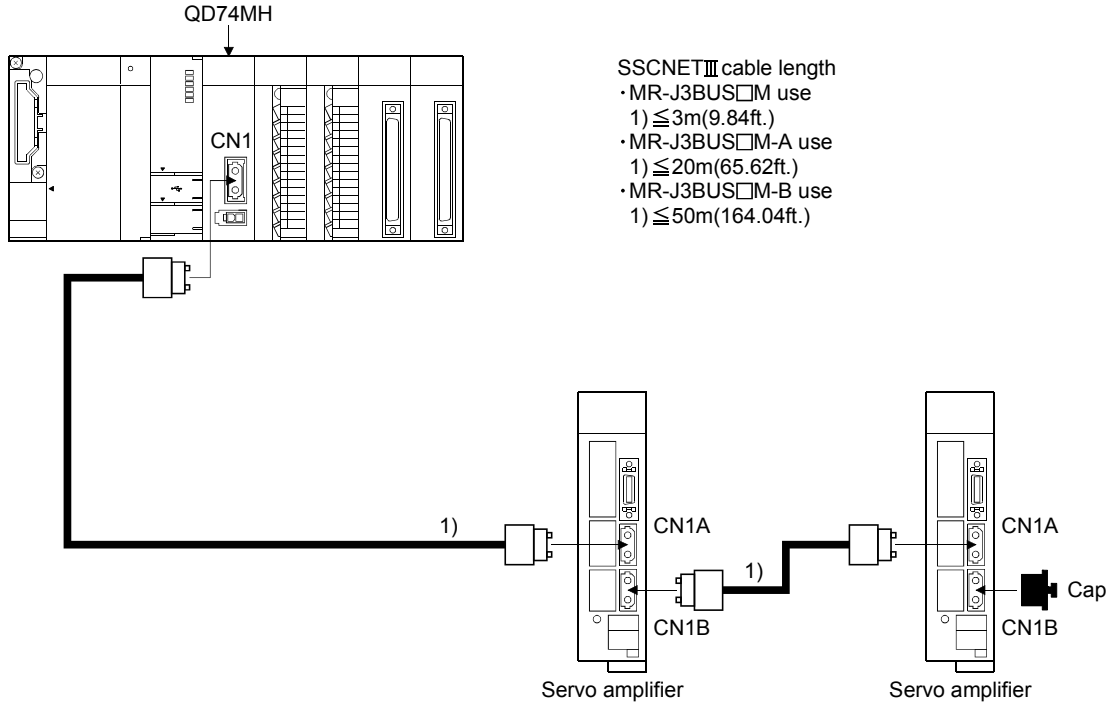

(Note): It cannot communicate with that the connection of CN1A and CN1B is mistaken.

Table 4.1 List of SSCNET III cable module name

No.	Model name ^(Note)	Cable length	Description	
1)	MR-J3BUS□M	0.15m(0.49ft.), 0.3m(0.98ft.), 0.5m(1.64ft.), 1m(3.28ft.), 3m(9.84ft.)	Standard cord for inside panel	<ul style="list-style-type: none"> • QD74MH ↔ MR-J3-□B • MR-J3-□B ↔ MR-J3-□B
	MR-J3BUS□M-A	5m(16.4ft.), 10m(32.81ft.), 20m(65.62ft.)	Standard cable for outside panel	
	MR-J3BUS□M-B	30m(98.43ft.), 40m(131.23ft.), 50m(164.04ft.)	Long distance cable	

(Note): □ = Cable length

(3) Setting of the axis number and axis select rotary switch of servo amplifier

Axis number is used to set the axis numbers of servo amplifiers connected to SSCNET III connector(CN1) in the program.

Axis number of 1 to 16 can be set for QD74MH16, and axis number of 1 to 8 can be set for QD74MH8.

Set the axis number by using the axis select rotary switch of servo amplifier.

Axis number and number of axis select rotary switch is allocated as shown in the table below. Set not to overlap the axis number of servo amplifier.

Wrong setting of servo amplifier may not operate normally.

Table 4.2 Correspondence between axis number and axis select rotary switch

Axis number	Axis select rotary switch
1	0
2	1
3	2
4	3
5	4
6	5
7	6
8	7
9	8
10	9
11	A
12	B
13	C
14	D
15	E
16	F

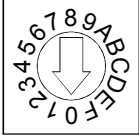

(4) Precautions for handling the SSCNET III cable

- Do not stamp the SSCNET III cable.
- When laying the SSCNET III cable, be sure to secure the minimum cable bend radius or more. If the bend radius is less than the minimum cable bend radius, it may cause malfunctions due to characteristic deterioration, wire breakage, etc.
- For connection and disconnection of SSCNET III cable, hold surely a tab of cable connector.

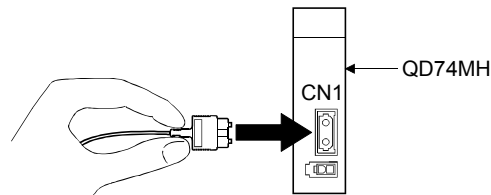

(a) Connection of SSCNET III cable

- For connection of SSCNET III cable to the QD74MH, connect it to the SSCNET III connector CN1 of QD74MH while holding a tab of SSCNET III cable connector. Be sure to insert it until it clicks.
- If the cord tip for the SSCNET III cable is dirty, optical transmission is interrupted and it may cause malfunctions. If it becomes dirty, wipe with a bonded textile, etc. Do not use solvent such as alcohol.

(b) Disconnection of SSCNET III cable

- For disconnection of SSCNET III cable, pull out it while holding a tab of SSCNET III cable connector or the connector.
- After disconnection of SSCNET III cable, be sure to put a cap (attached to QD74MH or servo amplifier) to the QD74MH and servo amplifier.
- For SSCNET III cable, attach the tube for protection optical cord's end face on the end of connector.

⚠ CAUTION

- Securely connect the connector for SSCNET III cable to the bottom connector on the module.
- Be sure to connect SSCNET III cable with the connector. If the connection is mistaken, between the QD74MH and servo amplifier cannot be communicated.
- After removal of the SSCNET III cable, be sure to put a cap on the SSCNET III connector. Otherwise, adhesion of dirt deteriorates in characteristic and it may cause malfunctions.
- Do not remove the SSCNET III cable while turning on the power supply of QD74MH and servo amplifier. Do not see directly the light generated from SSCNET III connector and the end of SSCNET III cable. When the light gets into eye, may feel something is wrong for eye. (The light source of SSCNET III cable complies with class1 defined in JISC6802 or IEC60825-1.)
- If the SSCNET III cable is added a power such as a major shock, lateral pressure, haul, sudden bending or twist, its inside distorts or breaks, and optical transmission will not be available. Be sure to take care enough so that the short SSCNET III cable is added a twist easily.

⚠ CAUTION

- Be sure to use the SSCNET III cable within the range of operating temperature described in this manual. Especially, as optical fiber for MR-J3BUS□M and MR-J3BUS□M-A are made of synthetic resin, it melts down if being left near the fire or high temperature. Therefore, do not make it touched the part which becomes high temperature, such as radiator or regenerative option of servo amplifier, or servomotor.
- When laying the SSCNET III cable, be sure to secure the minimum cable bend radius or more. (Refer to Section 4.2.1)
- Put the SSCNET III cable in the duct or fix the cable at the closest part to the QD74MH with bundle material in order to prevent SSCNET III cable from putting its own weight on SSCNET III connector. When laying cable, the optical cord should be given loose slack to avoid from becoming smaller than the minimum bend radius, and it should not be twisted. Also, fix and hold it in position with using cushioning such as sponge or rubber which does not contain plasticizing material.
- Migrating plasticizer is used for vinyl tape. Keep the MR-J3BUS□M, and MR-J3BUS□M-A cables away from vinyl tape because the optical characteristic may be affected.

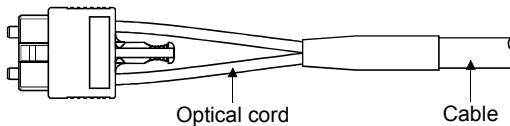

SSCNET III cable	Cord	Cable
MR-J3BUS□M	△	/
MR-J3BUS□M-A	△	△
MR-J3BUS□M-B	○	○

○: Normally, cable is not affected by plasticizer.

△: Phthalate ester plasticizer such as DBP and DOP may affect optical characteristic of cable.

Generally, soft polyvinyl chloride (PVC), polyethylene resin (PE) and fluorine resin contain non-migrating plasticizer and they do not affect the optical characteristic of SSCNET III cable. However, some wire sheaths and cable ties, which contain migrating plasticizer (phthalate ester), may affect MR-J3BUS□M and MR-J3BUS□M-A cables (made of plastic).

In addition, MR-J3BUS□M-B cable (made of quartz glass) is not affected by plasticizer.

- If the adhesion of solvent and oil to the cord part of SSCNET III cable may lower the optical characteristic and machine characteristic. If it is used such an environment, be sure to do the protection measures to the cord part.
- When keeping the QD74MH or servo amplifier, be sure to put on a cap to connector part so that a dirt should not adhere to the end of SSCNET III connector.
- SSCNET III connector to connect the SSCNET III cable is put a cap to protect light device inside connector from dust. For this reason, do not remove a cap until just before connecting SSCNET III cable. Then, when removing SSCNET III cable, make sure to put a cap.
- Keep the cap and the tube for protecting light cord end of SSCNET III cable in a plastic bag with a zipper of SSCNET III cable to prevent them from becoming dirty.

⚠ CAUTION

- When exchanging the QD74MH or servo amplifier, make sure to put cap on SSCNET III connector. When asking repair of QD74MH or servo amplifier for some troubles, make also sure to put a cap on SSCNET III connector. When the connector is not put a cap, the light device may be damaged at the transit. In this case, exchange and repair of light device is required.
- Forcibly removal the SSCNET III cable from the QD74MH will damage the QD74MH and SSCNET III cables.

(5) Specifications of SSCNET III cable

Generally use the SSCNET III cables available as our products.

(a) Model

Cable model	Cable length [m(ft.)]	Flex life	Remark
MR-J3BUS□M	MR-J3BUS015M	0.15 (0.49)	Standard cord for inside panel
	MR-J3BUS03M	0.3 (0.98)	
	MR-J3BUS05M	0.5 (1.64)	
	MR-J3BUS1M	1 (3.28)	
	MR-J3BUS3M	3 (9.84)	
MR-J3BUS□M-A	MR-J3BUS5M-A	5 (16.40)	Standard cable for outside panel
	MR-J3BUS10M-A	10 (32.81)	
	MR-J3BUS20M-A	20 (65.62)	
MR-J3BUS□M-B ^(Note-1)	MR-J3BUS30M-B	30 (98.43)	Long flex
	MR-J3BUS40M-B	40 (131.23)	
	MR-J3BUS50M-B	50 (164.04)	

(Note-1): For the cable of less than 30[m](98.43[ft.]), contact your nearest Mitsubishi sales representative.

(b) Specifications

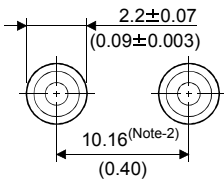
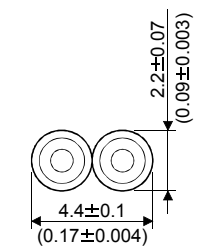
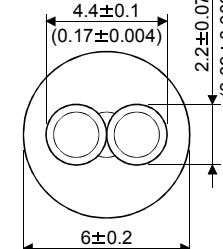
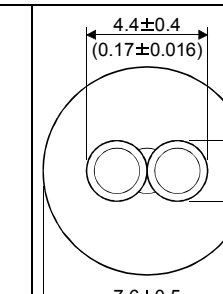
		Description			
SSCNET III cable model		MR-J3BUS□M		MR-J3BUS□M-A	MR-J3BUS□M-B
SSCNET III cable length [m(ft.)]		0.15 (0.49)	0.3 to 3 (0.98 to 9.84)	5 to 20 (16.40 to 65.62)	30 to 50 (98.43 to 164.04)
Optical cable (Cord)	Minimum bend radius [mm(inch)]	25(0.98)		Enforced covering cord: 50 (1.97) Cord: 25 (0.98)	Enforced covering cord: 50 (1.97) Cord: 30 (1.18)
	Tension strength [N]	70	140	420 (Enforced covering cord)	980 (Enforced covering cord)
	Temperature range for use [°C(°F)] (Note-1)	-40 to 80 (-40 to 176)			-20 to 70 (-4 to 158)
	Ambient	Indoors (no direct sunlight), No solvent or oil			
	External appearance [mm(inch)]				

(Note-1): This temperature range for use is the value for optical cable (cord) only.

(Note-2): Dimension of connector fiber insert location. The distance of two cords is changed by how to bend it.

⚠ CAUTION

- Use the processing method and the processing treatment device that exists in the connector when you fix the cord part of the SSCNET III cable to the connector.
- It must not cut squarely when you cut the cord part of the SSCNET III cable, the cutting edge side must not be made smooth, and garbage etc. must not adhere.
- The damage etc. must not adhere to the optical cord part when you peel off the film of the cable of the SSCNET III cable.
- If the end face of cord tip for the SSCNET III cable is dirty, optical transmission is interrupted and it may cause malfunctions. If it becomes dirty, wipe with a bonded textile, etc. Do not use solvent such as alcohol.
- Please do not add impossible power to the connector of the SSCNET III cable.
- When incinerating the SSCNET III cable (optical fiber), hydrogen fluoride gas or hydrogen chloride gas which is corrosive and harmful may be generated. For disposal of the SSCNET III cable (optical fiber), request for specialized industrial waste disposal services who has incineration facility for disposing hydrogen fluoride gas or hydrogen chloride gas.

1) MR-J3BUS□M

a) Model explanation

Type: MR-J3BUS□M-*

Symbol	Cable type
None	Standard cord for inside panel
A	Standard cable for outside panel
B	Long distance cable

Symbol	Cable length [m(ft.)]
015	0.15(0.49)
03	0.3(0.98)
05	0.5(1.64)
1	1(3.28)
3	3(9.84)
5	5(16.40)
10	10(32.81)
20	20(65.62)
30	30(98.43)
40	40(131.23)
50	50(164.04)

b) Exterior dimensions
 • MR-J3BUS015M

[Unit: mm(inch)]

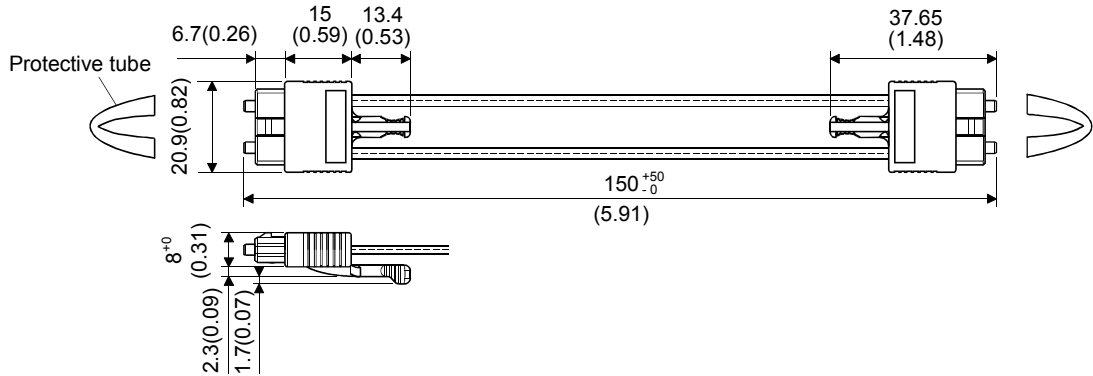

• MR-J3BUS03M to MR-J3BUS3M

Refer to the table of this section (5) for cable length (L).

[Unit: mm(inch)]

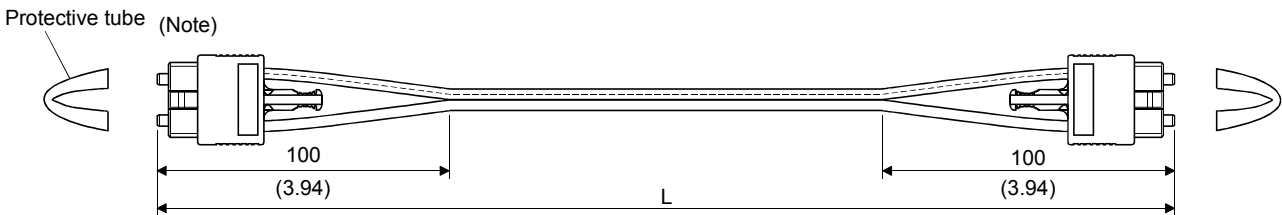

(Note) : Dimension of connector part is the same as that of MR-J3BUS015M.

• MR-J3BUS5M-A to MR-J3BUS20M-A, MR-J3BUS30M-B to MR-J3BUS50M-B

Refer to the table of this section (5) for cable length (L).

SSCNET III cable	Variation [mm(inch)]	
	A	B
MR-J3BUS5M-A to MR-J3BUS20M-A	100(3.94)	30(1.18)
MR-J3BUS30M-B to MR-J3BUS50M-B	150(5.91)	50(1.97)

[Unit: mm(inch)]

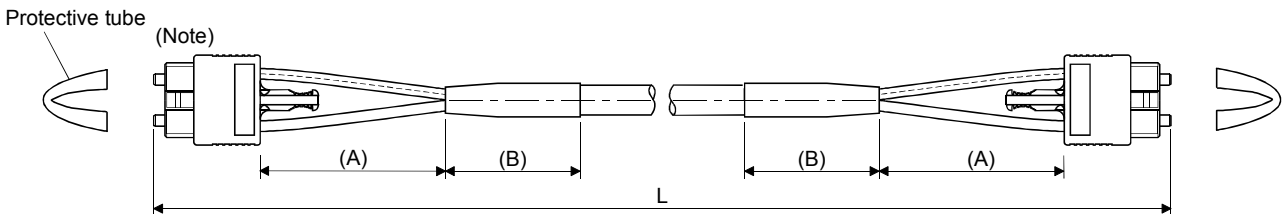

(Note) : Dimension of connector part is the same as that of MR-J3BUS015M.

POINT

Keep the cap and the tube for protecting light code end of SSCNET III cable in a plastic bag with a zipper of SSCNET III cable to prevent them from becoming dirty.

2) SSCNET III cable connector

[Unit: mm(inch)]

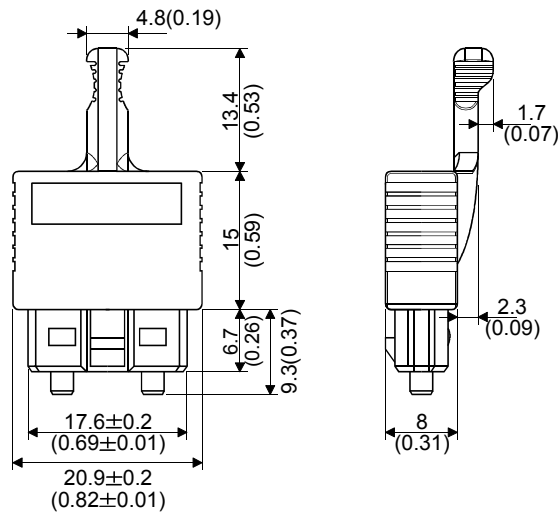

4.2.2 Forced stop input cable

(1) Precautions for handling the forced stop input cable

For connection or removal of the forced stop input cable, do it surely while holding a connector of forced stop input cable.

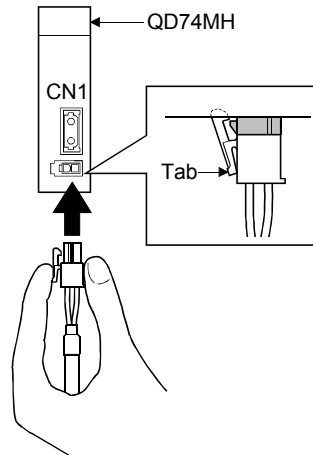

(2) Connection of the forced stop input cable

For connection of a forced stop input cable to the QD74MH, connect it surely to a EMI connector of QD74MH while holding a connector.

Be sure to insert it until it clicks.

(3) Removal of the forced stop input cable

For removal of the forced stop input cable, push a tab and pull out the cable while holding a connector.

POINT

Forcibly removal the forced stop input cable from the QD74MH will damage the QD74MH or forced stop input cable.

(4) Specifications of forced stop input cable

Generally use the forced stop input cable available as our products. If the required length is not found in our products, fabricate the cable on the customer side. Make the forced stop input cable within 30m(98.43ft.).

(a) Q170DEMICBL□M

1) Model explanation

Type: Q170DEMICBL□M

Symbol	Cable length [m(ft.)]
05	0.5(1.64)
1	1(3.28)
3	3(9.84)
5	5(16.40)
10	10(32.81)
15	15(49.21)
20	20(65.62)
25	25(82.02)
30	30(98.43)

2) Connection diagram

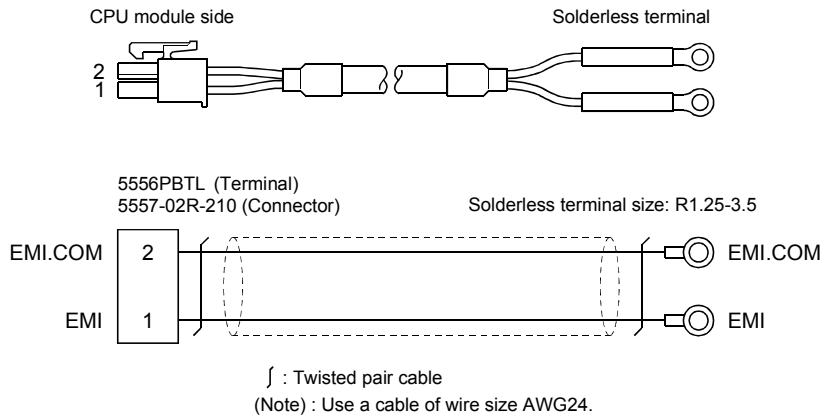

3) Forced stop input connector (Molex Incorporated make)

Type Connector : 5557-02R-210

Terminal : 5556TLPBTL

[Unit: mm (inch)]

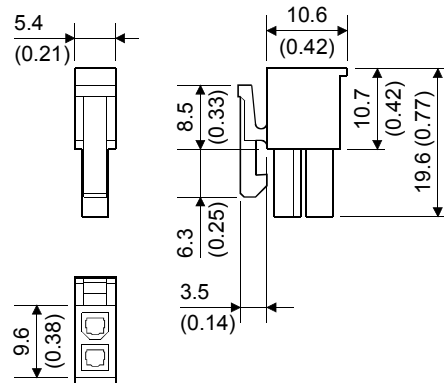

4.3 Confirming the Installation and Wiring

4.3.1 Items to confirm when installation and wiring are completed

Confirm the wiring after installation and wiring.

Confirm the following points in the buffer memory using GX Developer.

- Are the servo amplifiers correctly connected?
- Are the servo amplifiers and servomotors correctly connected?
- Are the external devices (input signals) correctly connected?
- Are the forced stop inputs correctly connected?

Connection with the external devices (input signals) or forced stop inputs can also be confirmed by the following monitor data of GX Developer.

- Connection with the external devices (input signals).... **Md.4** External input signal
- Connection with the forced stop input..... **Md.103** Forced stop input status

Important

If the QD74MH is faulty, or when the required signals such as the proximity dog signal and stop signal are not recognized, unexpected accidents such as "not decelerating at the proximity dog during OPR and colliding with the stopper", or "not being able to stop with the stop signal" may occur.

The "connection confirmation" must be carried out not only when structuring the positioning system, but also when the system has been changed with module replacement or rewiring, etc.

4.4 Start-up

4.4.1 Checklist before trial operation

Table 4.3 Checklists before trial operation

Model name	Confirmation Items	Check	Reference
Main base unit/ Extension base unit	(1) Check that the main base unit has been suited with the CPU module to be used.	<input type="checkbox"/>	Refer to the QCPU User's Manual (Hardware Design, Maintenance and Inspection)
	(2) Check that the model name of module is correct.	<input type="checkbox"/>	
	(3) Check that the installation order is correct.	<input type="checkbox"/>	
	(4) Check that the damage for installed modules.	<input type="checkbox"/>	
	(5) Check that the modules are installed correctly.	<input type="checkbox"/>	
	(6) Check for looseness, rattling or distorted installation.	<input type="checkbox"/>	
	(7) Check that the module fixing screw tightening torque is as specified.	<input type="checkbox"/>	
	(8) Check that the total I/O points of I/O modules and intelligent function modules do not exceed the I/O points of the CPU module.	<input type="checkbox"/>	
Power supply module	(1) Check that the model name of power supply modules is correct.	<input type="checkbox"/>	
	(2) Check that the wire sizes of cables are correct.	<input type="checkbox"/>	
	(3) Check that the power line is wired correctly.	<input type="checkbox"/>	
	(4) Check that FG and LG are wired correctly.	<input type="checkbox"/>	
	(5) Check that the terminal screws are tightened correctly.	<input type="checkbox"/>	
	(6) Check that the terminal screws are tightening torque is as specified.	<input type="checkbox"/>	
	(7) Check that the 100VAC, 200VAC and 24VDC wires are twisted as closely as possible respectively and run in the shortest distance.	<input type="checkbox"/>	
	(8) Check that the 100VAC, 200VAC and 24VDC wires are not bind the cable together with and run close to the power wires.	<input type="checkbox"/>	
	(9) Check that grounding of the earth terminal FG and LG.	<input type="checkbox"/>	
PLC CPU module	(1) Check that the model name of PLC CPU modules is correct.	<input type="checkbox"/>	2.2
	(2) Check that the modules are installed to CPU slot or I/O slot 0 to 2 of the main base unit.	<input type="checkbox"/>	Refer to the QCPU User's Manual (Hardware Design, Maintenance and Inspection)
QD74MH Positioning module	(1) Check that the module fixing screws are tightened correctly.	<input type="checkbox"/>	3.2
	(2) Check that the connection with servo amplifier is correct.	<input type="checkbox"/>	
	(3) Check that the forced stop input is wired correctly.	<input type="checkbox"/>	
I/O module	(1) Check that the wire size of cable is correct.	<input type="checkbox"/>	Refer to the I/O Module Type Building Block User's Manual
	(2) Check that the terminal block screws are tightened correctly.	<input type="checkbox"/>	
	(3) Check that the cables connected to each terminal of terminal block correspond to the signal names.	<input type="checkbox"/>	
	(4) Check that the external power supply are connected correctly. (24VDC, 5VDC)	<input type="checkbox"/>	Refer to the QCPU User's Manual (Hardware Design, Maintenance and Inspection)
	(5) Check that the 100VAC, 200VAC and 24VDC wires are twisted as closely as possible respectively and run in the shortest distance.	<input type="checkbox"/>	
	(6) Check that the 100VAC, 200VAC and 24VDC wires are not bind the cable together with and run close to the I/O wires.	<input type="checkbox"/>	
	(7) Check that the I/O wires are wired correctly.	<input type="checkbox"/>	
SSCNETIII cable	(1) Check that the model name of SSCNETIII cables is correct.	<input type="checkbox"/>	4.2.1
	(2) Check that the connecting position for connector of SSCNETIII cables are correct.		
	(3) Check that the SSCNETIII cables are connected correctly.		
	(4) Check for looseness, rattling or distorted connection.		
	(5) Check that the minimum bend radius or more secured.		
	(6) Check that the MRJ3BUS□M and MRJ3BUS□M-A do not come in contact with wires/cables that use materials where the plasticizing material is contained.		

4.4.2 Trial operation and adjustment procedure

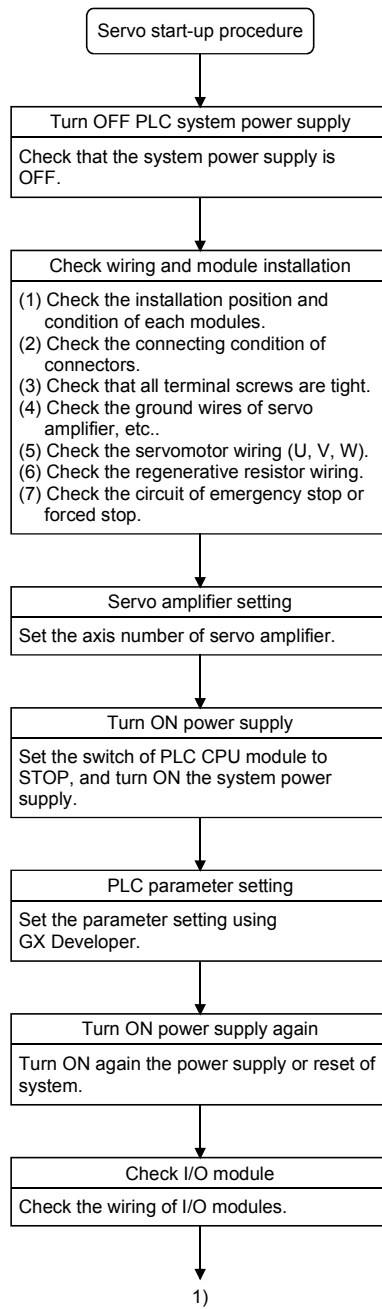

----- Refer to the QCPU User's Manual (Hardware Design, Maintenance and Inspection) for installation of module.

⚠ DANGER

- Be sure to ground the controllers, servo amplifiers and servomotors. (Ground resistance: 100Ω or less) Do not ground commonly with other devices.

⚠ CAUTION

- Check that the combination of modules is correct. Wrong combination may damage the modules.

----- Refer to Section 4.2.1

⚠ CAUTION

- When using a regenerative resistor, shut the power OFF with an error signal. The regenerative resistor may abnormally overheat due to a fault in the regenerative transistor, etc., and may lead to fires.
- Always take heat measure such as flame proofing for the inside of the control panel where the servo amplifier or regenerative resistor is mounted and for the wires used. Failing to do so may lead to fires.

⚠ CAUTION

- Do not mount a phase advancing capacitor, surge absorber or radio noise filter (option FR-BIF) on the output side of the servo amplifier.
- Correctly connect the output side (terminal U, V, W). Incorrect connections will lead the servomotor to operate abnormally.

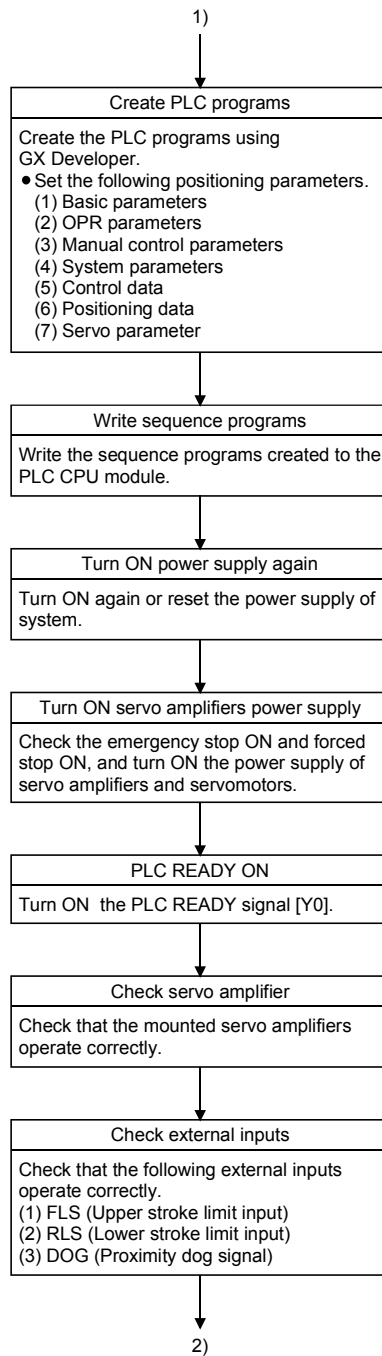

CAUTION

- Set parameter values to those that are compatible with the controller, servo amplifier, servomotor and regenerative resistor model name and the system name application. The protective functions may not function if the settings are incorrect.

DANGER

- Never open the front case or terminal cover at times other than wiring work or periodic inspections even if the power is OFF. The insides of the controller and servo amplifier are charged and may lead to electric shocks.
- When performing wiring work or inspections, turn the power OFF, wait at least ten minutes, and then check the voltage with a tester, etc.. Failing to do so may lead to electric shocks.
- Wire the units after mounting the controller, servo amplifier and servomotor. Failing to do so may lead to electric shocks or damage.

CAUTION

- Always mount a leakage breaker on the controller and servo amplifier power source.
- Install emergency stop circuit externally so that operation can be stopped immediately and the power shut off.
- Use the program commands for the program with the conditions specified in the instruction manual.
- Some devices used in the program have fixed applications, so use these with the conditions specified in the programming manual.

----- Refer to Section 6.5.1

CAUTION

- If safety standards (ex., robot safety rules, etc.,) apply to the system using the controller, servo amplifier and servomotor, make sure that the safety standards are satisfied.
- Construct a safety circuit externally of the controller or servo amplifier if the abnormal operation of the Motion controller or servo amplifier differ from the safety directive operation in the system.

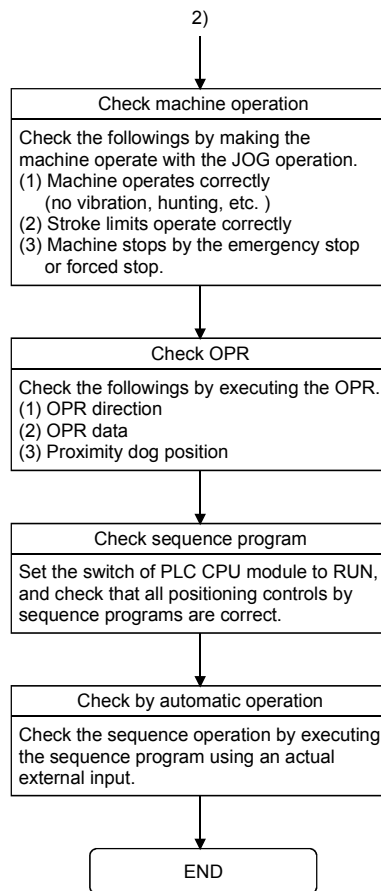

⚠ CAUTION

- The system must have a mechanical allowance so that the machine itself can stop even if the stroke limits switch is passed through at the max. speed.
- Execute the test operation in the system that it is low-speed as much as possible and put forced stop, and confirm the operation and safety.

POINT

- (1) Make note of servomotor module names before the servomotor is mounted on a machine.
 The servomotor name plate may not be visible after the motor is mounted.
- (2) When the servo amplifier, servomotor is first turned on, check the operation before the servomotor is mounted on a machine to avoid an unexpected accidents such as machine breakage.

4.5 Maintenance

4.5.1 Precautions for maintenance

The precautions for servicing are given below. Refer to this section as well as "4.1 Handling Precautions" when carrying out the work.

DANGER

- Completely turn off the externally supplied power used in the system before clearing or tightening the screws. Not doing so could result in electric shock.

CAUTION

- Never try to disassemble or modify module. It may cause product failure, operation failure, injury or fire.
- Completely turn off the externally supplied power used in the system before installation or removing the module. Not doing so could result in electric shock, damage to the module or operation failure.

4.5.2 Disposal instructions

When you discard QD74MH, servo amplifier, a battery (primary battery) and other option articles, please follow the law of each country (area).

CAUTION

- This product is not designed or manufactured to be used in equipment or systems in situations that can affect or endanger human life.
- When considering this product for operation in special applications such as machinery or systems used in passenger transportation, medical, aerospace, atomic power, electric power, or submarine repeating applications, please contact your nearest Mitsubishi sales representative.
- Although this product was manufactured under conditions of strict quality control, you are strongly advised to install safety devices to forestall serious accidents when it is used in facilities where a breakdown in the product is likely to cause a serious accident.

4.6 Daily Inspection

The items that must be inspected daily are shown below.

Table 4.4 Daily inspection

Item	Inspection item		Inspection	Criterion	Action
1	Mounting of base unit		Check that the fixing screws are not loose and the cover is not dislocated.	The screws and cover must be mounted securely.	Retighten the screws.
2	Installation of I/O module		Check that the module is not dislocated and the unit fixing hook is engaged securely.	The module fixing hook must be engaged and installed correctly.	Securely engaged the module fixing hook.
3	Connecting conditions		Check for loose terminal screws.	Screws should not be loose.	Retighten the terminal screws.
			Check for distance between solderless terminals.	The proper clearance should be provided between solderless terminals.	Correct.
			Check the connector part of the cable.	Connections should not be loose.	Retighten the connector fixing screws.
4	Module indication LED	Power supply module	[POWER] LED Check that the LED is ON.	The LED must be ON (green). (Abnormal if the LED is OFF or ON (red)).	Refer to the "QCPU User's Manual (Function Explanation, Program Fundamentals)".
		PLC CPU module	[MODE] LED Check that the LED is ON.	The LED must be ON (green). (Abnormal if the LED is OFF or flickering.)	
			[RUN] LED Check that the LED is ON in RUN status.	The LED must be ON. (Abnormal if the LED is OFF.)	
			[ERR.] LED Check that the LED is OFF.	The LED must be OFF. (Abnormal if the LED is ON or flickering.)	
			[BAT.] LED Check that the LED is OFF.	The LED must be OFF. (Abnormal if the LED is ON.)	
		QD74MH Positioning module	[RUN] LED Check that the LED is ON.	The LED must be ON. (Abnormal if the LED is OFF.)	Refer to Section 2.4
			[ERR.] LED Check that the LED is OFF.	The LED must be OFF. (Abnormal if the LED is ON or flickering.)	
		I/O module	Input LED Check that the LED is ON/OFF.	The LED must be ON when the input power is turned ON. The LED must be OFF when the input power is turned OFF. (Abnormal if the LED does not turn ON or turn OFF as indicated above.)	Refer to "I/O Module Type Building Block User's Manual".
			Output LED Check that the LED is ON/OFF.	The LED must be ON when the input power is turned ON. The LED must be OFF when the input power is turned OFF. (Abnormal if the LED does not turn ON or turn OFF as indicated above.)	

4.7 Periodic Inspection

The items that must be inspected one or two times every 6 months to 1 year are listed below. When the equipment is moved or modified, or layout of the wiring is changed, also implement this inspection.

Table 4.5 Periodic inspection

Item	Inspection item	Inspection	Judgment criteria	Remedy	
1	Ambient environment	Measure with a thermometer and a hygrometer. Measure corrosive gas.	0 to 55 °C (32 to 131 °F)	When the controller is used in the board, the ambient temperature in the board becomes the ambient temperature.	
	Ambient humidity		5 to 95 % RH		
	Atmosphere		No corrosive gases		
2	Power voltage	Measure a voltage across the terminals of 100/200VAC and 24VDC.	85 to 132VAC 170 to 264VAC 15.6 to 31.2VDC	Change the power supply.	
3	Installation	Looseness, rattling Adhesion of dirt and foreign matter	Move the module to check for looseness and rattling.	The module must be installed solidly.	Retighten the screws. If the CPU, I/O, or power supply module is loose, fix it with screws.
			Check visually.	Dirt and foreign matter must not be present.	Remove and clean.
4	Connection	Looseness of terminal screws Proximity of solderless terminals to each other Looseness of connectors	Try to further tighten screws with a screwdriver.	Screws must not be loose.	Retighten the terminal screws.
			Check visually.	Solderless terminals must be positioned at proper intervals.	Correct.
			Check visually.	Connectors must not be loose.	Retighten the connector fixing screws.

5. SPECIFICATIONS AND FUNCTIONS

This section describes the input/output signals with PLC CPU and functions.

5.1 Specifications of Input/Output Signals

5.1.1 List of input/output signals

The QD74MH uses 32 input points and 32 output points for exchanging data with the PLC CPU.

The input/output signals when the QD74MH is mounted in slot No. 0 of the main base unit are shown below.

Device X refers to the signals input from the QD74MH to the PLC CPU, and device Y refers to the signals output from the PLC CPU to the QD74MH.

Signal direction: QD74MH → PLC CPU		Signal direction: PLC CPU → QD74MH			
Device No.	Signal name	Device No.	Signal name		
X0	Unit READY	Y0	PLC READY		
X1	Error detection	Y1	All axis servo ON		
X2	Warning detection	Y2	Forced stop input		
X3	Synchronization flag	Y3	Unusable		
X4	Unusable	Y4			
X5		Y5			
X6		Y6			
X7		Y7			
X8		Y8			
X9		Y9			
XA		YA			
XB		YB			
XC		YC			
XD		YD			
XE		YE			
XF		YF			
X10		Axis 1		Y10	Axis 1
X11		Axis 2		Y11	Axis 2
X12		Axis 3		Y12	Axis 3
X13		Axis 4	Y13	Axis 4	
X14	Axis 5	Y14	Axis 5		
X15	Axis 6	Y15	Axis 6		
X16	Axis 7	Y16	Axis 7		
X17	Axis 8	Y17	Axis 8		
X18	Axis 9	Y18	Axis 9		
X19	Axis 10	Y19	Axis 10		
X1A	Axis 11	Y1A	Axis 11		
X1B	Axis 12	Y1B	Axis 12		
X1C	Axis 13	Y1C	Axis 13		
X1D	Axis 14	Y1D	Axis 14		
X1E	Axis 15	Y1E	Axis 15		
X1F	Axis 16	Y1F	Axis 16		

5

5.1.2 Input signals (QD74MH → PLC CPU)

Device No.	Signal name		Details
X0	Unit READY		<ul style="list-style-type: none"> • When the PLC READY signal [Y0] turns from OFF to ON, the parameter setting range is checked. If no error is found, this signal turns ON. • It turns OFF when the PLC READY signal [Y0] turns OFF. • It turns OFF when the watch dog timer error occurs. • It is used for interlock in a sequence program, etc.
X1	Error detection		<ul style="list-style-type: none"> • This signal turns ON when the error occurs by any axis of from Axis 1 to 16. • It turns OFF by error reset of all axes in which the error occurred. (Confirm the axis error status in "[Md.100] Axis error status".) <p>POINT Start of positioning, OPR or manual control cannot be executed for the axis in operation error occurrence. Start after reset errors.</p>
X2	Warning detection		<ul style="list-style-type: none"> • This signal turns ON when the error occurs by any axis of from Axis 1 to 16. • It turns OFF by warning release of all axes in which the warning occurred. (Confirm the axis warning status in "[Md.101] Axis warning status".) • Warnings of servo amplifier are automatically released by warning release on the servo amplifier side also on the QD74MH side. Therefore, warnings are not released by error reset for an axis.
X3	Synchronization flag		<ul style="list-style-type: none"> • When "Asynchronous" is selected in the module synchronization setting of the CPU module, this signal can be used as interlock for the access from a sequence program to the QD74MH. (After the system power supply ON or reset, this signal turns ON if the access from the PLC CPU to the QD74MH is possible.)
X10	Axis 1	BUSY (Note-1)	<ul style="list-style-type: none"> • This signal turns ON at the start of positioning, OPR and manual control. • It turns OFF at passage of "[Da.8] Dwell time" after positioning stops, OPR completion and manual control completion. • It turns OFF at error completion or positioning stop.
X11	Axis 2		
X12	Axis 3		
X13	Axis 4		
X14	Axis 5		
X15	Axis 6		
X16	Axis 7		
X17	Axis 8		
X18	Axis 9		
X19	Axis 10		
X1A	Axis 11		
X1B	Axis 12		
X1C	Axis 13		
X1D	Axis 14		
X1E	Axis 15		
X1F	Axis 16		

POINT

(Note-1): The BUSY signal turns ON even when position control of movement amount 0 is executed. However, since the ON time is short, the ON status may not to be detected in the sequence program.

5.1.3 Output signals (PLC CPU → QD74MH)

Device No.	Signal name		Details
Y0	PLC READY		<p>(a) This signal notifies the QD74MH that the PLC CPU is normal.</p> <ul style="list-style-type: none"> • It is turned ON/OFF with the sequence program. <p>(b) This signal turns OFF at the change of the basic parameters or OPR parameters.</p> <p>(c) The following processes are executed at the PLC READY signal ON.</p> <ul style="list-style-type: none"> • The setting range check of the basic parameters, OPR parameters and system parameters. • Unit READY signal [X0] ON <p>(d) The following processes are executed at the PLC READY signal from ON to OFF.</p> <ul style="list-style-type: none"> • Unit READY signal [X0] OFF • Sudden stop of operating axis.
Y1	All axis servo ON		<p>ON : Servo ON OFF : Servo OFF</p> <ul style="list-style-type: none"> • The servo ON/OFF is executed for all servo amplifiers connected to the QD74MH. ([READY ON, Servo ON] / [READY OFF, Servo OFF])
Y2	Forced stop input		<p>ON : Requested OFF : Not requested</p> <ul style="list-style-type: none"> • The forced stop is requested from the PLC CPU to the QD74MH.
Y10	Axis 1	Positioning start	<p>ON : Requested OFF : Not requested</p> <ul style="list-style-type: none"> • Positioning, OPR and new current change is started. • The positioning start signal becomes valid at the leading edge, and the operation is started.
Y11	Axis 2		
Y12	Axis 3		
Y13	Axis 4		
Y14	Axis 5		
Y15	Axis 6		
Y16	Axis 7		
Y17	Axis 8		
Y18	Axis 9		
Y19	Axis 10		
Y1A	Axis 11		
Y1B	Axis 12		
Y1C	Axis 13		
Y1D	Axis 14		
Y1E	Axis 15		
Y1F	Axis 16		

5.2 Functions

5.2.1 QD74MH control functions

(1) OPR control

"OPR control" is a function that established the start point for carrying out positioning control, and carries out positioning toward that start point. This is used to return a workpiece, located at a position other than the OP when the power is turned ON or after positioning stop, to the OP. The OPR control is preregistered in the QD74MH as the "Positioning start data No. 9000 (OPR)". (Refer to Chapter 7 "OPR Control".)

(2) Major positioning control

This control is carried out using the positioning data stored in the QD74MH. Positioning control is executed by setting the required items in this positioning data and starting that positioning data. An operation pattern can be set in this positioning data, and with this whether to carry out control with continuous positioning data (ex.: positioning data No.1, No.2, No.3, ...) can be set. (Refer to Chapter 8 "Positioning Control".)

(3) Manual control

Use this manual control to move the workpiece to a random position (JOG operation) and to finely adjust the positioning (incremental feed operation). (Refer to Chapter 9 "Manual Control".)

(4) Sub functions

When executing the above functions, control compensation, limits and functions can be added.

(Refer to Chapter 10 "Function Details".)

5.2.2 Functions of QD74MH

Functions of QD74MH are shown below.

Functions		Details	Reference section
OPR control	<ul style="list-style-type: none"> • Proximity dog type • Data set type • Stopper type • Dog cradle type • Limit switch combined type • Scale origin signal detection type 	This function mechanically establishes the positioning start point using a proximity dog, stopper or limit switch.	Chapter 7
	Positioning control Position control <ul style="list-style-type: none"> • Linear control • 1-axis linear control • 2-axis linear interpolation control • 3-axis linear interpolation control • 4-axis linear interpolation control 	This function executes the positioning to a target position in a linear path by the address or movement amount set in the positioning data.	Chapter 8
Manual control	JOG operation	This function executes the positioning at the specified speed while the JOG start signal is ON.	9.1
	Incremental feed operation	This function executes the positioning corresponding to minute movement amount by manual operation.	9.2
Sub functions	Servo ON/OFF	This function executes the all axes servo ON/OFF or each axis servo ON/OFF.	10.1
	Electronic gear function	This function changes the machine movement amount per commanded pulse by setting of the movement amount per pulse.	10.2
	Hardware stroke limit function	This function executes a deceleration stop with the limit switch input via servo amplifier.	10.3
	Software stroke limit function	If a command outside of the upper/lower limit stroke limit setting range set in the parameters is issued, this function will not execute positioning for that command.	10.4
	Backlash compensation function	This function compensates the mechanical backlash amount. Feed pulses equivalent to the set backlash amount are output each time the movement direction change.	10.5
	Speed limit function	If the command speed exceeds " [Pr.10] Speed limit value" during control, this function limits the commanded speed within the setting range of " [Pr.10] Speed limit value".	10.6
	Acceleration/deceleration control	This function adjusts the acceleration/deceleration for the control.	10.7
	Stop control	This function executes a deceleration stop with the stop command.	10.8
	Sudden stop control	This function executes a sudden stop with the sudden stop command.	10.9
	Forced stop control	This function stops the all axes of servo amplifier by input from DC24V connected to the forced stop input connector of QD74MH or input from PLC CPU.	10.10
	Command in-position function	This function calculates the remaining distance to reach the positioning stop position at the automatic deceleration, if the value is less than the set value, the "Command in-position ([Md.10] Status 2: b1)" signal turns ON.	10.11
	Pausing function	This function pauses a positioning or continues a positioning from the interruption position.	10.12
	Torque limit function	If the torque generated by the servomotor exceeds the torque limit value during control, this function limits the torque generated within the setting range of torque limit value	10.13
	Speed change function	This function changes the speed during positioning operation.	10.14
Acceleration/deceleration time change function	This function changes the acceleration/deceleration time at the speed change.	10.15	

Functions		Details	Reference section
Sub functions	Target position change function	This function changes the target position during positioning operation.	10.16
	Current value change function	This function changes the feed current value to any address.	10.17
	External signal logic selection	This function selects a logic of I/O signals.	10.18
	Operation setting for incompleteness of OPR function	This function selects whether the positioning control is started or not at the incompleteness of OPR.	10.19
	Axis error reset	This function resets the errors occurred.	10.20
	Absolute position system	This function restores the absolute position.	10.21
	Flash ROM write function	This function writes (back-up) the parameter data and positioning data in the flash ROM.	10.22
	Parameter initialization function	This function returns the parameters and positioning data stored in the QD74MH buffer memory and flash ROM to the default values (shipped from the factory).	10.23

6. DATA USED FOR POSITIONING CONTROL

6.1 Memory Configuration and Roles

The QD74MH is equipped with the following two memories for data exchange with PLC CPU and data save.

Table 6.1 Memory configuration

Memory configuration	Role	Area configuration					Backup
		Parameter area	Monitor data area	Control data area	Positioning data area	Servo parameter area	
Buffer memory	This area can be directly accessed with sequence program from PLC CPU, and the parameter data and positioning data can be changed.	○	○	○	○	○	Not possible
Flash ROM	Details of buffer memory required for positioning can be backed up.	○	×	×	○	○	Possible

○: Accessible ×: Not accessible

(1) Details of areas

(a) Parameter area

The parameters, such as basic parameters, OPR parameters, manual control parameters or system parameters required for positioning control can be set and stored.

(b) Monitor data area

The operation state for the common monitor or axis monitor can be stored.

(c) Control data area

The data, for positioning such as common control data or axis control data, and for some sub functions can be set and stored.

(d) Positioning data area

The positioning data No.1 to 32 can be set and stored.

(e) Servo parameter area

The parameters required for positioning control on servo amplifier can be set and stored.

(2) Reading/writing data from buffer memory

Read and write the data from the buffer memory in the following method.

(a) Reading**1) Sequence program**

- 1 word Use FROM instruction or intelligent function device.
- 2 word Use DFRO instruction or intelligent function device.

(b) Writing**1) Sequence program**

- 1 word Use TO instruction or intelligent function device.
- 2 word Use DTO instruction or intelligent function device.

(3) Saving data

Data of the buffer memory cannot be backed up, and the all data are transmitted from FLASH ROM at the system power supply ON or reset of the PLC CPU.

Therefore, back up the data required for positioning using the flash ROM write function.

Refer to Section 10.22 for the flash ROM write function.

6.2 Data Transmission Process

6.2.1 Data transmission process for operation

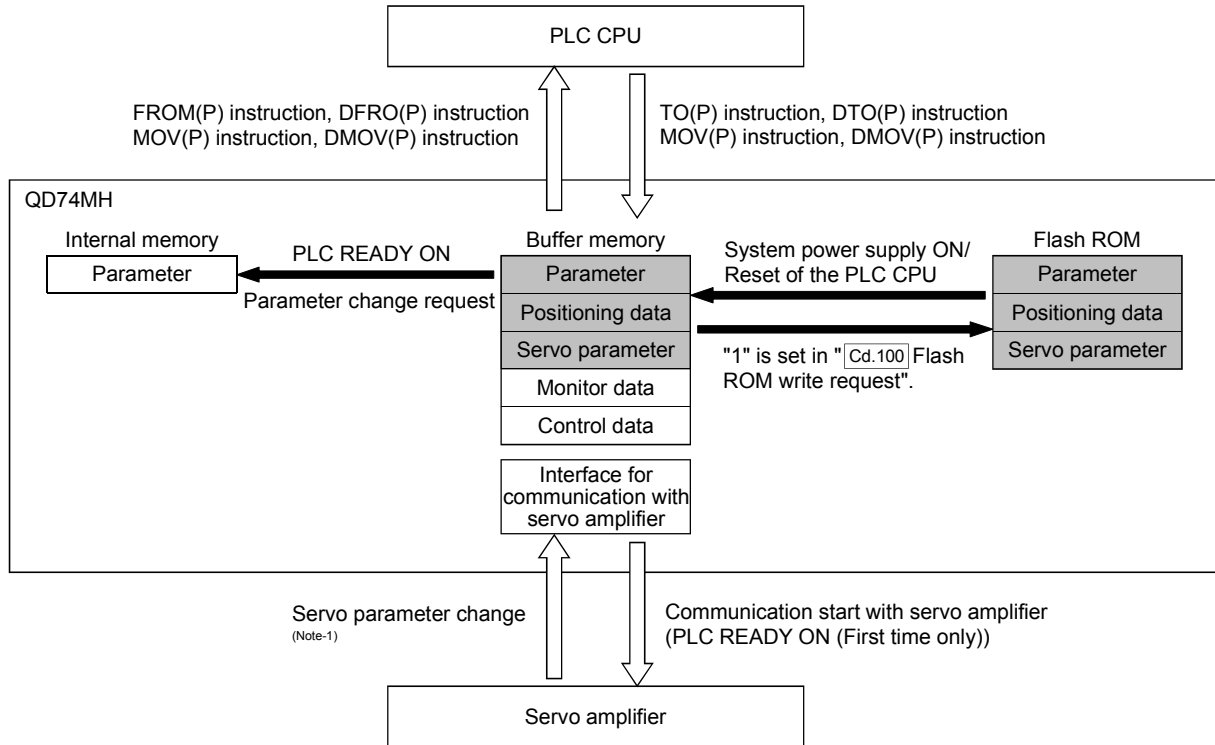

(Note-1): When the parameters are changed by the auto tuning or MR Configurator, the servo parameters are read to the buffer memory of QD74MH.

The data can be transmitted with steps (1) to (6) shown below.

- (1) Transmitting data when power is turned ON or PLC CPU is reset
 - (a) Data stored (backed up) in the flash ROM can be transmitted to the buffer memory. (Refer to Section 10.22)

POINT
Communication with servo amplifier cannot be executed at the system power supply ON. (The servo parameter can be transmitted from the flash ROM to the buffer memory at the system power supply ON, however, they can not be transmitted to the servo amplifiers.) Communication starts with servo amplifier at the PLC READY ON (first time only).

- (2) Transmitting data with command from PLC CPU
 - The parameters or control data can be written from the PLC CPU to the buffer memory using the commands (TO(P) instruction, DTO(P) instruction, MOV(P) instruction or DMOV(P) instruction).

(3) PLC READY ON

- (a) The buffer memory data of QD74MH can be taken to the internal memory. (Refer to Section 6.4 for the parameters taken at the PLC READY ON.)
- (b) The communication starts with servo amplifiers at the PLC READY ON (first time only) after the system power supply ON, and the servo parameters to the buffer memory can be transmitted from QD74MH to the servo amplifier.

POINT

If the backup of parameters in the flash ROM is unnecessary, set the parameters required to the buffer memory of QD74MH with the sequence program before the PLC READY ON after the system power supply ON.

(4) Accessing with command from PLC CPU

The data can be read from the buffer memory to the PLC CPU using the commands (FROM(P) instruction, DFRO(P) instruction, MOV(P) instruction or DMOV(P) instruction).

(5) Reading the servo parameter from the servo amplifier

When the parameters can be changed by the auto tuning etc. of servo amplifier, the servo parameters can be read automatically from the servo amplifier to the buffer memory.

Make the writing operation to the flash ROM to write the servo parameters to the flash ROM. (Refer to Section 10.22.)

(6) Writing the flash ROM by PLC CPU request

The data can be backed up from the buffer memory to the flash ROM by setting to "1" in "Cd.100 Flash ROM write request".

6.2.2 Setting of servo amplifier series

Up to 8 axes servo amplifiers in QD74MH8 and up to 16 axes servo amplifiers in QD74MH16 can be connected. Set the servo amplifier series in the servo parameter for each axis.

Table 6.2 Setting of servo amplifier series

Symbol	Item	Setting range	Details
Pr.300	Servo amplifier series	0: None 1: MR-J3-B 3: MR-J3-B (Fully closed loop control) 4: MR-J3-B (Linear)	Set the servo amplifiers connected to QD74MH.

Communication with servo amplifiers is possible setting by the servo amplifier series. The procedure to communicate with servo amplifiers is shown below.

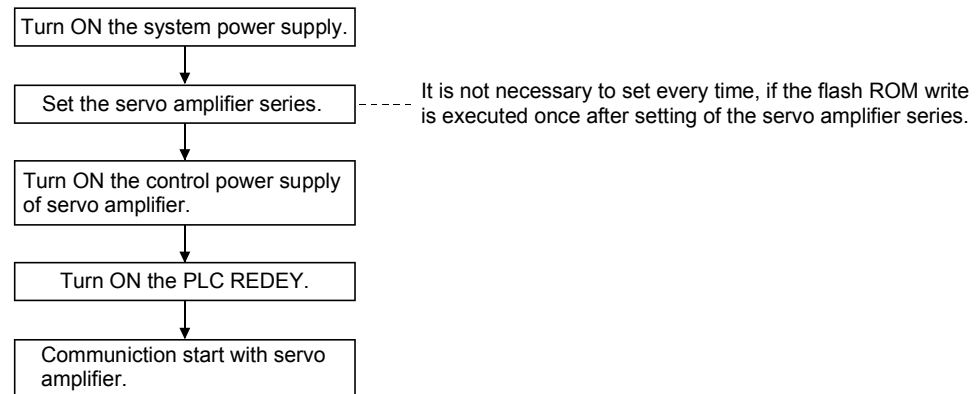
**POINT**

- (1) The communicate with servo amplifiers can be executed at the first PLC READY ON after the system power supply ON. An error code 400 will occur and the unit READY does not turn ON in the following cases.
 - The servo amplifiers corresponding to servo amplifier series cannot be connected.
 - The power supply of servo amplifiers are OFF.
 The communication does not start and the error reset cannot be executed, even if the power supply of servo amplifier is turned ON. Turn the PLC READY ON after the power supply ON for all axes.
- (2) The communication continues even if the PLC READY is turned OFF after communication start with the servo amplifiers.
- (3) The servo amplifier series cannot be changed after the PLC READY ON. Set it before PLC READY ON in the following procedure.
 - Write the data to the flash ROM beforehand.
 - Set the servo amplifier series before the PLC READY ON, after turning ON/OFF of the system power supply or reset of the PLC CPU.
- (4) If the power supply of the servo amplifier is turned OFF after communication start with the servo amplifiers, an error code 400 will occur, and the unit READY turns OFF. The communication does not start and the error reset cannot be executed, even if the power supply of servo amplifier is turned ON.

6.2.3 Exchange of the servo parameters

This section describes the exchange of the servo parameters.

(1) Writing the servo parameters from QD74MH to servo amplifier

Some servo parameters become valid by turning OFF/ON of the power supply of the servo amplifiers. (Refer to Section 6.8.)

Change procedure is shown below.

- 1) Change the servo parameters and write them to the buffer memory.
- 2) Execute the flash ROM write.
- 3) (Change the parameters after procedure 3), if not required.)
- 4) Turn the power supply ON of the servo amplifiers.
- 5) Turn the PLC READY ON. (The parameters changed can be transmitted to the servo amplifiers.)
- 6) Turn the power supply OFF of the system and the servo amplifiers.
- 7) Turn the power supply ON of the system and the servo amplifiers.
(The parameters changed become valid.)
- 8) Turn the PLC READY ON.

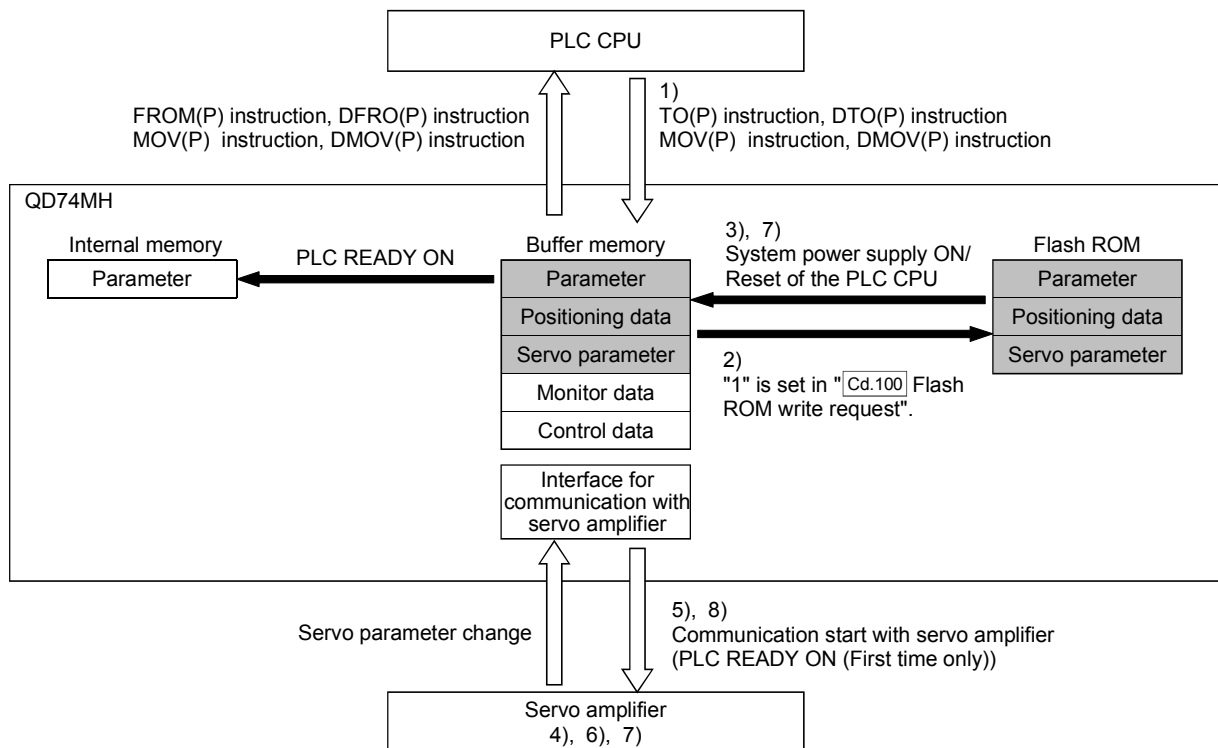

(2) Transmitting the servo parameters from servo amplifier to buffer memory of QD74MH

The parameters changed in the servo amplifier can be automatically transmitted to the buffer memory of QD74MH. However, they cannot be transmitted to the flash ROM of QD74MH. Since the contents changed is lost by turning OFF of the system power supply or reset of the PLC CPU, execute the flash ROM write, if required.

There is a limitation in the write count to the flash ROM. (Refer to Section 10.22.)

Transmitting procedure is shown below.

- 1) The parameters can be changed by MR Configurator or the parameters, such as gain by auto tuning.
- 2) The servo parameters changed in procedure 1) can be automatically transmitted to the buffer memory of QD74MH.
- 3) When "1" is set in the "[Cd.100] Flash ROM write request" in the sequence program, the buffer memory data can be transmitted to the flash ROM.

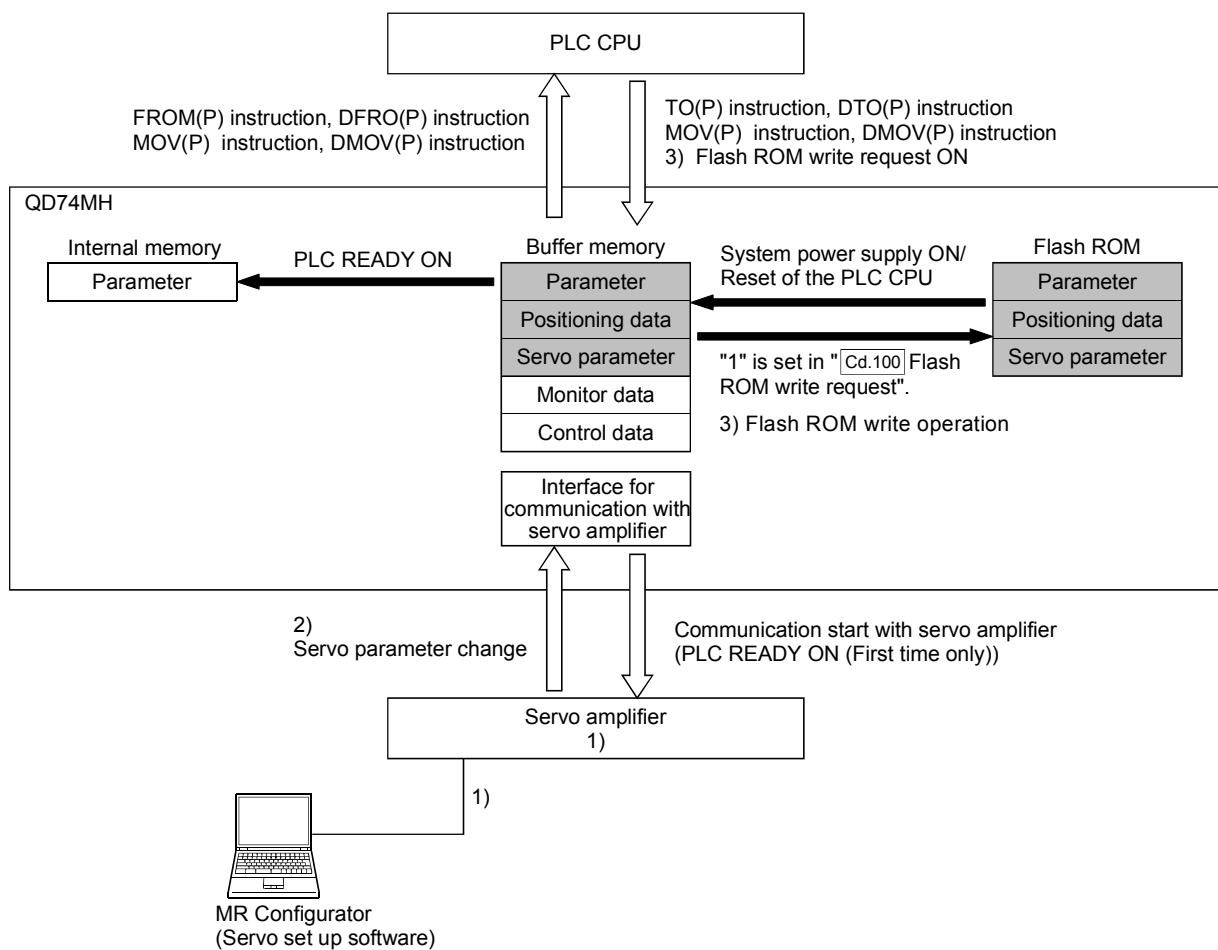

6.3 Buffer Memory Configuration

This section describes the configuration and contents of the buffer memory.

Table 6.3 List of buffer memory

Buffer memory area configuration		Buffer memory address				
		Axis 1	Axis 2	to	Axis 15	Axis 16
Parameter area	Basic parameter	0 to 49	100 to 149	to	1400 to 1449	1500 to 1549
	OPR parameter	50 to 79	150 to 179		1450 to 1479	1550 to 1579
	Manual control parameter	80 to 99	180 to 199		1480 to 1499	1580 to 1599
	System parameter	1600 to 1699				
Monitor data area	Axis monitor data	1700 to 1799	1800 to 1899	to	3100 to 3199	3200 to 3299
	System monitor data	3300 to 3399				
Control data area	Axis control data	3400 to 3499	3500 to 3599	to	4800 to 4899	4900 to 4999
	System control data	5000 to 5099				
Positioning data area	Positioning data (32 data/axis)	5100 to 5419	5420 to 5739	to	9580 to 9899	9900 to 10219
Unusable		10220 to 1299				
Servo parameter area	Servo parameter	10300 to 10599	10600 to 10899	to	14500 to 14799	14800 to 15099
Unusable		15100 to 32767				

POINT
The range of axis No.1 to 8 is valid for the QD74MH8.

REMARK

In the buffer memory address, "n" in "0+100n", etc. indicates a value corresponding to axis No. such as the following tables.

Axis No.	n	Axis No.	n
1	0	9	8
2	1	10	9
3	2	11	10
4	3	12	11
5	4	13	12
6	5	14	13
7	6	15	14
8	7	16	15

- Calculate as follows for the buffer memory address corresponding to each axis.
(Example) For axis 16
 $50+100n$ (Pr.50 OPR method) = $50+100 \times 15=1550$
 $3415+100n$ (Cd.15 Speed change request) = $3415+100 \times 15=4915$
- The range (n=0 to 7) of axis No.1 to 8 is valid for the QD74MH8.

(1) List of basic parameter

Axis No.	Buffer memory address	Parameter item																																																																																															
1	0 to 49																																																																																																
2	100 to 149																																																																																																
3	200 to 249																																																																																																
4	300 to 349																																																																																																
5	400 to 449																																																																																																
6	500 to 549																																																																																																
7	600 to 649																																																																																																
8	700 to 749																																																																																																
9	800 to 849																																																																																																
10	900 to 949																																																																																																
11	1000 to 1049																																																																																																
12	1100 to 1149																																																																																																
13	1200 to 1249																																																																																																
14	1300 to 1349																																																																																																
15	1400 to 1449																																																																																																
16	1500 to 1549																																																																																																
		<table border="1"> <thead> <tr> <th></th> <th>Symbol</th> <th>Parameter item</th> </tr> </thead> <tbody> <tr> <td>0</td> <td rowspan="2">Pr.0</td> <td rowspan="2">Electronic gear numerator (AP)</td> </tr> <tr> <td>1</td> </tr> <tr> <td>2</td> <td rowspan="2">Pr.2</td> <td rowspan="2">Electronic gear denominator (AL)</td> </tr> <tr> <td>3</td> </tr> <tr> <td>4</td> <td rowspan="2">Pr.4</td> <td rowspan="2">Software stroke limit upper limit value</td> </tr> <tr> <td>5</td> </tr> <tr> <td>6</td> <td rowspan="2">Pr.6</td> <td rowspan="2">Software stroke limit lower limit value</td> </tr> <tr> <td>7</td> </tr> <tr> <td>8</td> <td>Pr.8</td> <td>Backlash compensation amount</td> </tr> <tr> <td>9</td> <td>—</td> <td>Unusable</td> </tr> <tr> <td>10</td> <td rowspan="2">Pr.10</td> <td rowspan="2">Speed limit value</td> </tr> <tr> <td>11</td> </tr> <tr> <td>12</td> <td rowspan="3">—</td> <td rowspan="3">Unusable</td> </tr> <tr> <td>13</td> </tr> <tr> <td>14</td> </tr> <tr> <td>15</td> <td>Pr.15</td> <td>Acceleration/deceleration method</td> </tr> <tr> <td>16</td> <td>Pr.16</td> <td>S-curve acceleration/deceleration time constant</td> </tr> <tr> <td>17</td> <td>Pr.17</td> <td>Sudden stop deceleration time</td> </tr> <tr> <td>18</td> <td rowspan="2">—</td> <td rowspan="2">Unusable</td> </tr> <tr> <td>19</td> </tr> <tr> <td>20</td> <td rowspan="2">Pr.20</td> <td rowspan="2">Command in-position range</td> </tr> <tr> <td>21</td> </tr> <tr> <td>22</td> <td>—</td> <td>Unusable</td> </tr> <tr> <td>23</td> <td>Pr.23</td> <td>Target position change overrun processing selection</td> </tr> <tr> <td>24</td> <td>—</td> <td>Unusable</td> </tr> <tr> <td>25</td> <td>Pr.25</td> <td>Interpolation group</td> </tr> <tr> <td>26</td> <td rowspan="2">Pr.26</td> <td rowspan="2">Linear interpolation speed limit value</td> </tr> <tr> <td>27</td> </tr> <tr> <td>28</td> <td rowspan="3">—</td> <td rowspan="3">Unusable</td> </tr> <tr> <td>29</td> </tr> <tr> <td>30</td> </tr> <tr> <td>31</td> <td>Pr.31</td> <td>External input signal logic selection</td> </tr> <tr> <td>32</td> <td rowspan="18">—</td> <td rowspan="18">Unusable</td> </tr> <tr> <td>33</td> </tr> <tr> <td>34</td> </tr> <tr> <td>35</td> </tr> <tr> <td>36</td> </tr> <tr> <td>37</td> </tr> <tr> <td>38</td> </tr> <tr> <td>39</td> </tr> <tr> <td>40</td> </tr> <tr> <td>41</td> </tr> <tr> <td>42</td> </tr> <tr> <td>43</td> </tr> <tr> <td>44</td> </tr> <tr> <td>45</td> </tr> <tr> <td>46</td> </tr> <tr> <td>47</td> </tr> <tr> <td>48</td> </tr> <tr> <td>49</td> </tr> </tbody> </table>		Symbol	Parameter item	0	Pr.0	Electronic gear numerator (AP)	1	2	Pr.2	Electronic gear denominator (AL)	3	4	Pr.4	Software stroke limit upper limit value	5	6	Pr.6	Software stroke limit lower limit value	7	8	Pr.8	Backlash compensation amount	9	—	Unusable	10	Pr.10	Speed limit value	11	12	—	Unusable	13	14	15	Pr.15	Acceleration/deceleration method	16	Pr.16	S-curve acceleration/deceleration time constant	17	Pr.17	Sudden stop deceleration time	18	—	Unusable	19	20	Pr.20	Command in-position range	21	22	—	Unusable	23	Pr.23	Target position change overrun processing selection	24	—	Unusable	25	Pr.25	Interpolation group	26	Pr.26	Linear interpolation speed limit value	27	28	—	Unusable	29	30	31	Pr.31	External input signal logic selection	32	—	Unusable	33	34	35	36	37	38	39	40	41	42	43	44	45	46	47	48	49
	Symbol	Parameter item																																																																																															
0	Pr.0	Electronic gear numerator (AP)																																																																																															
1																																																																																																	
2	Pr.2	Electronic gear denominator (AL)																																																																																															
3																																																																																																	
4	Pr.4	Software stroke limit upper limit value																																																																																															
5																																																																																																	
6	Pr.6	Software stroke limit lower limit value																																																																																															
7																																																																																																	
8	Pr.8	Backlash compensation amount																																																																																															
9	—	Unusable																																																																																															
10	Pr.10	Speed limit value																																																																																															
11																																																																																																	
12	—	Unusable																																																																																															
13																																																																																																	
14																																																																																																	
15	Pr.15	Acceleration/deceleration method																																																																																															
16	Pr.16	S-curve acceleration/deceleration time constant																																																																																															
17	Pr.17	Sudden stop deceleration time																																																																																															
18	—	Unusable																																																																																															
19																																																																																																	
20	Pr.20	Command in-position range																																																																																															
21																																																																																																	
22	—	Unusable																																																																																															
23	Pr.23	Target position change overrun processing selection																																																																																															
24	—	Unusable																																																																																															
25	Pr.25	Interpolation group																																																																																															
26	Pr.26	Linear interpolation speed limit value																																																																																															
27																																																																																																	
28	—	Unusable																																																																																															
29																																																																																																	
30																																																																																																	
31	Pr.31	External input signal logic selection																																																																																															
32	—	Unusable																																																																																															
33																																																																																																	
34																																																																																																	
35																																																																																																	
36																																																																																																	
37																																																																																																	
38																																																																																																	
39																																																																																																	
40																																																																																																	
41																																																																																																	
42																																																																																																	
43																																																																																																	
44																																																																																																	
45																																																																																																	
46																																																																																																	
47																																																																																																	
48																																																																																																	
49																																																																																																	

(2) List of OPR parameter

Axis No.	Buffer memory address	Parameter item																																																											
1	50 to 79	<table border="1"> <thead> <tr> <th></th> <th>Symbol</th> <th>Parameter item</th> </tr> </thead> <tbody> <tr> <td>0</td> <td>Pr.50</td> <td>OPR method</td> </tr> <tr> <td>1</td> <td>Pr.51</td> <td>OPR direction</td> </tr> <tr> <td>2</td> <td rowspan="2">Pr.52</td> <td rowspan="2">OP address</td> </tr> <tr> <td>3</td> </tr> <tr> <td>4</td> <td rowspan="2">Pr.54</td> <td rowspan="2">OPR speed</td> </tr> <tr> <td>5</td> </tr> <tr> <td>6</td> <td>Pr.56</td> <td>Creep speed</td> </tr> <tr> <td>7</td> <td>—</td> <td>Unusable</td> </tr> <tr> <td>8</td> <td>Pr.58</td> <td>OPR acceleration time</td> </tr> <tr> <td>9</td> <td>Pr.59</td> <td>OPR deceleration time</td> </tr> <tr> <td>10</td> <td rowspan="2">Pr.60</td> <td rowspan="2">OP shift amount</td> </tr> <tr> <td>11</td> </tr> <tr> <td>12</td> <td rowspan="2">Pr.62</td> <td rowspan="2">OP search limit</td> </tr> <tr> <td>13</td> </tr> <tr> <td>14</td> <td rowspan="2">—</td> <td rowspan="2">Unusable</td> </tr> <tr> <td>15</td> </tr> <tr> <td>16</td> <td>Pr.66</td> <td>Operation setting for incompleteness of OPR</td> </tr> <tr> <td>17</td> <td rowspan="12">—</td> <td rowspan="12">Unusable</td> </tr> <tr> <td>18</td> </tr> <tr> <td>19</td> </tr> <tr> <td>20</td> </tr> <tr> <td>21</td> </tr> <tr> <td>22</td> </tr> <tr> <td>23</td> </tr> <tr> <td>24</td> </tr> <tr> <td>25</td> </tr> <tr> <td>26</td> </tr> <tr> <td>27</td> </tr> <tr> <td>28</td> </tr> <tr> <td>29</td> </tr> </tbody> </table>		Symbol	Parameter item	0	Pr.50	OPR method	1	Pr.51	OPR direction	2	Pr.52	OP address	3	4	Pr.54	OPR speed	5	6	Pr.56	Creep speed	7	—	Unusable	8	Pr.58	OPR acceleration time	9	Pr.59	OPR deceleration time	10	Pr.60	OP shift amount	11	12	Pr.62	OP search limit	13	14	—	Unusable	15	16	Pr.66	Operation setting for incompleteness of OPR	17	—	Unusable	18	19	20	21	22	23	24	25	26	27	28	29
	Symbol		Parameter item																																																										
0	Pr.50		OPR method																																																										
1	Pr.51		OPR direction																																																										
2	Pr.52		OP address																																																										
3																																																													
4	Pr.54		OPR speed																																																										
5																																																													
6	Pr.56		Creep speed																																																										
7	—		Unusable																																																										
8	Pr.58		OPR acceleration time																																																										
9	Pr.59		OPR deceleration time																																																										
10	Pr.60		OP shift amount																																																										
11																																																													
12	Pr.62		OP search limit																																																										
13																																																													
14	—	Unusable																																																											
15																																																													
16	Pr.66	Operation setting for incompleteness of OPR																																																											
17	—	Unusable																																																											
18																																																													
19																																																													
20																																																													
21																																																													
22																																																													
23																																																													
24																																																													
25																																																													
26																																																													
27																																																													
28																																																													
29																																																													
2	150 to 179																																																												
3	250 to 279																																																												
4	350 to 379																																																												
5	450 to 479																																																												
6	550 to 579																																																												
7	650 to 679																																																												
8	750 to 779																																																												
9	850 to 879																																																												
10	950 to 979																																																												
11	1050 to 1079																																																												
12	1150 to 1179																																																												
13	1250 to 1279																																																												
14	1350 to 1379																																																												
15	1450 to 1479																																																												
16	1550 to 1579																																																												

(3) List of manual control parameter

Axis No.	Buffer memory address	Parameter item																																			
1	80 to 99	<table border="1"> <thead> <tr> <th></th> <th>Symbol</th> <th>Parameter item</th> </tr> </thead> <tbody> <tr> <td>0</td> <td rowspan="2">Pr.80</td> <td>JOG speed</td> </tr> <tr> <td>1</td> <td>JOG operation acceleration time</td> </tr> <tr> <td>2</td> <td>Pr.82</td> <td>JOG operation deceleration time</td> </tr> <tr> <td>3</td> <td>Pr.83</td> <td>JOG operation deceleration time</td> </tr> <tr> <td>4</td> <td rowspan="2">Pr.84</td> <td>Incremental feedrate</td> </tr> <tr> <td>5</td> <td></td> </tr> <tr> <td>6</td> <td rowspan="10">—</td> <td rowspan="10">Unusable</td> </tr> <tr> <td>7</td> </tr> <tr> <td>8</td> </tr> <tr> <td>9</td> </tr> <tr> <td>10</td> </tr> <tr> <td>11</td> </tr> <tr> <td>12</td> </tr> <tr> <td>13</td> </tr> <tr> <td>14</td> </tr> <tr> <td>15</td> </tr> <tr> <td>16</td> </tr> <tr> <td>17</td> </tr> <tr> <td>18</td> </tr> <tr> <td>19</td> </tr> </tbody> </table>		Symbol	Parameter item	0	Pr.80	JOG speed	1	JOG operation acceleration time	2	Pr.82	JOG operation deceleration time	3	Pr.83	JOG operation deceleration time	4	Pr.84	Incremental feedrate	5		6	—	Unusable	7	8	9	10	11	12	13	14	15	16	17	18	19
	Symbol		Parameter item																																		
0	Pr.80		JOG speed																																		
1			JOG operation acceleration time																																		
2	Pr.82		JOG operation deceleration time																																		
3	Pr.83		JOG operation deceleration time																																		
4	Pr.84		Incremental feedrate																																		
5																																					
6	—		Unusable																																		
7																																					
8																																					
9																																					
10																																					
11																																					
12																																					
13																																					
14																																					
15																																					
16																																					
17																																					
18																																					
19																																					
2	180 to 199																																				
3	280 to 299																																				
4	380 to 399																																				
5	480 to 499																																				
6	580 to 599																																				
7	680 to 699																																				
8	780 to 799																																				
9	880 to 899																																				
10	980 to 999																																				
11	1080 to 1099																																				
12	1180 to 1199																																				
13	1280 to 1299																																				
14	1380 to 1399																																				
15	1480 to 1499																																				
16	1580 to 1599																																				

(4) List of system parameter

Buffer memory address	Symbol	Parameter item	Buffer memory address	Symbol	Parameter item
1600	—	Unusable	1650		
1601	Pr.101	External forced stop selection	1651		
1602			1652		
1603			1653		
1604			1654		
1605			1655		
1606			1656		
1607			1657		
1608			1658		
1609			1659		
1610			1660		
1611			1661		
1612			1662		
1613			1663		
1614			1664		
1615			1665		
1616			1666		
1617			1667		
1618			1668		
1619			1669		
1620			1670		
1621			1671		
1622			1672		
1623			1673		
1624			1674		
1625	—	Unusable	1675	—	
1626			1676		
1627			1677		
1628			1678		
1629			1679		
1630			1680		
1631			1681		
1632			1682		
1633			1683		
1634			1684		
1635			1685		
1636			1686		
1637			1687		
1638			1688		
1639			1689		
1640			1690		
1641			1691		
1642			1692		
1643			1693		
1644			1694		
1645			1695		
1646			1696		
1647			1697		
1648			1698		
1649			1699		

(5) List of axis monitor data

Axis No.	Buffer memory address	Parameter item																																																																																																																																																																																																																																																																
1	1700 to 1799																																																																																																																																																																																																																																																																	
2	1800 to 1899																																																																																																																																																																																																																																																																	
3	1900 to 1999																																																																																																																																																																																																																																																																	
4	2000 to 2099																																																																																																																																																																																																																																																																	
5	2100 to 2199																																																																																																																																																																																																																																																																	
6	2200 to 2299																																																																																																																																																																																																																																																																	
7	2300 to 2399																																																																																																																																																																																																																																																																	
8	2400 to 2499																																																																																																																																																																																																																																																																	
9	2500 to 2599																																																																																																																																																																																																																																																																	
10	2600 to 2699																																																																																																																																																																																																																																																																	
11	2700 to 2799																																																																																																																																																																																																																																																																	
12	2800 to 2899																																																																																																																																																																																																																																																																	
13	2900 to 2999																																																																																																																																																																																																																																																																	
14	3000 to 3099																																																																																																																																																																																																																																																																	
15	3100 to 3199																																																																																																																																																																																																																																																																	
16	3200 to 3299																																																																																																																																																																																																																																																																	
		<table border="1"> <thead> <tr> <th>Symbol</th> <th>Parameter item</th> </tr> </thead> <tbody> <tr><td>0</td><td>Md.0</td><td>Current feed value</td></tr> <tr><td>1</td><td>Md.2</td><td>Feedrate</td></tr> <tr><td>2</td><td>Md.4</td><td>External input signal</td></tr> <tr><td>3</td><td>Md.5</td><td>Positioning data No. being executed</td></tr> <tr><td>4</td><td>Md.6</td><td>Error code</td></tr> <tr><td>5</td><td>Md.7</td><td>Error details</td></tr> <tr><td>6</td><td>Md.8</td><td>Warning code</td></tr> <tr><td>7</td><td>Md.9</td><td>Status 1</td></tr> <tr><td>8</td><td>Md.10</td><td>Status 2</td></tr> <tr><td>9</td><td></td><td></td></tr> <tr><td>10</td><td></td><td></td></tr> <tr><td>11</td><td></td><td></td></tr> <tr><td>12</td><td></td><td></td></tr> <tr><td>13</td><td></td><td></td></tr> <tr><td>14</td><td></td><td></td></tr> <tr><td>15</td><td></td><td></td></tr> <tr><td>16</td><td></td><td></td></tr> <tr><td>17</td><td></td><td></td></tr> <tr><td>18</td><td>—</td><td>Unusable</td></tr> <tr><td>19</td><td></td><td></td></tr> <tr><td>20</td><td></td><td></td></tr> <tr><td>21</td><td></td><td></td></tr> <tr><td>22</td><td></td><td></td></tr> <tr><td>23</td><td></td><td></td></tr> <tr><td>24</td><td></td><td></td></tr> <tr><td>25</td><td></td><td></td></tr> <tr><td>26</td><td>Md.26</td><td>Real current value</td></tr> <tr><td>27</td><td>Md.28</td><td>Deviation counter value</td></tr> <tr><td>28</td><td></td><td></td></tr> <tr><td>29</td><td></td><td></td></tr> <tr><td>30</td><td>—</td><td>Unusable</td></tr> <tr><td>31</td><td>Md.31</td><td>Motor current value</td></tr> <tr><td>32</td><td>Md.32</td><td>Motor rotation speed</td></tr> <tr><td>33</td><td>Md.34</td><td>Regenerative load ratio</td></tr> <tr><td>34</td><td>Md.35</td><td>Effective load torque ratio</td></tr> <tr><td>35</td><td>Md.36</td><td>Peak torque ratio</td></tr> <tr><td>36</td><td></td><td></td></tr> <tr><td>37</td><td></td><td></td></tr> <tr><td>38</td><td>—</td><td>Unusable</td></tr> <tr><td>39</td><td></td><td></td></tr> <tr><td>40</td><td>Md.40</td><td>Servo status 1</td></tr> <tr><td>41</td><td>Md.41</td><td>Servo status 2</td></tr> <tr><td>42</td><td></td><td></td></tr> <tr><td>43</td><td></td><td></td></tr> <tr><td>44</td><td></td><td></td></tr> <tr><td>45</td><td>—</td><td>Unusable</td></tr> <tr><td>46</td><td></td><td></td></tr> <tr><td>47</td><td></td><td></td></tr> <tr><td>48</td><td></td><td></td></tr> <tr><td>49</td><td></td><td></td></tr> </tbody> </table>	Symbol	Parameter item	0	Md.0	Current feed value	1	Md.2	Feedrate	2	Md.4	External input signal	3	Md.5	Positioning data No. being executed	4	Md.6	Error code	5	Md.7	Error details	6	Md.8	Warning code	7	Md.9	Status 1	8	Md.10	Status 2	9			10			11			12			13			14			15			16			17			18	—	Unusable	19			20			21			22			23			24			25			26	Md.26	Real current value	27	Md.28	Deviation counter value	28			29			30	—	Unusable	31	Md.31	Motor current value	32	Md.32	Motor rotation speed	33	Md.34	Regenerative load ratio	34	Md.35	Effective load torque ratio	35	Md.36	Peak torque ratio	36			37			38	—	Unusable	39			40	Md.40	Servo status 1	41	Md.41	Servo status 2	42			43			44			45	—	Unusable	46			47			48			49			<table border="1"> <thead> <tr> <th>Symbol</th> <th>Parameter item</th> </tr> </thead> <tbody> <tr><td>50</td><td></td></tr> <tr><td>51</td><td></td></tr> <tr><td>52</td><td></td></tr> <tr><td>53</td><td></td></tr> <tr><td>54</td><td></td></tr> <tr><td>55</td><td></td></tr> <tr><td>56</td><td></td></tr> <tr><td>57</td><td></td></tr> <tr><td>58</td><td></td></tr> <tr><td>59</td><td></td></tr> <tr><td>60</td><td></td></tr> <tr><td>61</td><td></td></tr> <tr><td>62</td><td></td></tr> <tr><td>63</td><td></td></tr> <tr><td>64</td><td></td></tr> <tr><td>65</td><td></td></tr> <tr><td>66</td><td></td></tr> <tr><td>67</td><td></td></tr> <tr><td>68</td><td></td></tr> <tr><td>69</td><td></td></tr> <tr><td>70</td><td></td></tr> <tr><td>71</td><td></td></tr> <tr><td>72</td><td></td></tr> <tr><td>73</td><td></td></tr> <tr><td>74</td><td>—</td><td>Unusable</td></tr> <tr><td>75</td><td></td></tr> <tr><td>76</td><td></td></tr> <tr><td>77</td><td></td></tr> <tr><td>78</td><td></td></tr> <tr><td>79</td><td></td></tr> <tr><td>80</td><td></td></tr> <tr><td>81</td><td></td></tr> <tr><td>82</td><td></td></tr> <tr><td>83</td><td></td></tr> <tr><td>84</td><td></td></tr> <tr><td>85</td><td></td></tr> <tr><td>86</td><td></td></tr> <tr><td>87</td><td></td></tr> <tr><td>88</td><td></td></tr> <tr><td>89</td><td></td></tr> <tr><td>90</td><td></td></tr> <tr><td>91</td><td></td></tr> <tr><td>92</td><td></td></tr> <tr><td>93</td><td></td></tr> <tr><td>94</td><td></td></tr> <tr><td>95</td><td></td></tr> <tr><td>96</td><td></td></tr> <tr><td>97</td><td></td></tr> <tr><td>98</td><td></td></tr> <tr><td>99</td><td></td></tr> </tbody> </table>	Symbol	Parameter item	50		51		52		53		54		55		56		57		58		59		60		61		62		63		64		65		66		67		68		69		70		71		72		73		74	—	Unusable	75		76		77		78		79		80		81		82		83		84		85		86		87		88		89		90		91		92		93		94		95		96		97		98		99	
Symbol	Parameter item																																																																																																																																																																																																																																																																	
0	Md.0	Current feed value																																																																																																																																																																																																																																																																
1	Md.2	Feedrate																																																																																																																																																																																																																																																																
2	Md.4	External input signal																																																																																																																																																																																																																																																																
3	Md.5	Positioning data No. being executed																																																																																																																																																																																																																																																																
4	Md.6	Error code																																																																																																																																																																																																																																																																
5	Md.7	Error details																																																																																																																																																																																																																																																																
6	Md.8	Warning code																																																																																																																																																																																																																																																																
7	Md.9	Status 1																																																																																																																																																																																																																																																																
8	Md.10	Status 2																																																																																																																																																																																																																																																																
9																																																																																																																																																																																																																																																																		
10																																																																																																																																																																																																																																																																		
11																																																																																																																																																																																																																																																																		
12																																																																																																																																																																																																																																																																		
13																																																																																																																																																																																																																																																																		
14																																																																																																																																																																																																																																																																		
15																																																																																																																																																																																																																																																																		
16																																																																																																																																																																																																																																																																		
17																																																																																																																																																																																																																																																																		
18	—	Unusable																																																																																																																																																																																																																																																																
19																																																																																																																																																																																																																																																																		
20																																																																																																																																																																																																																																																																		
21																																																																																																																																																																																																																																																																		
22																																																																																																																																																																																																																																																																		
23																																																																																																																																																																																																																																																																		
24																																																																																																																																																																																																																																																																		
25																																																																																																																																																																																																																																																																		
26	Md.26	Real current value																																																																																																																																																																																																																																																																
27	Md.28	Deviation counter value																																																																																																																																																																																																																																																																
28																																																																																																																																																																																																																																																																		
29																																																																																																																																																																																																																																																																		
30	—	Unusable																																																																																																																																																																																																																																																																
31	Md.31	Motor current value																																																																																																																																																																																																																																																																
32	Md.32	Motor rotation speed																																																																																																																																																																																																																																																																
33	Md.34	Regenerative load ratio																																																																																																																																																																																																																																																																
34	Md.35	Effective load torque ratio																																																																																																																																																																																																																																																																
35	Md.36	Peak torque ratio																																																																																																																																																																																																																																																																
36																																																																																																																																																																																																																																																																		
37																																																																																																																																																																																																																																																																		
38	—	Unusable																																																																																																																																																																																																																																																																
39																																																																																																																																																																																																																																																																		
40	Md.40	Servo status 1																																																																																																																																																																																																																																																																
41	Md.41	Servo status 2																																																																																																																																																																																																																																																																
42																																																																																																																																																																																																																																																																		
43																																																																																																																																																																																																																																																																		
44																																																																																																																																																																																																																																																																		
45	—	Unusable																																																																																																																																																																																																																																																																
46																																																																																																																																																																																																																																																																		
47																																																																																																																																																																																																																																																																		
48																																																																																																																																																																																																																																																																		
49																																																																																																																																																																																																																																																																		
Symbol	Parameter item																																																																																																																																																																																																																																																																	
50																																																																																																																																																																																																																																																																		
51																																																																																																																																																																																																																																																																		
52																																																																																																																																																																																																																																																																		
53																																																																																																																																																																																																																																																																		
54																																																																																																																																																																																																																																																																		
55																																																																																																																																																																																																																																																																		
56																																																																																																																																																																																																																																																																		
57																																																																																																																																																																																																																																																																		
58																																																																																																																																																																																																																																																																		
59																																																																																																																																																																																																																																																																		
60																																																																																																																																																																																																																																																																		
61																																																																																																																																																																																																																																																																		
62																																																																																																																																																																																																																																																																		
63																																																																																																																																																																																																																																																																		
64																																																																																																																																																																																																																																																																		
65																																																																																																																																																																																																																																																																		
66																																																																																																																																																																																																																																																																		
67																																																																																																																																																																																																																																																																		
68																																																																																																																																																																																																																																																																		
69																																																																																																																																																																																																																																																																		
70																																																																																																																																																																																																																																																																		
71																																																																																																																																																																																																																																																																		
72																																																																																																																																																																																																																																																																		
73																																																																																																																																																																																																																																																																		
74	—	Unusable																																																																																																																																																																																																																																																																
75																																																																																																																																																																																																																																																																		
76																																																																																																																																																																																																																																																																		
77																																																																																																																																																																																																																																																																		
78																																																																																																																																																																																																																																																																		
79																																																																																																																																																																																																																																																																		
80																																																																																																																																																																																																																																																																		
81																																																																																																																																																																																																																																																																		
82																																																																																																																																																																																																																																																																		
83																																																																																																																																																																																																																																																																		
84																																																																																																																																																																																																																																																																		
85																																																																																																																																																																																																																																																																		
86																																																																																																																																																																																																																																																																		
87																																																																																																																																																																																																																																																																		
88																																																																																																																																																																																																																																																																		
89																																																																																																																																																																																																																																																																		
90																																																																																																																																																																																																																																																																		
91																																																																																																																																																																																																																																																																		
92																																																																																																																																																																																																																																																																		
93																																																																																																																																																																																																																																																																		
94																																																																																																																																																																																																																																																																		
95																																																																																																																																																																																																																																																																		
96																																																																																																																																																																																																																																																																		
97																																																																																																																																																																																																																																																																		
98																																																																																																																																																																																																																																																																		
99																																																																																																																																																																																																																																																																		

(6) List of system monitor data

Buffer memory address	Symbol	Parameter item	Buffer memory address	Symbol	Parameter item
3300	Md.100	Axis error status	3350	—	Unusable
3301	Md.101	Axis warning status	3351		
3302	Md.102	Number of write accesses to flash ROM	3352		
3303	Md.103	Forced stop input status	3353		
3304	—	Unusable	3354		
3305			3355		
3306			3356		
3307			3357		
3308			3358		
3309			3359		
3310			3360		
3311			3361		
3312			3362		
3313			3363		
3314			3364		
3315			3365		
3316			3366		
3317			3367		
3318			3368		
3319			3369		
3320			3370		
3321			3371		
3322			3372		
3323			3373		
3324			3374		
3325			3375		
3326			3376		
3327			3377		
3328			3378		
3329			3379		
3330			3380		
3331			3381		
3332			3382		
3333			3383		
3334			3384		
3335			3385		
3336			3386		
3337	3387				
3338	3388				
3339	3389				
3340	3390				
3341	3391				
3342	3392				
3343	3393				
3344	3394				
3345	3395				
3346	3396				
3347	3397				
3348	3398				
3349	3399				

(7) List of axis control data

Axis No.	Buffer memory address	Parameter item																																																																																																																																																																																																																																																																																																																			
1	3400 to 3499																																																																																																																																																																																																																																																																																																																				
2	3500 to 3599																																																																																																																																																																																																																																																																																																																				
3	3600 to 3699																																																																																																																																																																																																																																																																																																																				
4	3700 to 3799																																																																																																																																																																																																																																																																																																																				
5	3800 to 3899																																																																																																																																																																																																																																																																																																																				
6	3900 to 3999																																																																																																																																																																																																																																																																																																																				
7	4000 to 4099																																																																																																																																																																																																																																																																																																																				
8	4100 to 4199																																																																																																																																																																																																																																																																																																																				
9	4200 to 4299																																																																																																																																																																																																																																																																																																																				
10	4300 to 4399																																																																																																																																																																																																																																																																																																																				
11	4400 to 4499																																																																																																																																																																																																																																																																																																																				
12	4500 to 4599																																																																																																																																																																																																																																																																																																																				
13	4600 to 4699																																																																																																																																																																																																																																																																																																																				
14	4700 to 4799																																																																																																																																																																																																																																																																																																																				
15	4800 to 4899																																																																																																																																																																																																																																																																																																																				
16	4900 to 4999																																																																																																																																																																																																																																																																																																																				
		<table border="1"> <thead> <tr> <th></th> <th>Symbol</th> <th>Parameter item</th> </tr> </thead> <tbody> <tr><td>0</td><td>Cd.0</td><td>Axis error reset</td></tr> <tr><td>1</td><td>Cd.1</td><td>Parameter change request</td></tr> <tr><td>2</td><td>Cd.2</td><td>Start method</td></tr> <tr><td>3</td><td>Cd.3</td><td>Axis stop</td></tr> <tr><td>4</td><td>Cd.4</td><td>Axis sudden stop</td></tr> <tr><td>5</td><td>Cd.5</td><td>Pausing</td></tr> <tr><td>6</td><td>—</td><td>Unusable</td></tr> <tr><td>7</td><td></td><td></td></tr> <tr><td>8</td><td>Cd.8</td><td>Forward rotation JOG start</td></tr> <tr><td>9</td><td>Cd.9</td><td>Reverse rotation JOG start</td></tr> <tr><td>10</td><td>—</td><td>Unusable</td></tr> <tr><td>11</td><td>Cd.11</td><td>Torque limit request</td></tr> <tr><td>12</td><td>Cd.12</td><td>Forward rotation torque limit value</td></tr> <tr><td>13</td><td>Cd.13</td><td>Reverse rotation torque limit value</td></tr> <tr><td>14</td><td>—</td><td>Unusable</td></tr> <tr><td>15</td><td>Cd.15</td><td>Speed change request</td></tr> <tr><td>16</td><td></td><td></td></tr> <tr><td>17</td><td>Cd.16</td><td>New speed value</td></tr> <tr><td>18</td><td>Cd.18</td><td>Acceleration time change request</td></tr> <tr><td>19</td><td>Cd.19</td><td>New acceleration time value</td></tr> <tr><td>20</td><td>Cd.20</td><td>Deceleration time change request</td></tr> <tr><td>21</td><td>Cd.21</td><td>New deceleration time value</td></tr> <tr><td>22</td><td>—</td><td>Unusable</td></tr> <tr><td>23</td><td>Cd.23</td><td>Target position change request</td></tr> <tr><td>24</td><td></td><td></td></tr> <tr><td>25</td><td>Cd.24</td><td>New target position value</td></tr> <tr><td>26</td><td>—</td><td>Unusable</td></tr> <tr><td>27</td><td></td><td></td></tr> <tr><td>28</td><td></td><td></td></tr> <tr><td>29</td><td>Cd.28</td><td>New current value</td></tr> <tr><td>30</td><td>Cd.30</td><td>Each axis servo OFF</td></tr> <tr><td>31</td><td></td><td></td></tr> <tr><td>32</td><td></td><td></td></tr> <tr><td>33</td><td></td><td></td></tr> <tr><td>34</td><td></td><td></td></tr> <tr><td>35</td><td></td><td></td></tr> <tr><td>36</td><td></td><td></td></tr> <tr><td>37</td><td></td><td></td></tr> <tr><td>38</td><td>—</td><td>Unusable</td></tr> <tr><td>39</td><td></td><td></td></tr> <tr><td>40</td><td></td><td></td></tr> <tr><td>41</td><td></td><td></td></tr> <tr><td>42</td><td></td><td></td></tr> <tr><td>43</td><td></td><td></td></tr> <tr><td>44</td><td></td><td></td></tr> <tr><td>45</td><td></td><td></td></tr> <tr><td>46</td><td>Cd.46</td><td>Gain changing request</td></tr> <tr><td>47</td><td></td><td></td></tr> <tr><td>48</td><td>—</td><td>Unusable</td></tr> <tr><td>49</td><td></td><td></td></tr> </tbody> </table>		Symbol	Parameter item	0	Cd.0	Axis error reset	1	Cd.1	Parameter change request	2	Cd.2	Start method	3	Cd.3	Axis stop	4	Cd.4	Axis sudden stop	5	Cd.5	Pausing	6	—	Unusable	7			8	Cd.8	Forward rotation JOG start	9	Cd.9	Reverse rotation JOG start	10	—	Unusable	11	Cd.11	Torque limit request	12	Cd.12	Forward rotation torque limit value	13	Cd.13	Reverse rotation torque limit value	14	—	Unusable	15	Cd.15	Speed change request	16			17	Cd.16	New speed value	18	Cd.18	Acceleration time change request	19	Cd.19	New acceleration time value	20	Cd.20	Deceleration time change request	21	Cd.21	New deceleration time value	22	—	Unusable	23	Cd.23	Target position change request	24			25	Cd.24	New target position value	26	—	Unusable	27			28			29	Cd.28	New current value	30	Cd.30	Each axis servo OFF	31			32			33			34			35			36			37			38	—	Unusable	39			40			41			42			43			44			45			46	Cd.46	Gain changing request	47			48	—	Unusable	49			<table border="1"> <thead> <tr> <th></th> <th>Symbol</th> <th>Parameter item</th> </tr> </thead> <tbody> <tr><td>50</td><td></td><td></td></tr> <tr><td>51</td><td></td><td></td></tr> <tr><td>52</td><td></td><td></td></tr> <tr><td>53</td><td></td><td></td></tr> <tr><td>54</td><td></td><td></td></tr> <tr><td>55</td><td></td><td></td></tr> <tr><td>56</td><td></td><td></td></tr> <tr><td>57</td><td></td><td></td></tr> <tr><td>58</td><td></td><td></td></tr> <tr><td>59</td><td></td><td></td></tr> <tr><td>60</td><td></td><td></td></tr> <tr><td>61</td><td></td><td></td></tr> <tr><td>62</td><td></td><td></td></tr> <tr><td>63</td><td></td><td></td></tr> <tr><td>64</td><td></td><td></td></tr> <tr><td>65</td><td></td><td></td></tr> <tr><td>66</td><td></td><td></td></tr> <tr><td>67</td><td></td><td></td></tr> <tr><td>68</td><td></td><td></td></tr> <tr><td>69</td><td></td><td></td></tr> <tr><td>70</td><td></td><td></td></tr> <tr><td>71</td><td></td><td></td></tr> <tr><td>72</td><td></td><td></td></tr> <tr><td>73</td><td></td><td></td></tr> <tr><td>74</td><td>—</td><td>Unusable</td></tr> <tr><td>75</td><td></td><td></td></tr> <tr><td>76</td><td></td><td></td></tr> <tr><td>77</td><td></td><td></td></tr> <tr><td>78</td><td></td><td></td></tr> <tr><td>79</td><td></td><td></td></tr> <tr><td>80</td><td></td><td></td></tr> <tr><td>81</td><td></td><td></td></tr> <tr><td>82</td><td></td><td></td></tr> <tr><td>83</td><td></td><td></td></tr> <tr><td>84</td><td></td><td></td></tr> <tr><td>85</td><td></td><td></td></tr> <tr><td>86</td><td></td><td></td></tr> <tr><td>87</td><td></td><td></td></tr> <tr><td>88</td><td></td><td></td></tr> <tr><td>89</td><td></td><td></td></tr> <tr><td>90</td><td></td><td></td></tr> <tr><td>91</td><td></td><td></td></tr> <tr><td>92</td><td></td><td></td></tr> <tr><td>93</td><td></td><td></td></tr> <tr><td>94</td><td></td><td></td></tr> <tr><td>95</td><td></td><td></td></tr> <tr><td>96</td><td></td><td></td></tr> <tr><td>97</td><td></td><td></td></tr> <tr><td>98</td><td></td><td></td></tr> <tr><td>99</td><td></td><td></td></tr> </tbody> </table>		Symbol	Parameter item	50			51			52			53			54			55			56			57			58			59			60			61			62			63			64			65			66			67			68			69			70			71			72			73			74	—	Unusable	75			76			77			78			79			80			81			82			83			84			85			86			87			88			89			90			91			92			93			94			95			96			97			98			99		
	Symbol	Parameter item																																																																																																																																																																																																																																																																																																																			
0	Cd.0	Axis error reset																																																																																																																																																																																																																																																																																																																			
1	Cd.1	Parameter change request																																																																																																																																																																																																																																																																																																																			
2	Cd.2	Start method																																																																																																																																																																																																																																																																																																																			
3	Cd.3	Axis stop																																																																																																																																																																																																																																																																																																																			
4	Cd.4	Axis sudden stop																																																																																																																																																																																																																																																																																																																			
5	Cd.5	Pausing																																																																																																																																																																																																																																																																																																																			
6	—	Unusable																																																																																																																																																																																																																																																																																																																			
7																																																																																																																																																																																																																																																																																																																					
8	Cd.8	Forward rotation JOG start																																																																																																																																																																																																																																																																																																																			
9	Cd.9	Reverse rotation JOG start																																																																																																																																																																																																																																																																																																																			
10	—	Unusable																																																																																																																																																																																																																																																																																																																			
11	Cd.11	Torque limit request																																																																																																																																																																																																																																																																																																																			
12	Cd.12	Forward rotation torque limit value																																																																																																																																																																																																																																																																																																																			
13	Cd.13	Reverse rotation torque limit value																																																																																																																																																																																																																																																																																																																			
14	—	Unusable																																																																																																																																																																																																																																																																																																																			
15	Cd.15	Speed change request																																																																																																																																																																																																																																																																																																																			
16																																																																																																																																																																																																																																																																																																																					
17	Cd.16	New speed value																																																																																																																																																																																																																																																																																																																			
18	Cd.18	Acceleration time change request																																																																																																																																																																																																																																																																																																																			
19	Cd.19	New acceleration time value																																																																																																																																																																																																																																																																																																																			
20	Cd.20	Deceleration time change request																																																																																																																																																																																																																																																																																																																			
21	Cd.21	New deceleration time value																																																																																																																																																																																																																																																																																																																			
22	—	Unusable																																																																																																																																																																																																																																																																																																																			
23	Cd.23	Target position change request																																																																																																																																																																																																																																																																																																																			
24																																																																																																																																																																																																																																																																																																																					
25	Cd.24	New target position value																																																																																																																																																																																																																																																																																																																			
26	—	Unusable																																																																																																																																																																																																																																																																																																																			
27																																																																																																																																																																																																																																																																																																																					
28																																																																																																																																																																																																																																																																																																																					
29	Cd.28	New current value																																																																																																																																																																																																																																																																																																																			
30	Cd.30	Each axis servo OFF																																																																																																																																																																																																																																																																																																																			
31																																																																																																																																																																																																																																																																																																																					
32																																																																																																																																																																																																																																																																																																																					
33																																																																																																																																																																																																																																																																																																																					
34																																																																																																																																																																																																																																																																																																																					
35																																																																																																																																																																																																																																																																																																																					
36																																																																																																																																																																																																																																																																																																																					
37																																																																																																																																																																																																																																																																																																																					
38	—	Unusable																																																																																																																																																																																																																																																																																																																			
39																																																																																																																																																																																																																																																																																																																					
40																																																																																																																																																																																																																																																																																																																					
41																																																																																																																																																																																																																																																																																																																					
42																																																																																																																																																																																																																																																																																																																					
43																																																																																																																																																																																																																																																																																																																					
44																																																																																																																																																																																																																																																																																																																					
45																																																																																																																																																																																																																																																																																																																					
46	Cd.46	Gain changing request																																																																																																																																																																																																																																																																																																																			
47																																																																																																																																																																																																																																																																																																																					
48	—	Unusable																																																																																																																																																																																																																																																																																																																			
49																																																																																																																																																																																																																																																																																																																					
	Symbol	Parameter item																																																																																																																																																																																																																																																																																																																			
50																																																																																																																																																																																																																																																																																																																					
51																																																																																																																																																																																																																																																																																																																					
52																																																																																																																																																																																																																																																																																																																					
53																																																																																																																																																																																																																																																																																																																					
54																																																																																																																																																																																																																																																																																																																					
55																																																																																																																																																																																																																																																																																																																					
56																																																																																																																																																																																																																																																																																																																					
57																																																																																																																																																																																																																																																																																																																					
58																																																																																																																																																																																																																																																																																																																					
59																																																																																																																																																																																																																																																																																																																					
60																																																																																																																																																																																																																																																																																																																					
61																																																																																																																																																																																																																																																																																																																					
62																																																																																																																																																																																																																																																																																																																					
63																																																																																																																																																																																																																																																																																																																					
64																																																																																																																																																																																																																																																																																																																					
65																																																																																																																																																																																																																																																																																																																					
66																																																																																																																																																																																																																																																																																																																					
67																																																																																																																																																																																																																																																																																																																					
68																																																																																																																																																																																																																																																																																																																					
69																																																																																																																																																																																																																																																																																																																					
70																																																																																																																																																																																																																																																																																																																					
71																																																																																																																																																																																																																																																																																																																					
72																																																																																																																																																																																																																																																																																																																					
73																																																																																																																																																																																																																																																																																																																					
74	—	Unusable																																																																																																																																																																																																																																																																																																																			
75																																																																																																																																																																																																																																																																																																																					
76																																																																																																																																																																																																																																																																																																																					
77																																																																																																																																																																																																																																																																																																																					
78																																																																																																																																																																																																																																																																																																																					
79																																																																																																																																																																																																																																																																																																																					
80																																																																																																																																																																																																																																																																																																																					
81																																																																																																																																																																																																																																																																																																																					
82																																																																																																																																																																																																																																																																																																																					
83																																																																																																																																																																																																																																																																																																																					
84																																																																																																																																																																																																																																																																																																																					
85																																																																																																																																																																																																																																																																																																																					
86																																																																																																																																																																																																																																																																																																																					
87																																																																																																																																																																																																																																																																																																																					
88																																																																																																																																																																																																																																																																																																																					
89																																																																																																																																																																																																																																																																																																																					
90																																																																																																																																																																																																																																																																																																																					
91																																																																																																																																																																																																																																																																																																																					
92																																																																																																																																																																																																																																																																																																																					
93																																																																																																																																																																																																																																																																																																																					
94																																																																																																																																																																																																																																																																																																																					
95																																																																																																																																																																																																																																																																																																																					
96																																																																																																																																																																																																																																																																																																																					
97																																																																																																																																																																																																																																																																																																																					
98																																																																																																																																																																																																																																																																																																																					
99																																																																																																																																																																																																																																																																																																																					

(8) List of system control data

Buffer memory address	Symbol	Parameter item	Buffer memory address	Symbol	Parameter item
5000	Cd.100	Flash ROM write request	5050	—	Unusable
5001	Cd.101	Parameter initialization request	5051		
5002			5052		
5003			5053		
5004			5054		
5005			5055		
5006			5056		
5007			5057		
5008			5058		
5009			5059		
5010			5060		
5011			5061		
5012			5062		
5013			5063		
5014			5064		
5015			5065		
5016			5066		
5017			5067		
5018			5068		
5019			5069		
5020			5070		
5021			5071		
5022			5072		
5023			5073		
5024			5074		
5025	—	Unusable	5075		
5026			5076		
5027			5077		
5028			5078		
5029			5079		
5030			5080		
5031			5081		
5032			5082		
5033			5083		
5034			5084		
5035			5085		
5036			5086		
5037			5087		
5038			5088		
5039			5089		
5040			5090		
5041			5091		
5042			5092		
5043			5093		
5044			5094		
5045			5095		
5046			5096		
5047			5097		
5048			5098		
5049			5099		

(9) List of positioning data

Axis No.	Point No.	Buffer memory address	Parameter item	
1	1	5100 to 5109		
	2	5110 to 5119		
	3	5120 to 5129		
	4	5130 to 5139		
	5	5140 to 5149		
	6	5150 to 5159		
	7	5160 to 5169		
	8	5170 to 5179		
	9	5180 to 5189		
	10	5190 to 5199		
	11	5200 to 5209		
	12	5210 to 5219		
	13	5220 to 5229		
	14	5230 to 5239		
	15	5240 to 5249		
	16	5250 to 5259		
	17	5260 to 5269		
	18	5270 to 5279		
	19	5280 to 5289		
	20	5290 to 5299		
	21	5300 to 5309		
	22	5310 to 5319		
	23	5320 to 5329		
	24	5330 to 5339		
	25	5340 to 5349		
	26	5350 to 5359		
	27	5360 to 5369		
	28	5370 to 5379		
	29	5380 to 5389		
	30	5390 to 5399		
	31	5400 to 5409		
	32	5410 to 5419		
2	1	5420 to 5429		
	2	5430 to 5439		
	3	5440 to 5449		
	4	5450 to 5459		
	5	5460 to 5469		
	6	5470 to 5479		
	7	5480 to 5489		
	8	5490 to 5499		
	9	5500 to 5509		
	10	5510 to 5519		
	11	5520 to 5529		
	12	5530 to 5539		
	13	5540 to 5549		
	14	5550 to 5559		
	15	5560 to 5569		
	16	5570 to 5579		
	17	5580 to 5589		
	18	5590 to 5599		
	19	5600 to 5609		
	20	5610 to 5619		
	21	5620 to 5629		
	22	5630 to 5639		
	23	5640 to 5649		
	24	5650 to 5659		
	25	5660 to 5669		
	26	5670 to 5679		
	27	5680 to 5689		
	28	5690 to 5699		
	29	5700 to 5709		
	30	5710 to 5719		
	31	5720 to 5729		
	32	5730 to 5739		

	Symbol	Parameter item
0	Da.0	Operation pattern
1	Da.1	Control system
2	Da.2	Acceleration time
3	Da.3	Deceleration time
4	Da.4	Command speed
6	Da.6	Positioning address/ movement amount
7	Da.7	Dwell time
8	Da.8	Dwell time
9	—	Unusable

Axis No.	Point No.	Buffer memory address	Parameter item	
3	1	5740 to 5749		
	2	5750 to 5759		
	3	5760 to 5769		
	4	5770 to 5779		
	5	5780 to 5789		
	6	5790 to 5799		
	7	5800 to 5809		
	8	5810 to 5819		
	9	5820 to 5829		
	10	5830 to 5839		
	11	5840 to 5849		
	12	5850 to 5859		
	13	5860 to 5869		
	14	5870 to 5879		
	15	5880 to 5889		
	16	5890 to 5899		
	17	5900 to 5909		
	18	5910 to 5919		
	19	5920 to 5929		
	20	5930 to 5939		
	21	5940 to 5949		
	22	5950 to 5959		
	23	5960 to 5969		
	24	5970 to 5979		
	25	5980 to 5989		
	26	5990 to 5999		
	27	6000 to 6009		
	28	6010 to 6019		
	29	6020 to 6029		
	30	6030 to 6039		
	31	6040 to 6049		
	32	6050 to 6059		
4	1	6060 to 6069		
	2	6070 to 6079		
	3	6080 to 6089		
	4	6090 to 6099		
	5	6100 to 6109		
	6	6110 to 6119		
	7	6120 to 6129		
	8	6130 to 6139		
	9	6140 to 6149		
	10	6150 to 6159		
	11	6160 to 6169		
	12	6170 to 6179		
	13	6180 to 6189		
	14	6190 to 6199		
	15	6200 to 6209		
	16	6210 to 6219		
	17	6220 to 6229		
	18	6230 to 6239		
	19	6240 to 6249		
	20	6250 to 6259		
	21	6260 to 6269		
	22	6270 to 6279		
	23	6280 to 6289		
	24	6290 to 6299		
	25	6300 to 6309		
	26	6310 to 6319		
	27	6320 to 6329		
	28	6330 to 6339		
	29	6340 to 6349		
	30	6350 to 6359		
	31	6360 to 6369		
	32	6370 to 6379		

	Symbol	Parameter item
0	Da.0	Operation pattern
1	Da.1	Control system
2	Da.2	Acceleration time
3	Da.3	Deceleration time
4	Da.4	Command speed
6	Da.6	Positioning address/ movement amount
7	Da.7	Dwell time
8	Da.8	Dwell time
9	—	Unusable

List of positioning data (Continued)

Axis No.	Point No.	Buffer memory address	Parameter item	
			Symbol	Parameter item
5	1	6380 to 6389		
	2	6390 to 6399		
	3	6400 to 6409	0	Da.0 Operation pattern
	4	6410 to 6419	1	Da.1 Control system
	5	6420 to 6429	2	Da.2 Acceleration time
	6	6430 to 6439	3	Da.3 Deceleration time
	7	6440 to 6449	4	Da.4 Command speed
	8	6450 to 6459	5	
	9	6460 to 6469	6	Da.6 Positioning address/ movement amount
	10	6470 to 6479	7	
	11	6480 to 6489	8	Da.8 Dwell time
	12	6490 to 6499	9	— Unusable
	13	6500 to 6509		
	14	6510 to 6519		
	15	6520 to 6529		
	16	6530 to 6539		
	17	6540 to 6549		
	18	6550 to 6559		
	19	6560 to 6569		
	20	6570 to 6579		
	21	6580 to 6589		
	22	6590 to 6599		
	23	6600 to 6609		
	24	6610 to 6619		
	25	6620 to 6629		
	26	6630 to 6639		
	27	6640 to 6649		
	28	6650 to 6659		
	29	6660 to 6669		
	30	6670 to 6679		
	31	6680 to 6689		
	32	6690 to 6699		
6	1	6700 to 6709		
	2	6710 to 6719		
	3	6720 to 6729		
	4	6730 to 6739		
	5	6740 to 6749		
	6	6750 to 6759		
	7	6760 to 6769		
	8	6770 to 6779		
	9	6780 to 6789		
	10	6790 to 6799		
	11	6800 to 6809		
	12	6810 to 6819		
	13	6820 to 6829		
	14	6830 to 6839		
	15	6840 to 6849		
	16	6850 to 6859		
	17	6860 to 6869		
	18	6870 to 6879		
	19	6880 to 6889		
	20	6890 to 6899		
	21	6900 to 6909		
	22	6910 to 6919		
	23	6920 to 6929		
	24	6930 to 6939		
	25	6940 to 6949		
	26	6950 to 6959		
	27	6960 to 6969		
	28	6970 to 6979		
	29	6980 to 6989		
	30	6990 to 6999		
	31	7000 to 7009		
	32	7010 to 7019		

Axis No.	Point No.	Buffer memory address	Parameter item	
			Symbol	Parameter item
7	1	7020 to 7029		
	2	7030 to 7039		
	3	7040 to 7049	0	Da.0 Operation pattern
	4	7050 to 7059	1	Da.1 Control system
	5	7060 to 7069	2	Da.2 Acceleration time
	6	7070 to 7079	3	Da.3 Deceleration time
	7	7080 to 7089	4	Da.4 Command speed
	8	7090 to 7099	5	
	9	7100 to 7109	6	Da.6 Positioning address/ movement amount
	10	7110 to 7119	7	
	11	7120 to 7129	8	Da.8 Dwell time
	12	7130 to 7139	9	— Unusable
	13	7140 to 7149		
	14	7150 to 7159		
	15	7160 to 7169		
	16	7170 to 7179		
	17	7180 to 7189		
	18	7190 to 7199		
	19	7200 to 7209		
	20	7210 to 7219		
	21	7220 to 7229		
	22	7230 to 7239		
	23	7240 to 7249		
	24	7250 to 7259		
	25	7260 to 7269		
	26	7270 to 7279		
	27	7280 to 7289		
	28	7290 to 7299		
	29	7300 to 7309		
	30	7310 to 7319		
	31	7320 to 7329		
	32	7330 to 7339		
8	1	7340 to 7349		
	2	7350 to 7359		
	3	7360 to 7369		
	4	7370 to 7379		
	5	7380 to 7389		
	6	7390 to 7399		
	7	7400 to 7409		
	8	7410 to 7419		
	9	7420 to 7429		
	10	7430 to 7439		
	11	7440 to 7449		
	12	7450 to 7459		
	13	7460 to 7469		
	14	7470 to 7479		
	15	7480 to 7489		
	16	7490 to 7499		
	17	7500 to 7509		
	18	7510 to 7519		
	19	7520 to 7529		
	20	7530 to 7539		
	21	7540 to 7549		
	22	7550 to 7559		
	23	7560 to 7569		
	24	7570 to 7579		
	25	7580 to 7589		
	26	7590 to 7599		
	27	7600 to 7609		
	28	7610 to 7619		
	29	7620 to 7629		
	30	7630 to 7639		
	31	7640 to 7649		
	32	7650 to 7659		

List of positioning data (Continued)

Axis No.	Point No.	Buffer memory address	Parameter item		Axis No.	Point No.	Buffer memory address	Parameter item																																																											
9	1	7660 to 7669	<table border="1"> <thead> <tr> <th></th> <th>Symbol</th> <th>Parameter item</th> </tr> </thead> <tbody> <tr> <td>0</td> <td>Da.0</td> <td>Operation pattern</td> </tr> <tr> <td>1</td> <td>Da.1</td> <td>Control system</td> </tr> <tr> <td>2</td> <td>Da.2</td> <td>Acceleration time</td> </tr> <tr> <td>3</td> <td>Da.3</td> <td>Deceleration time</td> </tr> <tr> <td>4</td> <td rowspan="2">Da.4</td> <td rowspan="2">Command speed</td> </tr> <tr> <td>5</td> </tr> <tr> <td>6</td> <td rowspan="2">Da.6</td> <td rowspan="2">Positioning address/ movement amount</td> </tr> <tr> <td>7</td> </tr> <tr> <td>8</td> <td>Da.8</td> <td>Dwell time</td> </tr> <tr> <td>9</td> <td>—</td> <td>Unusable</td> </tr> </tbody> </table>		Symbol	Parameter item	0	Da.0	Operation pattern	1	Da.1	Control system	2	Da.2	Acceleration time	3	Da.3	Deceleration time	4	Da.4	Command speed	5	6	Da.6	Positioning address/ movement amount	7	8	Da.8	Dwell time	9	—	Unusable		11	1	8300 to 8309	<table border="1"> <thead> <tr> <th></th> <th>Symbol</th> <th>Parameter item</th> </tr> </thead> <tbody> <tr> <td>0</td> <td>Da.0</td> <td>Operation pattern</td> </tr> <tr> <td>1</td> <td>Da.1</td> <td>Control system</td> </tr> <tr> <td>2</td> <td>Da.2</td> <td>Acceleration time</td> </tr> <tr> <td>3</td> <td>Da.3</td> <td>Deceleration time</td> </tr> <tr> <td>4</td> <td rowspan="2">Da.4</td> <td rowspan="2">Command speed</td> </tr> <tr> <td>5</td> </tr> <tr> <td>6</td> <td rowspan="2">Da.6</td> <td rowspan="2">Positioning address/ movement amount</td> </tr> <tr> <td>7</td> </tr> <tr> <td>8</td> <td>Da.8</td> <td>Dwell time</td> </tr> <tr> <td>9</td> <td>—</td> <td>Unusable</td> </tr> </tbody> </table>		Symbol	Parameter item	0	Da.0	Operation pattern	1	Da.1	Control system	2	Da.2	Acceleration time	3	Da.3	Deceleration time	4	Da.4	Command speed	5	6	Da.6	Positioning address/ movement amount	7	8	Da.8	Dwell time	9	—	Unusable	
		Symbol		Parameter item																																																															
	0	Da.0		Operation pattern																																																															
	1	Da.1		Control system																																																															
	2	Da.2		Acceleration time																																																															
	3	Da.3		Deceleration time																																																															
	4	Da.4		Command speed																																																															
	5																																																																		
	6	Da.6		Positioning address/ movement amount																																																															
	7																																																																		
	8	Da.8	Dwell time																																																																
	9	—	Unusable																																																																
		Symbol	Parameter item																																																																
	0	Da.0	Operation pattern																																																																
	1	Da.1	Control system																																																																
	2	Da.2	Acceleration time																																																																
	3	Da.3	Deceleration time																																																																
	4	Da.4	Command speed																																																																
	5																																																																		
	6	Da.6	Positioning address/ movement amount																																																																
	7																																																																		
	8	Da.8	Dwell time																																																																
	9	—	Unusable																																																																
		2	7670 to 7679			2	8310 to 8319																																																												
		3	7680 to 7689			3	8320 to 8329																																																												
		4	7690 to 7699			4	8330 to 8339																																																												
		5	7700 to 7709			5	8340 to 8349																																																												
		6	7710 to 7719			6	8350 to 8359																																																												
		7	7720 to 7729			7	8360 to 8369																																																												
		8	7730 to 7739			8	8370 to 8379																																																												
		9	7740 to 7749			9	8380 to 8389																																																												
		10	7750 to 7759			10	8390 to 8399																																																												
	11	7760 to 7769			11	8400 to 8409																																																													
	12	7770 to 7779			12	8410 to 8419																																																													
	13	7780 to 7789			13	8420 to 8429																																																													
	14	7790 to 7799			14	8430 to 8439																																																													
	15	7800 to 7809			15	8440 to 8449																																																													
	16	7810 to 7819			16	8450 to 8459																																																													
	17	7820 to 7829			17	8460 to 8469																																																													
	18	7830 to 7839			18	8470 to 8479																																																													
	19	7840 to 7849			19	8480 to 8489																																																													
	20	7850 to 7859			20	8490 to 8499																																																													
	21	7860 to 7869			21	8500 to 8509																																																													
	22	7870 to 7879			22	8510 to 8519																																																													
	23	7880 to 7889			23	8520 to 8529																																																													
	24	7890 to 7899			24	8530 to 8539																																																													
	25	7900 to 7909			25	8540 to 8549																																																													
	26	7910 to 7919			26	8550 to 8559																																																													
	27	7920 to 7929			27	8560 to 8569																																																													
	28	7930 to 7939			28	8570 to 8579																																																													
	29	7940 to 7949			29	8580 to 8589																																																													
	30	7950 to 7959			30	8590 to 8599																																																													
	31	7960 to 7969			31	8600 to 8609																																																													
	32	7970 to 7979			32	8610 to 8619																																																													
10	1	7980 to 7989			12	1	8620 to 8629																																																												
		2	7990 to 7999				2	8630 to 8639																																																											
		3	8000 to 8009				3	8640 to 8649																																																											
		4	8010 to 8019				4	8650 to 8659																																																											
		5	8020 to 8029				5	8660 to 8669																																																											
		6	8030 to 8039				6	8670 to 8679																																																											
		7	8040 to 8049				7	8680 to 8689																																																											
		8	8050 to 8059				8	8690 to 8699																																																											
		9	8060 to 8069				9	8700 to 8709																																																											
		10	8070 to 8079				10	8710 to 8719																																																											
		11	8080 to 8089				11	8720 to 8729																																																											
		12	8090 to 8099				12	8730 to 8739																																																											
		13	8100 to 8109				13	8740 to 8749																																																											
		14	8110 to 8119				14	8750 to 8759																																																											
		15	8120 to 8129				15	8760 to 8769																																																											
		16	8130 to 8139				16	8770 to 8779																																																											
		17	8140 to 8149				17	8780 to 8789																																																											
		18	8150 to 8159				18	8790 to 8799																																																											
		19	8160 to 8169				19	8800 to 8809																																																											
		20	8170 to 8179				20	8810 to 8819																																																											
		21	8180 to 8189				21	8820 to 8829																																																											
		22	8190 to 8199				22	8830 to 8839																																																											
		23	8200 to 8209				23	8840 to 8849																																																											
		24	8210 to 8219				24	8850 to 8859																																																											
		25	8220 to 8229				25	8860 to 8869																																																											
		26	8230 to 8239				26	8870 to 8879																																																											
		27	8240 to 8249				27	8880 to 8889																																																											
		28	8250 to 8259				28	8890 to 8899																																																											
		29	8260 to 8269				29	8900 to 8909																																																											
		30	8270 to 8279				30	8910 to 8919																																																											
		31	8280 to 8289				31	8920 to 8929																																																											
		32	8290 to 8299				32	8930 to 8939																																																											

List of positioning data (Continued)

Axis No.	Point No.	Buffer memory address	Parameter item	
13	1	8940 to 8949		
	2	8950 to 8959		
	3	8960 to 8969		
	4	8970 to 8979		
	5	8980 to 8989		
	6	8990 to 8999		
	7	9000 to 9009		
	8	9010 to 9019		
	9	9020 to 9029		
	10	9030 to 9039		
	11	9040 to 9049		
	12	9050 to 9059		
	13	9060 to 9069		
	14	9070 to 9079		
	15	9080 to 9089		
	16	9090 to 9099		
	17	9100 to 9109		
	18	9110 to 9119		
	19	9120 to 9129		
	20	9130 to 9139		
	21	9140 to 9149		
	22	9150 to 9159		
	23	9160 to 9169		
	24	9170 to 9179		
	25	9180 to 9189		
	26	9190 to 9199		
	27	9200 to 9209		
	28	9210 to 9219		
	29	9220 to 9229		
	30	9230 to 9239		
	31	9240 to 9249		
	32	9250 to 9259		
14	1	9260 to 9269		
	2	9270 to 9279		
	3	9280 to 9289		
	4	9290 to 9299		
	5	9300 to 9309		
	6	9310 to 9319		
	7	9320 to 9329		
	8	9330 to 9339		
	9	9340 to 9349		
	10	9350 to 9359		
	11	9360 to 9369		
	12	9370 to 9379		
	13	9380 to 9389		
	14	9390 to 9399		
	15	9400 to 9409		
	16	9410 to 9419		
	17	9420 to 9429		
	18	9430 to 9439		
	19	9440 to 9449		
	20	9450 to 9459		
	21	9460 to 9469		
	22	9470 to 9479		
	23	9480 to 9489		
	24	9490 to 9499		
	25	9500 to 9509		
	26	9510 to 9519		
	27	9520 to 9529		
	28	9530 to 9539		
	29	9540 to 9549		
	30	9550 to 9559		
	31	9560 to 9569		
	32	9570 to 9579		

Symbol	Parameter item
0 Da.0	Operation pattern
1 Da.1	Control system
2 Da.2	Acceleration time
3 Da.3	Deceleration time
4 Da.4	Command speed
6 Da.6	Positioning address/ movement amount
8 Da.8	Dwell time
9 —	Unusable

Axis No.	Point No.	Buffer memory address	Parameter item	
15	1	9580 to 9589		
	2	9590 to 9599		
	3	9600 to 9609		
	4	9610 to 9619		
	5	9620 to 9629		
	6	9630 to 9639		
	7	9640 to 9649		
	8	9650 to 9659		
	9	9660 to 9669		
	10	9670 to 9679		
	11	9680 to 9689		
	12	9690 to 9699		
	13	9700 to 9709		
	14	9710 to 9719		
	15	9720 to 9729		
	16	9730 to 9739		
	17	9740 to 9749		
	18	9750 to 9759		
	19	9760 to 9769		
	20	9770 to 9779		
	21	9780 to 9789		
	22	9790 to 9799		
	23	9800 to 9809		
	24	9810 to 9819		
	25	9820 to 9829		
	26	9830 to 9839		
	27	9840 to 9849		
	28	9850 to 9859		
	29	9860 to 9869		
	30	9870 to 9879		
	31	9880 to 9889		
	32	9890 to 9899		
16	1	9900 to 9909		
	2	9910 to 9919		
	3	9920 to 9929		
	4	9930 to 9939		
	5	9940 to 9949		
	6	9950 to 9959		
	7	9960 to 9969		
	8	9970 to 9979		
	9	9980 to 9989		
	10	9990 to 9999		
	11	10000 to 10009		
	12	10010 to 10019		
	13	10020 to 10029		
	14	10030 to 10039		
	15	10040 to 10049		
	16	10050 to 10059		
	17	10060 to 10069		
	18	10070 to 10079		
	19	10080 to 10089		
	20	10090 to 10099		
	21	10100 to 10109		
	22	10110 to 10119		
	23	10120 to 10129		
	24	10130 to 10139		
	25	10140 to 10149		
	26	10150 to 10159		
	27	10160 to 10169		
	28	10170 to 10179		
	29	10180 to 10189		
	30	10190 to 10199		
	31	10200 to 10209		
	32	10210 to 10219		

Symbol	Parameter item
0 Da.0	Operation pattern
1 Da.1	Control system
2 Da.2	Acceleration time
3 Da.3	Deceleration time
4 Da.4	Command speed
6 Da.6	Positioning address/ movement amount
8 Da.8	Dwell time
9 —	Unusable

(9) List of servo parameter

Axis No.	Buffer memory address	Parameter item																																																																																																																																																																																																																																																																																																																																																																																																																																																																																										
1	10300 to 10599													2	10600 to 10899													3	10900 to 11199	0	Pr.300	—	Servo series	45	Pr.345	PB13	Machine resonance suppression filter 1	51	Pr.351	PB19	Vibration suppression control vibration frequency setting	4	11200 to 11499	1	Pr.301	PA01	For manufacturer setting	46	Pr.346	PB14	Notch shape selection 1	52	Pr.352	PB20	Vibration suppression control resonance frequency setting	5	11500 to 11799	2	Pr.302	PA02	Regenerative option	47	Pr.347	PB15	Machine resonance suppression filter 2	53	Pr.353	PB21	For manufacturer setting	6	11800 to 12099	3	Pr.303	PA03	Absolute position detection system	48	Pr.348	PB16	Notch shape selection 2	54	Pr.354	PB22	For manufacturer setting	7	12100 to 12399	4	Pr.304	PA04	Function selection A-1	49	Pr.349	PB17	Automatic setting parameter	55	Pr.355	PB23	Low-pass filter selection	8	12400 to 12699	5	Pr.305	PA05	For manufacturer setting	50	Pr.350	PB18	Low-pass filter setting	56	Pr.356	PB24	Slight vibration suppression control selection	9	12700 to 12999	6	Pr.306	PA06	For manufacturer setting	57	Pr.357	PB25	For manufacturer setting	58	Pr.358	PB26	Gain changing selection	10	13000 to 13299	7	Pr.307	PA07	59	Pr.359	PB27	Gain changing condition	11	13300 to 13599	8	Pr.308	PA08	Auto tuning mode	60	Pr.360	PB28	Gain changing time constant	61	Pr.361	PB29	Gain changing ratio of load inertia moment to servomotor inertia moment	12	13600 to 13899	9	Pr.309	PA09	Auto tuning response	62	Pr.362	PB30	Gain changing position loop gain	63	Pr.363	PB31	Gain changing speed loop gain	13	13900 to 14199	10	Pr.310	PA10	In-position range	64	Pr.364	PB32	Gain changing speed integral compensation	65	Pr.365	PB33	Gain changing vibration suppression control vibration frequency setting	14	14200 to 14499	11	Pr.311	PA11	For manufacturer setting	66	Pr.366	PB34	Gain changing vibration suppression control resonance frequency setting	67	Pr.367	PB35	For manufacturer setting	15	14500 to 14799	12	Pr.312	PA12	68	Pr.368	PB36	For manufacturer setting	16	14800 to 15099	13	Pr.313	PA13	69	Pr.369	PB37			14	Pr.314	PA14	Rotation direction selection	70	Pr.370	PB38			15	Pr.315	PA15	Encoder output pulses	71	Pr.371	PB39			16	Pr.316	PA16	For manufacturer setting	72	Pr.372	PB40			17	Pr.317	PA17	73	Pr.373	PB41			18	Pr.318	PA18	74	Pr.374	PB42			19	Pr.319	PA19	75	Pr.375	PB43			20	Pr.320	—	76	Pr.376	PB44			21	Pr.321	77	Pr.377	PB45			22	Pr.322	78	Pr.378	—			23	Pr.323	79	Pr.379			24	Pr.324	80	Pr.380			25	Pr.325	81	Pr.381	PC01	Error excessive alarm level			26	Pr.326	82	Pr.382	PC02	Electromagnetic brake sequence output			27	Pr.327	83	Pr.383	PC03	Encoder output pulses selection			28	Pr.328	84	Pr.384	PC04	Function selection C-1			29	Pr.329	85	Pr.385	PC05	Function selection C-2			30	Pr.330	86	Pr.386	PC06	Function selection C-3			31	Pr.331	87	Pr.387	PC07	Zero speed			32	Pr.332	88	Pr.388	PC08	For manufacturer setting			33	Pr.333	PB01	Adaptive tuning mode (Adaptive filter II)	89	Pr.389	PC09	Analog monitor 1 output			34	Pr.334	PB02	Vibration suppression control tuning mode (advanced vibration suppression control)							35	Pr.335	PB03	For manufacturer setting							36	Pr.336	PB04	Feed forward gain							37	Pr.337	PB05	For manufacturer setting							38	Pr.338	PB06	Ratio of load inertia moment to servo motor inertia moment							39	Pr.339	PB07	Model loop gain							40	Pr.340	PB08	Position loop gain							41	Pr.341	PB09	Speed loop gain							42	Pr.342	PB10	Speed integral compensation							43	Pr.343	PB11	Speed differential compensation							44	Pr.344	PB12	For manufacturer setting				
2	10600 to 10899													3	10900 to 11199	0	Pr.300	—	Servo series	45	Pr.345	PB13	Machine resonance suppression filter 1	51	Pr.351	PB19	Vibration suppression control vibration frequency setting	4	11200 to 11499	1	Pr.301	PA01	For manufacturer setting	46	Pr.346	PB14	Notch shape selection 1	52	Pr.352	PB20	Vibration suppression control resonance frequency setting	5	11500 to 11799	2	Pr.302	PA02	Regenerative option	47	Pr.347	PB15	Machine resonance suppression filter 2	53	Pr.353	PB21	For manufacturer setting	6	11800 to 12099	3	Pr.303	PA03	Absolute position detection system	48	Pr.348	PB16	Notch shape selection 2	54	Pr.354	PB22	For manufacturer setting	7	12100 to 12399	4	Pr.304	PA04	Function selection A-1	49	Pr.349	PB17	Automatic setting parameter	55	Pr.355	PB23	Low-pass filter selection	8	12400 to 12699	5	Pr.305	PA05	For manufacturer setting	50	Pr.350	PB18	Low-pass filter setting	56	Pr.356	PB24	Slight vibration suppression control selection	9	12700 to 12999	6	Pr.306	PA06		For manufacturer setting	57	Pr.357	PB25	For manufacturer setting	58	Pr.358	PB26	Gain changing selection	10	13000 to 13299	7	Pr.307		PA07	59	Pr.359	PB27	Gain changing condition	11	13300 to 13599	8	Pr.308	PA08	Auto tuning mode	60	Pr.360	PB28	Gain changing time constant	61	Pr.361	PB29	Gain changing ratio of load inertia moment to servomotor inertia moment	12	13600 to 13899	9	Pr.309	PA09	Auto tuning response	62	Pr.362	PB30	Gain changing position loop gain	63	Pr.363	PB31	Gain changing speed loop gain	13	13900 to 14199	10	Pr.310	PA10	In-position range	64	Pr.364	PB32	Gain changing speed integral compensation	65	Pr.365	PB33	Gain changing vibration suppression control vibration frequency setting	14	14200 to 14499	11	Pr.311	PA11	For manufacturer setting	66	Pr.366	PB34	Gain changing vibration suppression control resonance frequency setting	67	Pr.367	PB35	For manufacturer setting	15	14500 to 14799	12		Pr.312	PA12	68	Pr.368	PB36	For manufacturer setting	16		14800 to 15099	13	Pr.313	PA13	69	Pr.369	PB37				14	Pr.314	PA14	Rotation direction selection	70	Pr.370	PB38			15	Pr.315	PA15	Encoder output pulses	71	Pr.371	PB39			16	Pr.316	PA16	For manufacturer setting	72	Pr.372	PB40			17	Pr.317	PA17		73	Pr.373	PB41			18	Pr.318	PA18	74	Pr.374	PB42			19	Pr.319	PA19	75	Pr.375	PB43			20	Pr.320	—	76	Pr.376	PB44			21	Pr.321		77	Pr.377	PB45			22	Pr.322	78	Pr.378	—			23	Pr.323	79	Pr.379				24	Pr.324	80	Pr.380			25	Pr.325	81	Pr.381	PC01	Error excessive alarm level			26	Pr.326	82	Pr.382	PC02	Electromagnetic brake sequence output			27	Pr.327	83	Pr.383	PC03	Encoder output pulses selection			28	Pr.328	84	Pr.384	PC04	Function selection C-1			29	Pr.329	85	Pr.385	PC05	Function selection C-2			30	Pr.330	86	Pr.386	PC06	Function selection C-3			31	Pr.331	87	Pr.387	PC07	Zero speed			32	Pr.332	88	Pr.388	PC08	For manufacturer setting			33	Pr.333	PB01	Adaptive tuning mode (Adaptive filter II)	89	Pr.389	PC09	Analog monitor 1 output			34	Pr.334	PB02	Vibration suppression control tuning mode (advanced vibration suppression control)							35	Pr.335	PB03	For manufacturer setting							36	Pr.336	PB04	Feed forward gain							37	Pr.337	PB05	For manufacturer setting							38	Pr.338	PB06	Ratio of load inertia moment to servo motor inertia moment							39	Pr.339	PB07	Model loop gain							40	Pr.340	PB08	Position loop gain							41	Pr.341	PB09	Speed loop gain							42	Pr.342	PB10	Speed integral compensation							43	Pr.343	PB11	Speed differential compensation							44	Pr.344	PB12	For manufacturer setting										
3	10900 to 11199	0	Pr.300	—	Servo series	45	Pr.345	PB13	Machine resonance suppression filter 1	51	Pr.351	PB19	Vibration suppression control vibration frequency setting																																																																																																																																																																																																																																																																																																																																																																																																																																																																															
4	11200 to 11499	1	Pr.301	PA01	For manufacturer setting	46	Pr.346	PB14	Notch shape selection 1	52	Pr.352	PB20	Vibration suppression control resonance frequency setting																																																																																																																																																																																																																																																																																																																																																																																																																																																																															
5	11500 to 11799	2	Pr.302	PA02	Regenerative option	47	Pr.347	PB15	Machine resonance suppression filter 2	53	Pr.353	PB21	For manufacturer setting																																																																																																																																																																																																																																																																																																																																																																																																																																																																															
6	11800 to 12099	3	Pr.303	PA03	Absolute position detection system	48	Pr.348	PB16	Notch shape selection 2	54	Pr.354	PB22	For manufacturer setting																																																																																																																																																																																																																																																																																																																																																																																																																																																																															
7	12100 to 12399	4	Pr.304	PA04	Function selection A-1	49	Pr.349	PB17	Automatic setting parameter	55	Pr.355	PB23	Low-pass filter selection																																																																																																																																																																																																																																																																																																																																																																																																																																																																															
8	12400 to 12699	5	Pr.305	PA05	For manufacturer setting	50	Pr.350	PB18	Low-pass filter setting	56	Pr.356	PB24	Slight vibration suppression control selection																																																																																																																																																																																																																																																																																																																																																																																																																																																																															
9	12700 to 12999	6	Pr.306	PA06		For manufacturer setting	57	Pr.357	PB25	For manufacturer setting	58	Pr.358	PB26	Gain changing selection																																																																																																																																																																																																																																																																																																																																																																																																																																																																														
10	13000 to 13299	7	Pr.307	PA07			59	Pr.359	PB27	Gain changing condition																																																																																																																																																																																																																																																																																																																																																																																																																																																																																		
11	13300 to 13599	8	Pr.308	PA08	Auto tuning mode	60	Pr.360	PB28	Gain changing time constant	61	Pr.361	PB29	Gain changing ratio of load inertia moment to servomotor inertia moment																																																																																																																																																																																																																																																																																																																																																																																																																																																																															
12	13600 to 13899	9	Pr.309	PA09	Auto tuning response	62	Pr.362	PB30	Gain changing position loop gain	63	Pr.363	PB31	Gain changing speed loop gain																																																																																																																																																																																																																																																																																																																																																																																																																																																																															
13	13900 to 14199	10	Pr.310	PA10	In-position range	64	Pr.364	PB32	Gain changing speed integral compensation	65	Pr.365	PB33	Gain changing vibration suppression control vibration frequency setting																																																																																																																																																																																																																																																																																																																																																																																																																																																																															
14	14200 to 14499	11	Pr.311	PA11	For manufacturer setting	66	Pr.366	PB34	Gain changing vibration suppression control resonance frequency setting	67	Pr.367	PB35	For manufacturer setting																																																																																																																																																																																																																																																																																																																																																																																																																																																																															
15	14500 to 14799	12	Pr.312	PA12		68	Pr.368	PB36	For manufacturer setting																																																																																																																																																																																																																																																																																																																																																																																																																																																																																			
16	14800 to 15099	13	Pr.313	PA13	69	Pr.369	PB37																																																																																																																																																																																																																																																																																																																																																																																																																																																																																					
		14	Pr.314	PA14	Rotation direction selection	70	Pr.370	PB38																																																																																																																																																																																																																																																																																																																																																																																																																																																																																				
		15	Pr.315	PA15	Encoder output pulses	71	Pr.371	PB39																																																																																																																																																																																																																																																																																																																																																																																																																																																																																				
		16	Pr.316	PA16	For manufacturer setting	72	Pr.372	PB40																																																																																																																																																																																																																																																																																																																																																																																																																																																																																				
		17	Pr.317	PA17		73	Pr.373	PB41																																																																																																																																																																																																																																																																																																																																																																																																																																																																																				
		18	Pr.318	PA18		74	Pr.374	PB42																																																																																																																																																																																																																																																																																																																																																																																																																																																																																				
		19	Pr.319	PA19		75	Pr.375	PB43																																																																																																																																																																																																																																																																																																																																																																																																																																																																																				
		20	Pr.320	—		76	Pr.376	PB44																																																																																																																																																																																																																																																																																																																																																																																																																																																																																				
		21	Pr.321			77	Pr.377	PB45																																																																																																																																																																																																																																																																																																																																																																																																																																																																																				
		22	Pr.322			78	Pr.378	—																																																																																																																																																																																																																																																																																																																																																																																																																																																																																				
		23	Pr.323			79	Pr.379																																																																																																																																																																																																																																																																																																																																																																																																																																																																																					
		24	Pr.324			80	Pr.380																																																																																																																																																																																																																																																																																																																																																																																																																																																																																					
		25	Pr.325			81	Pr.381		PC01	Error excessive alarm level																																																																																																																																																																																																																																																																																																																																																																																																																																																																																		
		26	Pr.326		82	Pr.382	PC02		Electromagnetic brake sequence output																																																																																																																																																																																																																																																																																																																																																																																																																																																																																			
		27	Pr.327		83	Pr.383	PC03		Encoder output pulses selection																																																																																																																																																																																																																																																																																																																																																																																																																																																																																			
		28	Pr.328		84	Pr.384	PC04		Function selection C-1																																																																																																																																																																																																																																																																																																																																																																																																																																																																																			
		29	Pr.329		85	Pr.385	PC05		Function selection C-2																																																																																																																																																																																																																																																																																																																																																																																																																																																																																			
		30	Pr.330	86	Pr.386	PC06	Function selection C-3																																																																																																																																																																																																																																																																																																																																																																																																																																																																																					
		31	Pr.331	87	Pr.387	PC07	Zero speed																																																																																																																																																																																																																																																																																																																																																																																																																																																																																					
		32	Pr.332	88	Pr.388	PC08	For manufacturer setting																																																																																																																																																																																																																																																																																																																																																																																																																																																																																					
		33	Pr.333	PB01	Adaptive tuning mode (Adaptive filter II)	89	Pr.389	PC09	Analog monitor 1 output																																																																																																																																																																																																																																																																																																																																																																																																																																																																																			
		34	Pr.334	PB02	Vibration suppression control tuning mode (advanced vibration suppression control)																																																																																																																																																																																																																																																																																																																																																																																																																																																																																							
		35	Pr.335	PB03	For manufacturer setting																																																																																																																																																																																																																																																																																																																																																																																																																																																																																							
		36	Pr.336	PB04	Feed forward gain																																																																																																																																																																																																																																																																																																																																																																																																																																																																																							
		37	Pr.337	PB05	For manufacturer setting																																																																																																																																																																																																																																																																																																																																																																																																																																																																																							
		38	Pr.338	PB06	Ratio of load inertia moment to servo motor inertia moment																																																																																																																																																																																																																																																																																																																																																																																																																																																																																							
		39	Pr.339	PB07	Model loop gain																																																																																																																																																																																																																																																																																																																																																																																																																																																																																							
		40	Pr.340	PB08	Position loop gain																																																																																																																																																																																																																																																																																																																																																																																																																																																																																							
		41	Pr.341	PB09	Speed loop gain																																																																																																																																																																																																																																																																																																																																																																																																																																																																																							
		42	Pr.342	PB10	Speed integral compensation																																																																																																																																																																																																																																																																																																																																																																																																																																																																																							
		43	Pr.343	PB11	Speed differential compensation																																																																																																																																																																																																																																																																																																																																																																																																																																																																																							
		44	Pr.344	PB12	For manufacturer setting																																																																																																																																																																																																																																																																																																																																																																																																																																																																																							

List of servo parameter (Continued)

Axis No.	Buffer memory address	Parameter item								
1	10300 to 10599									
2	10600 to 10899									
3	10900 to 11199	90	Pr.390	PC10	Analog monitor 2 output	143	Pr.443	PD31		
4	11200 to 11499	91	Pr.391	PC11	Analog monitor 1 offset	144	Pr.444	PD32		
5	11500 to 11799	92	Pr.392	PC12	Analog monitor 2 offset	145	Pr.445	PE01		
6	11800 to 12099	93	Pr.393	PC13	Analog monitor feedback position output standard data Low	146	Pr.446	PE02		
7	12100 to 12399	94	Pr.394	PC14	Analog monitor feedback position output standard data High	147	Pr.447	PE03		
8	12400 to 12699	95	Pr.395	PC15	For manufacturer setting	148	Pr.448	PE04		
9	12700 to 12999	96	Pr.396	PC16		149	Pr.449	PE05		
10	13000 to 13299	97	Pr.397	PC17	Function selection C-4	150	Pr.450	PE06		
11	13300 to 13599	98	Pr.398	PC18	For manufacturer setting	151	Pr.451	PE07		
12	13600 to 13899	99	Pr.399	PC19		152	Pr.452	PE08		
13	13900 to 14199	100	Pr.400	PC20		153	Pr.453	PE09		
14	14200 to 14499	101	Pr.401	PC21	Alarm history clear	154	Pr.454	PE10		
15	14500 to 14799	102	Pr.402	PC22	For manufacturer setting	155	Pr.455	PE11	For manufacturer setting	
16	14800 to 15099	103	Pr.403	PC23		156	Pr.456	PE12		
		104	Pr.404	PC24		157	Pr.457	PE13		
		105	Pr.405	PC25		158	Pr.458	PE14		
		106	Pr.406	PC26		159	Pr.459	PE15		
		107	Pr.407	PC27		160	Pr.460	PE16		
		108	Pr.408	PC28		161	Pr.461	PE17		
		109	Pr.409	PC29		162	Pr.462	PE18		
		110	Pr.410	PC30		For manufacturer setting	163	Pr.463		PE19
		111	Pr.411	PC31			164	Pr.464		PE20
		112	Pr.412	PC32		165	Pr.465	PE21		
		113	Pr.413	PD01		166	Pr.466	PE22		
		114	Pr.414	PD02		167	Pr.467	PE23		
		115	Pr.415	PD03		168	Pr.468	PE24		
		116	Pr.416	PD04		169	Pr.469	PE25		
		117	Pr.417	PD05		170	Pr.470	PE26	Filter coefficient 2-1	
		118	Pr.418	PD06		171	Pr.471	PE27	Filter coefficient 2-2	
		119	Pr.419	PD07	Output signal device selection 1	172	Pr.472	PE28	Filter coefficient 2-3	
		120	Pr.420	PD08	Output signal device selection 2	173	Pr.473	PE29	Filter coefficient 2-4	
		121	Pr.421	PD09	Output signal device selection 3	174	Pr.474	PE30	Filter coefficient 2-5	
		122	Pr.422	PD10	For manufacturer setting	175	Pr.475	PE31	Filter coefficient 2-6	
		123	Pr.423	PD11		176	Pr.476	PE32	Filter coefficient 2-7	
		124	Pr.424	PD12		177	Pr.477	PE33	Filter coefficient 2-8	
		125	Pr.425	PD13		178	Pr.478	PE34	For manufacturer setting	
		126	Pr.426	PD14	Function selection D-3	179	Pr.479	PE35		
		127	Pr.427	PD15	For manufacturer setting	180	Pr.480	PE36		
		128	Pr.428	PD16		181	Pr.481	PE37		
		129	Pr.429	PD17		182	Pr.482	PE38		
		130	Pr.430	PD18		183	Pr.483	PE39		
		131	Pr.431	PD19		184	Pr.484	PE40		
		132	Pr.432	PD20		185	Pr.485			
		133	Pr.433	PD21		186	Pr.486			
		134	Pr.434	PD22		187	Pr.487			
		135	Pr.435	PD23	188	Pr.488				
		136	Pr.436	PD24	189	Pr.489				
		137	Pr.437	PD25	190	Pr.490				
		138	Pr.438	PD26	191	Pr.491				
		139	Pr.439	PD27	192	Pr.492				
		140	Pr.440	PD28	193	Pr.493	PS01			
		141	Pr.441	PD29	194	Pr.494	PS02			
		142	Pr.442	PD30	195	Pr.495	PS03			

List of servo parameter (Continued)

Axis No.	Buffer memory address	Parameter item								
1	10300 to 10599									
2	10600 to 10899									
3	10900 to 11199	196	Pr.496	PS04				248	Pr.548	
4	11200 to 11499	197	Pr.497	PS05				249	Pr.549	
5	11500 to 11799	198	Pr.498	PS06				250	Pr.550	
6	11800 to 12099	199	Pr.499	PS07				251	Pr.551	
7	12100 to 12399	200	Pr.500	PS08				252	Pr.552	
8	12400 to 12699	201	Pr.501	PS09				253	Pr.553	
9	12700 to 12999	202	Pr.502	PS10				254	Pr.554	
10	13000 to 13299	203	Pr.503	PS11				255	Pr.555	
11	13300 to 13599	204	Pr.504	PS12				256	Pr.556	
12	13600 to 13899	205	Pr.505	PS13				257	Pr.557	
13	13900 to 14199	206	Pr.506	PS14				258	Pr.558	
14	14200 to 14499	207	Pr.507	PS15				259	Pr.559	
15	14500 to 14799	208	Pr.508	PS16				260	Pr.560	
16	14800 to 15099	209	Pr.509	PS17				261	Pr.561	
		210	Pr.510	PS18				262	Pr.562	
		211	Pr.511	PS19				263	Pr.563	
		212	Pr.512	PS20				264	Pr.564	
		213	Pr.513	PS21				265	Pr.565	
		214	Pr.514	PS22				266	Pr.566	
		215	Pr.515	PS23				267	Pr.567	
		216	Pr.516	PS24				268	Pr.568	
		217	Pr.517	PS25				269	Pr.569	
		218	Pr.518	PS26				270	Pr.570	
		219	Pr.519	PS27				271	Pr.571	
		220	Pr.520	PS28				272	Pr.572	
		221	Pr.521	PS29	For manufacturer setting				273	Pr.573
		222	Pr.522	PS30					274	Pr.574
		223	Pr.523	PS31					275	Pr.575
		224	Pr.524	PS32					276	Pr.576
		225	Pr.525						277	Pr.577
		226	Pr.526						278	Pr.578
		227	Pr.527						279	Pr.579
		228	Pr.528						280	Pr.580
		229	Pr.529						281	Pr.581
		230	Pr.530						282	Pr.582
		231	Pr.531					283	Pr.583	
		232	Pr.532					284	Pr.584	
		233	Pr.533					285	Pr.585	
		234	Pr.534					286	Pr.586	
		235	Pr.535					287	Pr.587	
		236	Pr.536	—				288	Pr.588	
		237	Pr.537					289	Pr.589	
		238	Pr.538					290	Pr.590	
		239	Pr.539					291	Pr.591	
		240	Pr.540					292	Pr.592	
		241	Pr.541					293	Pr.593	
		242	Pr.542					294	Pr.594	
		243	Pr.543					295	Pr.595	
		244	Pr.544					296	Pr.596	
		245	Pr.545					297	Pr.597	
		246	Pr.546					298	Pr.598	
		247	Pr.547					299	Pr.599	

6.4 Parameter Data

The setting value of parameters (basic, OPR, system) is checked at the PLC READY ON. (The manual control parameters cannot be checked.)

If the setting value is outside the range, the error code will occur and the unit READY cannot be turned ON.

The parameter number outside the range can be stored in the error details.

6.4.1 Basic parameter

Symbol	Buffer memory address	Items	Details	Setting range	Fetch timing	Factory default	Unit
Pr.0	0+100n 1+100n	Electronic gear numerator (AP)	Set a numerator of electronic gear applied to position command.	1 to 32768	PLC READY ON (First time only)	1	—
Pr.2	2+100n 3+100n	Electronic gear denominator (AL)	Set a denominator of electronic gear applied to position command.	1 to 32768		1	—
Pr.4	4+100n 5+100n	Software stroke limit upper limit value	Set the upper limit value for software stroke limit.	-2147483648 to 2147483647		2000000000	[PLS]
Pr.6	6+100n 7+100n	Software stroke limit lower limit value	Set the lower limit value for software stroke limit.	-2147483648 to 2147483647		-2000000000	[PLS]
Pr.8	8+100n	Backlash compensation amount	Set the backlash compensation amount. Set it by the encoder pulse unit.	0 to 65535	PLC READY ON/ Parameter change request	0	[PLS]
Pr.10	10+100n 11+100n	Speed limit value	Set the maximum speed for each axis.	1 to 2147		10	$\times 10^6$ [PLS/s]
Pr.15	15+100n	Acceleration/ deceleration method	Select the acceleration/deceleration method.	0: Linear acceleration/ deceleration 1: S-curve acceleration/ deceleration		0	—
Pr.16	16+100n	S-curve acceleration/ deceleration time constant	Set the time constant for S-curve acceleration/deceleration.	0 to 100		0	[ms]
Pr.17	17+100n	Sudden stop deceleration time	Set the deceleration time to execute a sudden stop.	0 to 20000		1000	[ms]
Pr.20	20+100n 21+100n	Command in-position range	Set the remaining distance that turns the command in-position ON.	0 to 2147483647		0	[PLS]
Pr.23	23+100n	Target position change overrun processing selection	Set the process when a stop position exceeds a command position for position change.	0: Stop by the error 1: Return to change position after deceleration stop		0	—

Symbol	Buffer memory address	Items	Details	Setting range	Fetch timing	Factory default	Unit								
Pr.25	25+100n	Interpolation group	<p>Set the group to specify the combination for axes to be interpolation-controlled.</p> <p>Set the same group number for axes to be interpolation-controlled.</p> <ul style="list-style-type: none"> • Up to 4 axes can be set to one group. • Up to 4 groups can be set. 	<p>0: None (Single axis)</p> <p>1: Group 1</p> <p>2: Group 2</p> <p>3: Group 3</p> <p>4: Group 4</p>	PLC READY ON	0	—								
Pr.26	26+100n 27+100n	Linear interpolation speed limit value	Set the maximum speed at the linear interpolation control.	1 to 2147	PLC READY ON/ Parameter change request	10	×10 ⁶ [PLS/s]								
Pr.31	31+100n	External input signal logic selection	<p>Select the logic of the external input signal.</p> <table border="1" style="margin-left: 20px;"> <tr> <td>b15 to b12</td> <td>b11 to b8</td> <td>b7 to b4</td> <td>b3 to b0</td> </tr> <tr> <td>0</td> <td>0</td> <td>0</td> <td>0</td> </tr> </table> <p>b8: Proximity dog</p> <p>b4: Lower hardware strok limit</p> <p>b0: Upper hardware strok limit</p> <p>(Note): Set to "0" for except the above bits.</p>	b15 to b12	b11 to b8	b7 to b4	b3 to b0	0	0	0	0	<p>0: Negative logic</p> <p>1: Positive logic</p>	PLC READY ON	0	—
b15 to b12	b11 to b8	b7 to b4	b3 to b0												
0	0	0	0												

6.4.2 OPR parameter

(1) OPR parameter

Symbol	Buffer memory address	Items	Details	Setting range	Fetch timing	Factory default	Unit
Pr.50	50+100n	OPR method	Select the OPR method.	0: Proximity dog 2: Data set 3: Stopper 4: Dog cradle 5: Limit switch combined 6: Scale origin signal detection	PLC READY ON (First time only)	0	—
Pr.51	51+100n	OPR direction	Set the direction to execute the OPR for proximity dog or the movement direction at the creep speed movement.	0: Positive direction (Address increment direction) 1: Negative direction (Address decrement direction)		0	—
Pr.52	52+100n 53+100n	OP address	Set the OP address at the OPR completion.	-2147483648 to 2147483647	PLC READY ON/ Parameter change request	0	[PLS]
Pr.54	54+100n 55+100n	OPR speed	Set the movement speed for OPR.	5 to 2147000000		5	[PLS/s]
Pr.56	56+100n	Creep speed	Set the creep speed after proximity dog ON (the low speed just before stopping after decelerating from the OPR speed).	5 to 32767		5	[PLS/s]
Pr.58	58+100n	OPR acceleration time	Set the acceleration time at the OPR.	0 to 20000		1000	[ms]
Pr.59	59+100n	OPR deceleration time	Set the deceleration at the OPR.	0 to 20000		1000	[ms]
Pr.60	60+100n 61+100n	OP shift amount	Set the shift amount at the OP shift.	-2147483648 to 2147483647		0	[PLS]
Pr.62	62+100n 63+100n	OP search limit	Set the limit on the movement amount at the OP search movement. If "0" is set, this function does not operate.	0 to 2147000000		0	[PLS]
Pr.66	66+100n	Operation setting for incompleteness of OPR	Set whether the positioning control is executed or not (When the "OPR request (<u>Md.9</u>) Status 1: b0" is ON.).	0: Not executed 1: Executed	PLC READY ON	0	—

(2) OPR parameter (MR-J3-□B-RJ004 use)

Symbol	Buffer memory address	Items	Details	Setting range	Fetch timing	Factory default	Unit
Pr.64	64+100n	Incremental linear scale setting	Set whether the incremental linear scale is used for OPR (except scale origin signal detection type). Set to "0: Need to pass motor Z pause after the power supply is switch on" in "[Pr.397] Function selection C-4".	1: Used Except 1: Not used	PLC READY ON (First time only)	0	—

Refer to the servo amplifier instruction manual.

Servo amplifier type	Instruction manual name
MR-J3-□B-RJ004	SSCNETⅢ Compatible Linear Servo MR-J3-□B-RJ004U□ Instruction Manual (SH-030054)

6.4.3 Manual control parameter

Symbol	Buffer memory address	Items	Details	Setting range	Fetch timing	Factory default	Unit
Pr.80	80+100n 81+100n	JOG speed	Set the speed for JOG operation.	5 to 2147000000	Leading edge of the forward rotation JOG/ Reverse rotation JOG start	0	[PLS/s]
Pr.82	82+100n	JOG operation acceleration time	Set the acceleration time for JOG operation.	0 to 20000		1000	[ms]
Pr.83	83+100n	JOG operation deceleration time	Set the deceleration time for JOG operation.	0 to 20000		1000	[ms]
Pr.84	84+100n 85+100n	Incremental feedrate	Set the feedrate for incremental feed.	0 to 2147483647	Incremental feed start	0	[PLS]

6.4.4 System parameter

Symbol	Buffer memory address	Items	Details	Setting range	Fetch timing	Factory default	Unit
Pr.101	1601	External forced stop selection	Select "Valid/Invalid" of the forced stop input by external 24VDC. (Forced stop input signal [Y2] does not become invalid.) If the value outside setting range is set, the error code 1037 will occur, and it operates considering that it is "0: Valid".	0: Valid 1: Invalid	PLC READY ON	1	—

6.5 Monitor Data

6.5.1 Axis monitor data

(1) Axis monitor data

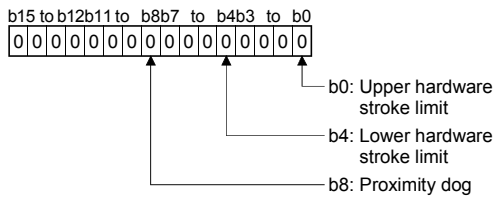
Symbol	Buffer memory address	Items	Details	Updated cycle	Unit
Md.0	1700+100n 1701+100n	Current feed value	The currently commanded address can be stored. When the current value is changed with the current value change function, the changed value can be stored. (It returns to the address before change by the system power supply ON/OFF.)	0.88[ms]	[PLS]
Md.2	1702+100n 1703+100n	Feedrate	The command output speed of operating axis can be stored. The command speed of each axis at the interpolation operation. (A feedrate calculated from movement amount for every axis can be stored. The movement amount might not steady at the fixed speed either because of the fractions generated when operating. Therefore, a value different from the speed set in the positioning might be stored.)		[PLS/s]
Md.4	1704+100n	External input signal	The ON/OFF state of the external input signal can be stored. The following items can be stored.  (Note): The state of signal can be stored regardless of a logic selection.		—
Md.5	1705+100n	Positioning data No. being executed	A positioning data No. currently being executed can be stored. "0" can be stored at the except for positioning execution.	—	—
Md.6	1706+100n	Error code	An error code corresponding to error content can be stored at the error detection. Always, a latest error code can be stored. (If new error will occur, the error code can be updated. However, a system error cannot be updated.) An error code can be cleared by setting "1" in "[Cd.0] Axis error reset".	Error occurrence	—
Md.7	1707+100n	Error detail	A number of error details corresponding to error content can be stored at the error detection. (If new error will occur, a detail corresponded to new error can be stored.) An error detail can be cleared by setting "1" in "[Cd.0] Axis error reset".		—
Md.8	1708+100n	Warning code	A warning code corresponding to warning content can be stored at the warning detection. Always, a latest warning code can be stored. (If new warning will occur, the warning code can be updated.) A warning code can be not automatically cleared even if the warning can be released on the servo amplifier side at the warning detection.)		—

Symbol	Buffer memory address	Items	Details	Updated cycle	Unit
Md.9	1709+100n	Status 1	<p>The ON/OFF state of various signals can be stored.</p> <p>b15 to b12 b11 to b8 b7 to b4 b3 to b0</p> <p>0 0 0 0 0 0 0 0 0 0 0 0 0 0 0 0</p> <p>b0: OPR request b1: OPR complete</p>	Status change	—
Md.10	1710+100n	Status 2	<p>The ON/OFF state of various signals can be stored.</p> <p>b15 to b12 b11 to b8 b7 to b4 b3 to b0</p> <p>0 0 0 0 0 0 0 0 0 0 0 0 0 0 0 0</p> <p>b0: Positioning complete b1: Command in-position b2: Pausing b3: Operation complete b8: Speed change READY b9: Acceleration time change READY b10: Deceleration time change READY b11: Target position change READY</p>		—
Md.26	1726+100n 1727+100n	Real current value	The real current value can be stored.	0.88[ms]	[PLS]
Md.28	1728+100n 1729+100n	Deviation counter value	The difference between the feed current value and real current value can be stored.		[PLS]
Md.31	1731+100n	Motor current	The motor current can be stored.		10 ⁻¹ [%]
Md.32	1732+100n 1733+100n	Motor rotation speed	The motor rotation speed can be stored.		10 ⁻² [r/min]
Md.34	1734+100n	Regenerative load ratio	The rate of regenerative power to the allowable regenerative power can be stored.		[%]
Md.35	1735+100n	Effective load torque ratio	The effective load torque can be stored. The average value of the load rates for the past 15 seconds to the rated torque can be stored as percentage, rated torque being 100[%].		[%]
Md.36	1736+100n	Peak torque ratio	The maximum torque can be stored. The peak value for the past 15 seconds can be stored, rated torque being 100[%].		[%]
Md.40	1740+100n	Servo status 1	<p>The ON/OFF state of various signals can be stored.</p> <p>b15 to b12 b11 to b8 b7 to b4 b3 to b0</p> <p>b0: READY ON b1: Servo ON b7: Servo error (Servo alarm) b12: In-position b13: Torque limit b14: Absolute position lost b15: Servo warning</p>	—	
Md.41	1741+100n	Servo status 2	<p>The ON/OFF state of various signals can be stored.</p> <p>b15 to b12 b11 to b8 b7 to b4 b3 to b0</p> <p>b0: Zero point pass b3: Zero speed</p>	—	

- (a) Md.0 Current feed value / Md.26 Real current value / Md.28 Deviation counter value / Md.2 Feedrate

The following relations exist between "Md.0 Current feed value", "Md.26 Real current value", "Md.28 Deviation" and "Md.2 Feedrate".

$$\text{Command value to servo amplifier} = \text{Current feed value} \times \frac{\text{Electronic gear numerator}}{\text{Electronic gear denominator}}$$

$$\text{Real current value} = \text{Feedback value} \times \frac{\text{Electronic gear denominator}}{\text{Electronic gear numerator}}$$

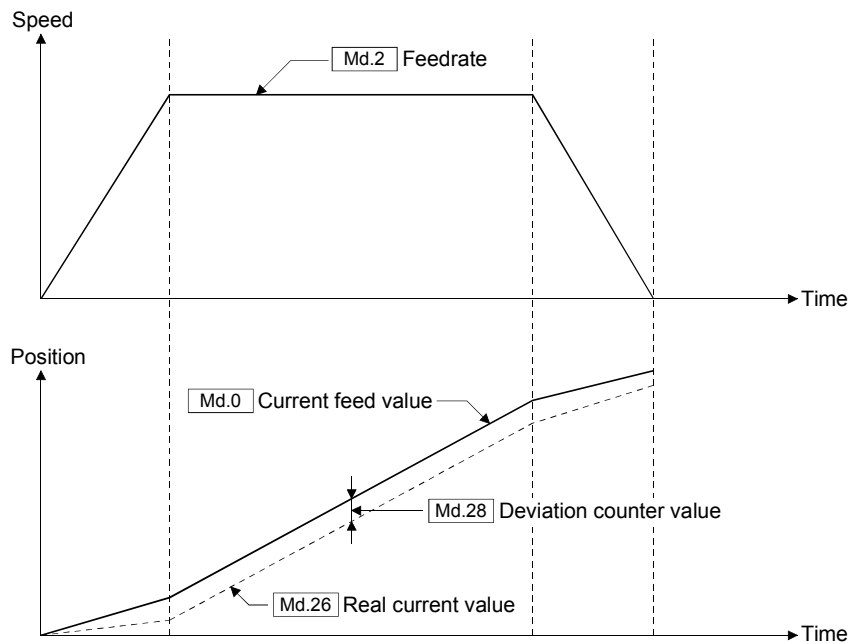

- (b) Md.6 Error code / Md.7 Error detail / Md.100 Axis error status / Error detection signal [X1] / Cd.0 Axis error reset

"Md.6 Error code", "Md.7 Error detail" and "Md.100 Axis error status" are output to the buffer memory if an error will occur, and the error detection signal [X1] is turned ON. The servo errors are also output in a similar way. Remove the error causes and set "1" in "Cd.0 Axis error reset" to release an error.

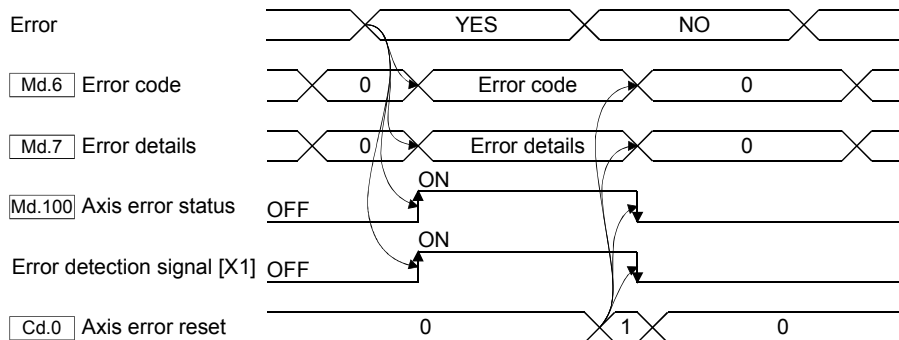

(c) [Md.8] Warning code / [Md.101] Axis warning status / Warning detection signal [X2]

"[Md.8] Warning code" and "[Md.101] Axis warning status" are output to the buffer memory if a warning will occur, and the warning detection signal [X2] is turned ON. The servo warnings are also output in a similar way. Remove the warning causes to release a warning.

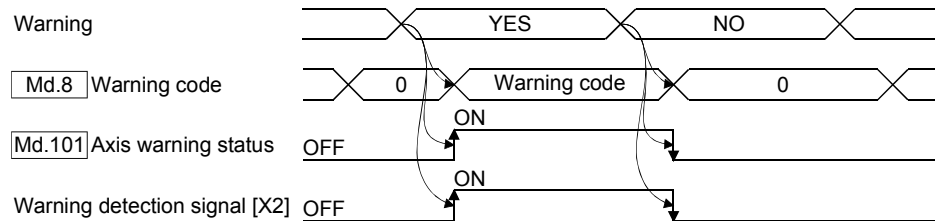

(d) [Md.9] Status 1

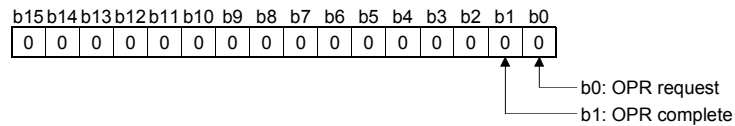

1) b0: OPR request

This signal turns ON when the OPR is required as the following cases, and it turns OFF at OPR completion.

- The electronic gear ("[Pr.0] Electronic gear numerator", "[Pr.2] Electronic gear denominator") or the servo parameter "[Pr.314] Rotation direction selection" are changed. (First PLC READY ON)
- "Error code 2025" or "Warning code 2143" occurred. (First PLC READY ON)
- "Error code 1201" occurred. (First PLC READY ON)
- The OPR never is executed for the absolute position system. (First PLC READY ON)
- Change the servo parameter "[Pr.303] Absolute position detection system" from "0: Invalid (Used in incremental system)" to "1: Valid (Used absolute position detection system)". (First PLC READY ON)
- The OPR is started.
- The setting value of software stroke limit is outside the range. (First PLC READY ON)

2) b1: OPR complete

This signal turns ON at the OPR complete. And, It turns OFF at the positioning start.

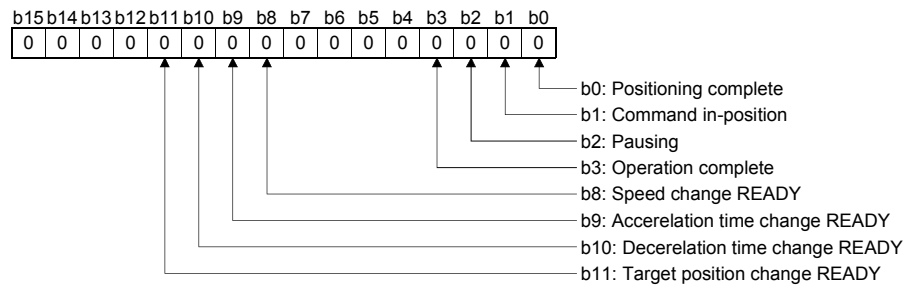
(e) Md.10 Status 2

1) b0: Positioning complete

This signal turns ON at the positioning control (1 axis linear control, Interpolation control) complete.

It turns OFF at the next start (1 axis linear control, Interpolation control, OPR, Manual control).

The BUSY signal [X10 to X1F] OFF and this signal ON can be executed at the same timing.

2) b1: Command in-position

This signal turns ON when the remaining distance is equal to or less than "Pr.20 Command in-position range", and it turns OFF at the positioning control start, OPR start and manual control start.

3) b2: Pausing

This signal turns ON after sudden stop by pausing command. This signal turns OFF by pausing release.

4) b3: Operation complete

This signal turns ON at the positioning completion as the following cases, and it turns OFF at next positioning start.

- After the JOG stop
- After the incremental feed completion
- Positioning control completion (Only the final positioning data completion at execution of the continuous positioning or continuous path control.)
- After the stop by the stop signal
- After the sudden stop by the sudden stop signal
- After the stop by the hardware stroke limit
- Servo alarm occurrence (Not after the stop)
- After the stop by the operation alarm occurrence
- After the stop by the servo OFF
- After the stop by the software stroke limit
- Deceleration by the forced stop (Not after the stop)

The BUSY signal [X10 to X1F] OFF and this signal ON can be executed at the same timing.

- 5) b8: Speed change READY
 This signal turns ON at the ready by setting "1" in "[Cd.15] Speed change request". It does not turn ON if it cannot be changed. (The warning code 11011 will occur.)
 This signal turns OFF by setting "0" in "[Cd.15] Speed change request".
- 6) b9: Acceleration time change READY
 This signal turns ON at the ready by setting "1" is set in "[Cd.18] Acceleration time change request". It does not turn ON if it cannot be changed. (The warning code 11012 will occur.)
 This signal turns OFF by setting "0" in "[Cd.18] Acceleration time change request".
- 7) b10: Deceleration time change READY
 This signal turns ON at the ready by setting "1" is set in "[Cd.20] Deceleration time change request". It does not turn ON if it cannot be changed. (The warning code 11013 will occur.)
 This signal turns OFF by setting "0" in "[Cd.20] Deceleration time change request".
- 8) b11: Target position change READY
 This signal turns ON at the ready by setting "1" is set in "[Cd.23] Target position change request". It does not turn ON if it cannot be changed. (The warning code 11014 will occur.)
 This signal turns OFF by setting "0" in "[Cd.23] Target position change request".

(f) [Md.40] Servo status 1

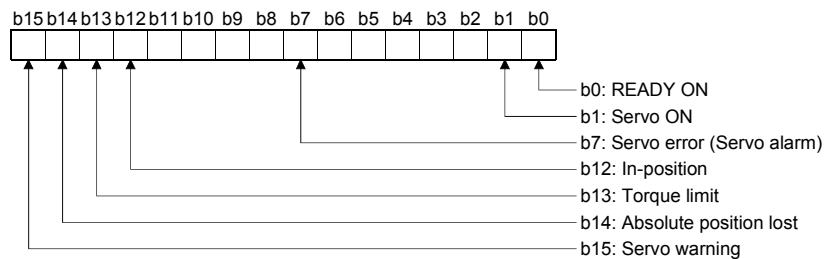

- 1) b0: READY ON
 The servo READY ON/OFF status is indicated.
- 2) b1: Servo ON
 The servo ON/OFF status is indicated.
- 3) b7: Servo error (Servo alarm)
 This signal turns ON in the servo error occurrence.
- 4) b12: In-position
 The dwell pulse turns ON within the servo parameter "[Pr.310] In-position range".
- 5) b13: Torque limit
 This signal turns ON when the servo amplifier is having the torque restricted.

- 6) b14: Absolute position lost
This signal turns ON in "Error code 2025" and "Warning code 2143" occurrence.
- 7) b15: Servo warning
This signal turns ON in servo warning occurrence.

(f) Md.41 Servo status 2

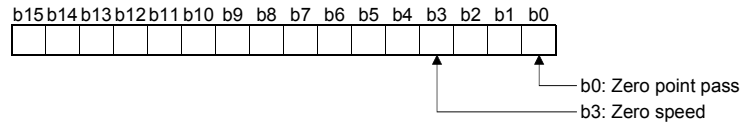

- 1) b0: Zero point pass
This signal turns ON if the zero point of the encoder has been passed even once.
- 2) b3: Zero speed
This signal turns ON when the motor speed is lower than the servo parameter "Pr.387 Zero speed".

(2) Axis monitor data (MR-J3-□B-RJ006 use)

Symbol	Buffer memory address	Items	Details	Updated cycle	Unit
Md.40	1740+100n	Servo status 1	b5: The switching status of the semi closed loop control/ fully closed loop control can be stored. b15 to b12 b11 to b8 b7 to b4 b3 to b0 <p style="margin-left: 400px;">b0: Fully closed loop control switching 0: In semi closed loop control 1: In fully closed loop control</p>	0.88[ms]	—

Refer to the servo amplifier instruction manual.

Servo amplifier type	Instruction manual name
MR-J3-□B-RJ006	SSCNETⅢ Fully Closed Loop Control MR-J3-□B-RJ006 Servo Amplifier Instruction Manual (SH-030056)

6.5.2 System monitor data

(1) System monitor data

Symbol	Buffer memory address	Items	Details	Updated cycle	Unit
Md.100	3300	Axis error status	<p>The bits corresponding to the axis that caused the error can be stored at the error occurrence. The error status for the axis can be turned OFF by error reset for every axis.</p> <p>b15 to b12 b11 to b8 b7 to b4 b3 to b0</p> <p>0 0 0 0 0 0 0 0 0 0 0 0 0 0 0 0</p> <p>b0 : Axis 1 b1 : Axis 2 b2 : Axis 3 b3 : Axis 4 b4 : Axis 5 b5 : Axis 6 b6 : Axis 7 b7 : Axis 8 b8 : Axis 9 b9 : Axis 10 b10 : Axis 11 b11 : Axis 12 b12 : Axis 13 b13 : Axis 14 b14 : Axis 15 b15 : Axis 16</p>	Status change (Error occurrence, Error reset)	—
Md.101	3301	Axis warning status	<p>The bits corresponding to the axis in which the warning occurred can be stored at the warning occurrence. The warning status for the axis can be turned OFF by the warning release.</p> <p>b15 to b12 b11 to b8 b7 to b4 b3 to b0</p> <p>0 0 0 0 0 0 0 0 0 0 0 0 0 0 0 0</p> <p>b0 : Axis 1 b1 : Axis 2 b2 : Axis 3 b3 : Axis 4 b4 : Axis 5 b5 : Axis 6 b6 : Axis 7 b7 : Axis 8 b8 : Axis 9 b9 : Axis 10 b10 : Axis 11 b11 : Axis 12 b12 : Axis 13 b13 : Axis 14 b14 : Axis 15 b15 : Axis 16</p>	Status change (Warning occurrence, Error reset)	—
Md.102	3302	Number of write accesses to flash ROM	Number of write accesses to flash ROM and the number of parameter initializations after the system power supply ON can be stored.	Write request	—
Md.103	3303	Forced stop input status	<p>The status of the forced stop input can be stored. (The status of forced stop input by external 24VDC and the forced stop input signal [Y2] with input signal from PLC CPU can be stored.) 0: Forced stop 1: Forced stop release</p>	0.88[ms]	—

6.6 Control Data

6.6.1 Axis control data

(1) Axis control data

Symbol	Buffer memory address	Items	Details	Setting range	Fetch timing	Factory default	Unit
Cd.0	3400+100n	Axis error reset	<p>Release error that occurs in axis.</p> <ul style="list-style-type: none"> • Clear the error detection signal [X1], "[Md.6] Error code" and "[Md.7] Error detail". • Turn the bit of "[Md.100] Axis error status" OFF for target axis. • Transmit the error reset on servo amplifier side. (The error reset cannot be executed for some servo errors. Refer to the servo amplifier instruction manuals for details.) • Clear the warning detection signal [X2] and "[Md.8] Warning code". • Turn the bit of "[Md.101] Axis warning status" OFF for target axis. 	0: Not commanded 1: Commanded (Leading edge only)	Main cycle (Note-1)	0	—
Cd.1	3401+100n	Parameter change request	Execute the parameter change request when the fetch timing of the basic parameter or OPR parameter is set to "parameter change request".	0: Not requested 1: Requested (Note): "0" can be automatically set after the change of parameter.		0	—
Cd.2	3402+100n	Start method	Set the start method.	1 to 32: Positioning data No. to be started. 9000: OPR 9003: New current value	Leading edge of the positioning start signal [Y10 to Y1F]	0	—
Cd.3	3403+100n	Axis stop	Stop the operating axis.	0: Not commanded 1: Commanded	0.88[ms]	0	—
Cd.4	3404+100n	Axis sudden stop	Stop the operating axis suddenly.	0: Not commanded 1: Commanded		0	—
Cd.5	3405+100n	Pausing	Command the pausing.	0: Pausing release 1: Pausing		0	—
Cd.8	3408+100n	Forward rotation JOG start	Start the forward rotation JOG.	0: Stop 1: Start		0	—
Cd.9	3409+100n	Reverse rotation JOG start	Start the reverse rotation JOG.	0: Stop 1: Start		0	—
Cd.11	3411+100n	Torque limit request	Command the torque limit request.	0: Not requested 1: Requested	0	—	

(Note-1): Cycle of processing executed at free time except the positioning control. It changes by status of axis start.

Symbol	Buffer memory address	Items	Details	Setting range	Fetch timing	Factory default	Unit
Cd.12	3412+100n	Forward rotation torque limit value	Set the limiting torque generated in the CW direction when the servo motor is executing in the CCW direction.	0 to 32767 (Note): It is treated as "0" if the negative value is set.	Torque limit request, For every 0.88[ms]	0	10^{-1} [%]
Cd.13	3413+100n	Reverse rotation torque limit value	Set the limiting torque generated in the CCW direction when the servo motor is executing in the CW direction.			0	10^{-1} [%]
Cd.15	3415+100n	Speed change request	Execute the speed change request.	0: Not requested 1: Requested	0.88[ms]	0	—
Cd.16	3416+100n 3417+100n	New speed value	Set the speed after the change.	5 to 2147000000	Speed change request	0	[PLS/s]
Cd.18	3418+100n	Acceleration time change request	Execute the acceleration time change request.	0: Not requested 1: Requested	0.88[ms]	0	—
Cd.19	3419+100n	New acceleration time value	Set the acceleration time after the change.	0 to 20000	Acceleration time change request	0	[ms]
Cd.20	3420+100n	Deceleration time change request	Execute the deceleration time change request.	0: Not requested 1: Requested	0.88[ms]	0	—
Cd.21	3421+100n	New deceleration time value	Set the deceleration time after the change.	0 to 20000	Deceleration time change request	0	[ms]
Cd.23	3423+100n	Target position change request	Execute the target position change request.	0: Not requested 1: Requested	0.88[ms]	0	—
Cd.24	3424+100n 3425+100n	New target position value	Set the target position after the change.	-2147483648 to 2147483647	Target position change request	0	[PLS]
Cd.28	3428+100n 3429+100n	New current value	Set the address after change.		New current value start	0	
Cd.30	3430+100n	Each axis servo OFF	Execute the servo ON/OFF for each axis.	0: Not commanded 1: Commanded	0.88[ms]	0	—
Cd.46	3446+100n	Gain changing request	Execute the gain changing of the servo amplifier from QD74MH. Refer to the servo amplifier instruction manual.	0: Not requested 1: Requested		0	—

(2) Axis control data (MR-J3-□B-RJ006 use)

Symbol	Buffer memory address	Items	Details	Setting range	Fetch timing	Factory default	Unit
Cd.45	3445+100n	Semi/Fully closed loop switching request	Execute the sSemi/Fully closed loop switching request.	0: Semi closed loop control 1: Fully closed loop control	0.88[ms]	0	—

(Note): The above command is enable when "1" is set to "[Pr.445] (PE01) Fully closed loop selection 1".

Refer to the servo amplifier instruction manual.

Servo amplifier type	Instruction manual name
MR-J3-□B-RJ006	SSCNETⅢ Fully Closed Loop Control MR-J3-□B-RJ006 Servo Amplifier Instruction Manual (SH-030056)

6.6.2 System control data

(1) System control data

Symbol	Buffer memory address	Items	Details	Setting range	Fetch timing	Factory default
Cd.100	5000	Flash ROM write request	Write the contents (Basic parameters, OPR parameters, Manual control parameters, System parameters, Positioning data and servo parameters) from the buffer memory to the flash ROM.	0: Not requested 1: Requested (Note): "0" can be automatically stored after the writing completion.	Main cycle (Note-1)	0
Cd.101	5001	Parameter initialization request	Execute the parameter (Basic parameters, OPR parameters, Manual control parameters, System parameters, Positioning data and servo parameters) initialization request stored in the flash ROM. (Note): Initialization The setting data can be returned to the factory default.	0: Not requested 1: Requested (Note): "0" can be automatically stored after the initialization completion. (Also, "0" can be stored at the initialization error occurrence.)		0

(Note-1): Cycle of processing executed at free time except the positioning control. It changes by status of axis start.

- (a) **[Cd.100]** Flash ROM write request / **[Md.102]** Number of write accesses to flash ROM

Set "1" in "**[Cd.100]** Flash ROM write request" in the state of the PLC READY signal [Y0] OFF. 1 is added to "**[Md.102]** Number of write accesses to flash ROM", and the value can be wrote to the flash ROM. "0" can be automatically set in "**[Cd.100]** Flash ROM write request" with the writing completion.

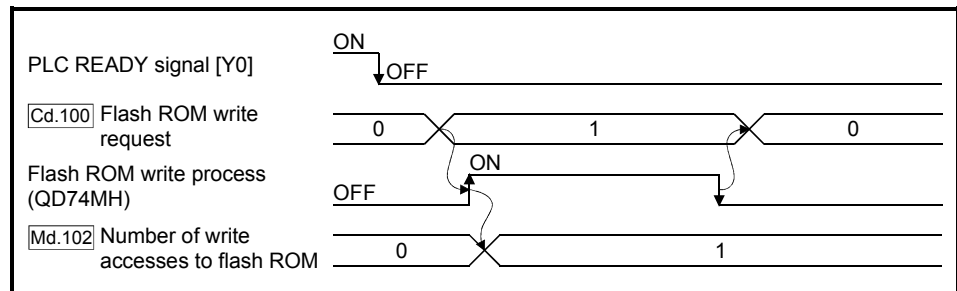

POINT

- (1) Do not turn the system power supply OFF or reset the PLC CPU while writing to the flash ROM. If the system power supply is turned OFF or the PLC CPU is reset to forcibly end the process, the data backed up in the flash ROM will be lost.
- (2) Do not write the data to the buffer memory before writing to the flash ROM is completed.
- (3) The number of the flash ROM write with the sequence program after the single system power supply ON or single PLC CPU reset is limited to up to 25. Writing of the 26th times will cause an "error code 1902".
- (4) The number of writes to the flash ROM after the system power supply ON can be monitored in "**[Md.102]** Number of write accesses to flash ROM".
- (5) The flash ROM write can be executed, after the system's power supply ON and the PLC READY signal [Y0] ON. If the flash ROM write is executed without turning ON the PLC READY signal [Y0] after the system's power supply ON, a "warning code 10001" will occur and the flash ROM write cannot be executed.

(b) [Cd.101] Parameter initialization request

Set "1" in "[Cd.101] Parameter initialization request" in the state of the PLC READY signal [Y0] OFF. Process of the parameter initialization can be executed. "0" can be automatically set in "[Cd.101] Parameter initialization request" with the process completion.

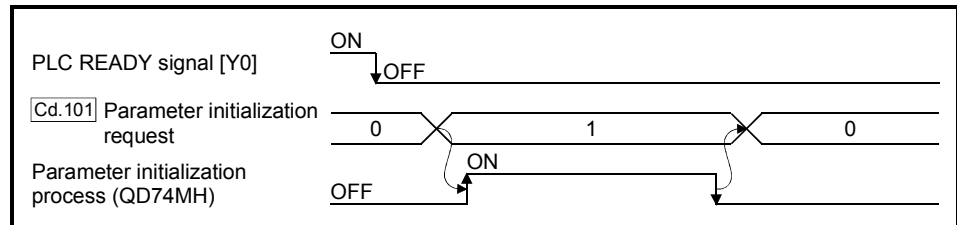

POINT

- (1) Execute the parameter initialization when the positioning control do not execute (PLC READY signal [Y0] OFF). An "error code 1903" will occur if it is executed at the PLC READY signal [Y0] ON.
- (2) A writing to the flash ROM is up to 100,000 times. If writing exceeds 100,000 times, the writing may be become impossible, and an "error code 1901" will occur.
- (3) Be sure to turn the system power supply ON/OFF or reset the PLC CPU after the parameter initialization.
- (4) The number of the flash ROM write with the sequence program after the single system power supply ON or single PLC CPU reset is limited to up to 25. Writing of the 26th times will cause an "error code 1902".
- (5) The number of parameter initialization after the system power supply ON can be monitored in "[Md.102] Number of write accesses to flash ROM".
- (6) The parameter initialization can be executed, after the system's power supply ON and the PLC READY signal [Y0] ON. If the parameter initialization is executed without turning ON the PLC READY signal [Y0] after the system's power supply ON, a "warning code 10001" will occur and the parameter initialization cannot be executed.

6.7 Positioning Data

The positioning data of 32 points can be set for one axis.

The positioning data stored in the buffer memory of QD74MH are shown below.

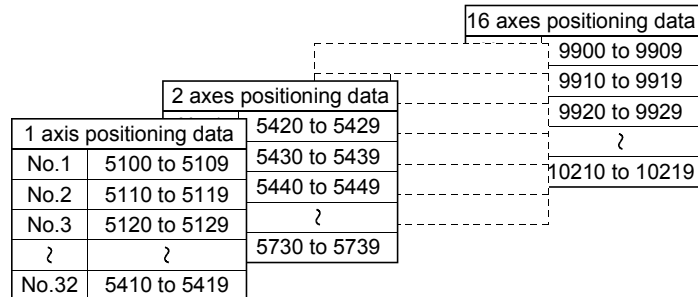

Table 6.9 List of buffer memory for positioning data

Point No.	Buffer memory address															
	Axis 1	Axis 2	Axis 3	Axis 4	Axis 5	Axis 6	Axis 7	Axis 8	Axis 9	Axis 10	Axis 11	Axis 12	Axis 13	Axis 14	Axis 15	Axis 16
No.1	5100 to 5109	5420 to 5429	5740 to 5749	6060 to 6069	6380 to 6389	6700 to 6709	7020 to 7029	7340 to 7349	7660 to 7669	7980 to 7989	8300 to 8309	8620 to 8629	8940 to 8949	9260 to 9269	9580 to 9589	9900 to 9909
No.2	5110 to 5119	5430 to 5439	5750 to 5759	6070 to 6079	6390 to 6399	6710 to 6719	7030 to 7039	7350 to 7359	7670 to 7679	7990 to 7999	8310 to 8319	8630 to 8639	8950 to 8959	9270 to 9279	9590 to 9599	9910 to 9919
No.3	5120 to 5129	5440 to 5449	5760 to 5769	6080 to 6089	6400 to 6409	6720 to 6729	7040 to 7049	7360 to 7369	7680 to 7689	8000 to 8009	8320 to 8329	8640 to 8649	8960 to 8969	9280 to 9289	9600 to 9609	9920 to 9929
to	to															
No.31	5400 to 5409	5720 to 5729	6040 to 6049	6360 to 6369	6680 to 6689	7000 to 7009	7320 to 7329	7640 to 7649	7960 to 7969	8280 to 8289	8600 to 8609	8920 to 8929	9240 to 9249	9560 to 9569	9880 to 9889	10200 to 10209
No.32	5410 to 5419	5730 to 5739	6050 to 6059	6370 to 6379	6690 to 6699	7010 to 7019	7330 to 7339	7650 to 7659	7970 to 7979	8290 to 8299	8610 to 8619	8930 to 8939	9250 to 9259	9570 to 9579	9890 to 9899	10210 to 10219

(1) Positioning data

Symbol	Buffer memory address	Items	Details	Setting range	Fetch timing	Factory default	Unit
Da.0	5100+320n	Operation pattern	Set the operation pattern for the continuous positioning data.	0: Independent positioning (Positioning complete) 1: Continuous positioning 3: Continuous path	Positioning data execution	0	—
Da.1	5101+320n	Control system	Set the positioning control system.	0: ABS linear 1 1: INC linear 1 2: ABS linear interpolation 3: INC linear interpolation		0	—
Da.2	5102+320n	Acceleration time	Set the acceleration time.	0 to 20000		0	[ms]
Da.3	5103+320n	Deceleration time	Set the deceleration time.	0 to 20000		0	[ms]
Da.4	5104+320n 5105+320n	Command speed	Set the positioning speed.	5 to 2147000000		0	[PLS/s]
Da.6	5106+320n 5107+320n	Positioning address/ movement amount	Set the positioning address/movement amount. Set an absolute address in the absolute system, and set a movement amount with sign in the incremental system.	1 axis linear control: -2147483648 to 2147483647 Interpolation control: -999999999 to 999999999		0	[PLS]
Da.8	5108+320n	Dwell time	Set the time from when the positioning data ends to when the positioning completes.	0 to 65535		0	[ms]

6.8 Servo Parameter

Symbol	Buffer memory address	Items	Details	Setting range	Fetch timing	Factory default
Pr.300	10300+300n	Servo series	<p>Set the servo amplifier series connected to QD74MH.</p> <p>POINT</p> <p>Set correctly the servo amplifier series to match the number of axes and axis number to be connected.</p> <p>If the servo amplifier series setting is not corresponding to the actual number of axes, an error will occur and the system cannot be started.</p>	<p>0: None</p> <p>1: MR-J3-B</p> <p>3: MR-J3-B (Fully closed loop control)</p> <p>4: MR-J3-B (Linear)</p>	First PLC READY ON after the system power supply ON	0

Refer to the servo amplifier instruction manual.

Instruction Manual list is shown below.

Servo amplifier type	Instruction manual name
MR-J3-□B	SSCNETⅢ Compatible MR-J3-□B Servo Amplifier Instruction Manual (SH-030051)
MR-J3-□B-RJ004	SSCNETⅢ Compatible Linear Servo MR-J3-□B-RJ004U□ Instruction Manual (SH-030054)
MR-J3-□B-RJ006	SSCNETⅢ Fully Closed Loop Control MR-J3-□B-RJ006 Servo Amplifier Instruction Manual (SH-030056)

POINT

Parameters whose symbol is followed by "*" or "**" become valid as follows. Set the parameter value and transmit the parameter to servo amplifier from QD74MH with the PLC READY ON. And then, once execute the power cycle of servo amplifier to make the parameter setting valid. Refer to Section 6.2.3 for details of change procedure.

(1) Servo parameter (MR-J3-□B use)
 (a) Basic setting parameters

Symbol	Buffer memory address	No.	Symbol	Name	Factory default of QD74MH	Unit	Setting range
Pr.301	10301+300n	PA01	—	For manufacturer setting	0000h	—	0000h to 0230h
Pr.302	10302+300n	PA02	REG**	Regenerative option	0000h	—	0000h to 000Ah
Pr.303	10303+300n	PA03	ABS*	Absolute position detection system	0000h	—	0000h to 0001h
Pr.304	10304+300n	PA04	AOP1*	Function selection A-1	0000h	—	0000h to 0110h
Pr.305	10305+300n	PA05	—	For manufacturer setting	0	—	—
Pr.306	10306+300n	PA06	—		1	—	—
Pr.307	10307+300n	PA07	—		1	—	—
Pr.308	10308+300n	PA08	ATU	Auto tuning mode	0001h	—	0000h to 0003h
Pr.309	10309+300n	PA09	RSP	Auto tuning response	12	—	1 to 32
Pr.310	10310+300n	PA10	INP	In-position range	100	PLS	0 to 50000
Pr.311	10311+300n	PA11	—	For manufacturer setting	10000	—	—
Pr.312	10312+300n	PA12	—		10000	—	—
Pr.313	10313+300n	PA13	—		0000h	—	—
Pr.314	10314+300n	PA14	POL*	Rotation direction selection	0	—	0 to 1
Pr.315	10315+300n	PA15	ENR*	Encoder output pulses	4000	PLS/rev	1 to 65535
Pr.316	10316+300n	PA16	—	For manufacturer setting	0	—	—
Pr.317	10317+300n	PA17	—		0000h	—	—
Pr.318	10318+300n	PA18	—		0000h	—	—
Pr.319	10319+300n	PA19	—		000Bh	—	0000h to FFFFh

(b) Gain/filter parameters

Symbol	Buffer memory address	No.	Symbol	Name	Factory default of QD74MH	Unit	Setting range
Pr.333	10333+300n	PB01	FILT	Adaptive tuning mode (Adaptive filter II)	0000h	—	0000h to 0002h
Pr.334	10334+300n	PB02	VRFT	Vibration suppression control tuning mode (Advanced vibration suppression control)	0000h	—	0000h to 0002h
Pr.335	10335+300n	PB03	—	For manufacturer setting	0	—	—
Pr.336	10336+300n	PB04	FFC	Feed forward gain	0	%	0 to 100
Pr.337	10337+300n	PB05	—	For manufacturer setting	500	—	—
Pr.338	10338+300n	PB06	CD2	Ratio of load inertia moment to servo motor inertia moment	70	$\times 10^{-1}$ times	0 to 3000
Pr.339	10339+300n	PB07	PG1	Model loop gain	24	rad/s	1 to 2000
Pr.340	10340+300n	PB08	PG2	Position loop gain	37	rad/s	1 to 1000
Pr.341	10341+300n	PB09	VG2	Speed loop gain	823	rad/s	20 to 50000
Pr.342	10342+300n	PB10	VIC	Speed integral compensation	337	$\times 10^{-1}$ ms	1 to 10000
Pr.343	10343+300n	PB11	VDC	Speed differential compensation	980	—	0 to 1000
Pr.344	10344+300n	PB12	—	For manufacturer setting	0	—	—
Pr.345	10345+300n	PB13	NH1	Machine resonance suppression filter 1	4500	Hz	100 to 4500
Pr.346	10346+300n	PB14	NHQ1	Notch shape selection 1	0000h	—	0000h to 0330h
Pr.347	10347+300n	PB15	NH2	Machine resonance suppression filter 2	4500	Hz	100 to 4500
Pr.348	10348+300n	PB16	NHQ2	Notch shape selection 2	0000h	—	0000h to 0331h
Pr.349	10349+300n	PB17	—	Automatic setting parameter	—	—	0000h to 031Fh
Pr.350	10350+300n	PB18	LPF	Low-pass filter setting	3141	Hz	100 to 18000
Pr.351	10351+300n	PB19	VRF1	Vibration suppression control vibration frequency setting	1000	$\times 10^{-1}$ Hz	1 to 1000
Pr.352	10352+300n	PB20	VRF2	Vibration suppression control resonance frequency setting	1000	$\times 10^{-1}$ Hz	1 to 1000
Pr.353	10353+300n	PB21	—	For manufacturer setting	0	—	—
Pr.354	10354+300n	PB22	—		0	—	—
Pr.355	10355+300n	PB23	VFBF	Low-pass filter selection	0000h	—	0000h to 0011h
Pr.356	10356+300n	PB24	MVS*	Slight vibration suppression control selection	0000h	—	0000h to 0031h
Pr.357	10357+300n	PB25	—	For manufacturer setting	0000h	—	—
Pr.358	10358+300n	PB26	CDP*	Gain changing selection	0000h	—	0000h to 0014h
Pr.359	10359+300n	PB27	CDL	Gain changing condition	10	—	0 to 9999
Pr.360	10360+300n	PB28	CDT	Gain changing time constant	1	ms	0 to 100
Pr.361	10361+300n	PB29	GD2B	Gain changing ratio of load inertia moment to servomotor inertia moment	70	$\times 10^{-1}$ times	0 to 3000
Pr.362	10362+300n	PB30	PG2B	Gain changing position loop gain	37	rad/s	1 to 2000
Pr.363	10363+300n	PB31	VG2B	Gain changing speed loop gain	823	rad/s	20 to 50000
Pr.364	10364+300n	PB32	VICB	Gain changing speed integral compensation	337	$\times 10^{-1}$ ms	1 to 50000
Pr.365	10365+300n	PB33	VRF1B	Gain changing vibration suppression control vibration frequency setting	1000	$\times 10^{-1}$ Hz	1 to 1000
Pr.366	10366+300n	PB34	VRF2B	Gain changing vibration suppression control resonance frequency setting	1000	$\times 10^{-1}$ Hz	1 to 1000
Pr.367	10367+300n	PB35	—	For manufacturer setting	0	—	—
Pr.368	10368+300n	PB36	—		0	—	—
Pr.369	10369+300n	PB37	—		100	—	—
Pr.370	10370+300n	PB38	—		0	—	—
Pr.371	10371+300n	PB39	—		0	—	—
Pr.372	10372+300n	PB40	—		0	—	—
Pr.373	10373+300n	PB41	—		1125	—	—
Pr.374	10374+300n	PB42	—		1125	—	—
Pr.375	10375+300n	PB43	—		0004h	—	—
Pr.376	10376+300n	PB44	—		0	—	—
Pr.377	10377+300n	PB45	—		0000h	—	—

(c) Expansion setting parameters

Symbol	Buffer memory address	No.	Symbol	Name	Factory default of QD74MH	Unit	Setting range
Pr.381	10381+300n	PC01	ERZ*	Error excessive alarm level	3	rev	1 to 200
Pr.382	10382+300n	PC02	MBR	Electromagnetic brake sequence output	0	ms	0 to 1000
Pr.383	10383+300n	PC03	ENRS*	Encoder output pulses selection	0000h	—	0000h to 0021h
Pr.384	10384+300n	PC04	COP1**	Function selection C-1	0000h	—	0000h to 1110h
Pr.385	10385+300n	PC05	COP2**	Function selection C-2	0000h	—	0000h to 1110h
Pr.386	10386+300n	PC06	COP3**	Function selection C-3	0000h	—	0000h to 3021h
Pr.387	10387+300n	PC07	ZSP	Zero speed	50	r/min	0 to 10000
Pr.388	10388+300n	PC08	—	For manufacturer setting	0	—	—
Pr.389	10389+300n	PC09	MOD1	Analog monitor 1 output	0000h	—	0000h to 041Fh
Pr.390	10390+300n	PC10	MOD2	Analog monitor 2 output	0001h	—	0000h to 041Fh
Pr.391	10391+300n	PC11	MO1	Analog monitor 1 offset	0	mV	-999 to 999
Pr.392	10392+300n	PC12	MO2	Analog monitor 2 offset	0	mV	-999 to 999
Pr.393	10393+300n	PC13	MOSDL	Analog monitor feedback position output standard data Low	0	PLS	-9999 to 9999
Pr.394	10394+300n	PC14	MOSDH	Analog monitor feedback position output standard data High	0	10000PLS	-9999 to 9999
Pr.395	10395+300n	PC15	—	For manufacturer setting	0	—	—
Pr.396	10396+300n	PC16	—		0000h	—	—
Pr.397	10397+300n	PC17	COP4**	Function selection C-4	0000h	—	0000h to 0001h
Pr.398	10398+300n	PC18	—	For manufacturer setting	0000h	—	—
Pr.399	10399+300n	PC19	—		0000h	—	—
Pr.400	10400+300n	PC20	—		0000h	—	—
Pr.401	10401+300n	PC21	—	Alarm history clear	0000h	—	0000h to 0001h
Pr.402	10402+300n	PC22	—	For manufacturer setting	0000h	—	—
Pr.403	10403+300n	PC23	—		0000h	—	—
Pr.404	10404+300n	PC24	—		0000h	—	—
Pr.405	10405+300n	PC25	—		0000h	—	—
Pr.406	10406+300n	PC26	—		0000h	—	—
Pr.407	10407+300n	PC27	—		0000h	—	—
Pr.408	10408+300n	PC28	—		0000h	—	—
Pr.409	10409+300n	PC29	—		0000h	—	—
Pr.410	10410+300n	PC30	—		0000h	—	—
Pr.411	10411+300n	PC31	—		0000h	—	—
Pr.412	10412+300n	PC32	—		0000h	—	—

(d) I/O setting parameters

Symbol	Buffer memory address	No.	Symbol	Name	Factory default of QD74MH	Unit	Setting range
Pr.413	10413+300n	PD01	—	For manufacturer setting	0000h	—	—
Pr.414	10414+300n	PD02	—		0000h	—	—
Pr.415	10415+300n	PD03	—		0000h	—	—
Pr.416	10416+300n	PD04	—		0000h	—	—
Pr.417	10417+300n	PD05	—		0000h	—	—
Pr.418	10418+300n	PD06	—		0000h	—	—
Pr.419	10419+300n	PD07	DO1*	Output signal device selection 1	0005h	—	0000h to 003Fh
Pr.420	10420+300n	PD08	DO2*	Output signal device selection 2	0004h	—	0000h to 003Fh
Pr.421	10421+300n	PD09	DO3*	Output signal device selection 3	0003h	—	0000h to 003Fh
Pr.422	10422+300n	PD10	—	For manufacturer setting	0000h	—	—
Pr.423	10423+300n	PD11	—		0004h	—	—
Pr.424	10424+300n	PD12	—		0000h	—	—
Pr.425	10425+300n	PD13	—		0000h	—	—
Pr.426	10426+300n	PD14	DOP3*	Function selection D-3	0000h	—	0000h to 0100h
Pr.427	10427+300n	PD15	—	For manufacturer setting	0000h	—	—
Pr.428	10428+300n	PD16	—		0000h	—	—
Pr.429	10429+300n	PD17	—		0000h	—	—
Pr.430	10430+300n	PD18	—		0000h	—	—
Pr.431	10431+300n	PD19	—		0000h	—	—
Pr.432	10432+300n	PD20	—		0000h	—	—
Pr.433	10433+300n	PD21	—		0000h	—	—
Pr.434	10434+300n	PD22	—		0000h	—	—
Pr.435	10435+300n	PD23	—		0000h	—	—
Pr.436	10436+300n	PD24	—		0000h	—	—
Pr.437	10437+300n	PD25	—		0000h	—	—
Pr.438	10438+300n	PD26	—		0000h	—	—
Pr.439	10439+300n	PD27	—		0000h	—	—
Pr.440	10440+300n	PD28	—		0000h	—	—
Pr.441	10441+300n	PD29	—		0000h	—	—
Pr.442	10442+300n	PD30	—		0000h	—	—
Pr.443	10443+300n	PD31	—		0000h	—	—
Pr.444	10444+300n	PD32	—		0000h	—	—

(e) Extension control parameters

Symbol	Buffer memory address	No.	Symbol	Name	Factory default of QD74MH	Unit	Setting range
Pr.445	10445+300n	PE01	—	For manufacturer setting	0000h	—	—
Pr.446	10446+300n	PE02	—		0102h	—	—
Pr.447	10447+300n	PE03	—		0002h	—	—
Pr.448	10448+300n	PE04	—		1	—	—
Pr.449	10449+300n	PE05	—		1	—	—
Pr.450	10450+300n	PE06	—		400	—	—
Pr.451	10451+300n	PE07	—		100	—	—
Pr.452	10452+300n	PE08	—		10	—	—
Pr.453	10453+300n	PE09	—		0000h	—	—
Pr.454	10454+300n	PE10	—		0000h	—	—
Pr.455	10455+300n	PE11	—		0	—	—
Pr.456	10456+300n	PE12	—		40	—	—
Pr.457	10457+300n	PE13	—		FFFEh	—	—
Pr.458	10458+300n	PE14	—		0111h	—	—
Pr.459	10459+300n	PE15	—		20	—	—
Pr.460	10460+300n	PE16	—		0000h	—	—
Pr.461	10461+300n	PE17	—		0000h	—	—
Pr.462	10462+300n	PE18	—		0000h	—	—
Pr.463	10463+300n	PE19	—		0000h	—	—
Pr.464	10464+300n	PE20	—		0000h	—	—
Pr.465	10465+300n	PE21	—		0000h	—	—
Pr.466	10466+300n	PE22	—		0000h	—	—
Pr.467	10467+300n	PE23	—		0000h	—	—
Pr.468	10468+300n	PE24	—		0000h	—	—
Pr.469	10469+300n	PE25	—		0000h	—	—
Pr.470	10470+300n	PE26	IIRC21	Filter coefficient 2-1	0000h	—	0000h to FFFFh
Pr.471	10471+300n	PE27	IIRC22	Filter coefficient 2-2	0000h	—	0000h to FFFFh
Pr.472	10472+300n	PE28	IIRC23	Filter coefficient 2-3	0000h	—	0000h to FFFFh
Pr.473	10473+300n	PE29	IIRC24	Filter coefficient 2-4	0000h	—	0000h to FFFFh
Pr.474	10474+300n	PE30	IIRC25	Filter coefficient 2-5	0000h	—	0000h to FFFFh
Pr.475	10475+300n	PE31	IIRC26	Filter coefficient 2-6	0000h	—	0000h to FFFFh
Pr.476	10476+300n	PE32	IIRC27	Filter coefficient 2-7	0000h	—	0000h to FFFFh
Pr.477	10477+300n	PE33	IIRC28	Filter coefficient 2-8	0000h	—	0000h to FFFFh
Pr.478	10478+300n	PE34	—	For manufacturer setting	0	—	—
Pr.479	10479+300n	PE35	—		0	—	—
Pr.480	10480+300n	PE36	—		0	—	—
Pr.481	10481+300n	PE37	—		0	—	—
Pr.482	10482+300n	PE38	—		0	—	—
Pr.483	10483+300n	PE39	—		0	—	—
Pr.484	10484+300n	PE40	—		0	—	—

(f) Special setting parameters

Symbol	Buffer memory address	No.	Symbol	Name	Factory default of QD74MH	Unit	Setting range
Pr.493	10493+300n	PS01	—	For manufacturer setting	0	—	—
Pr.494	10494+300n	PS02	—		0	—	—
Pr.495	10495+300n	PS03	—		0	—	—
Pr.496	10496+300n	PS04	—		0	—	—
Pr.497	10497+300n	PS05	—		0	—	—
Pr.498	10498+300n	PS06	—		0	—	—
Pr.499	10499+300n	PS07	—		0	—	—
Pr.500	10500+300n	PS08	—		0	—	—
Pr.501	10501+300n	PS09	—		0	—	—
Pr.502	10502+300n	PS10	—		0	—	—
Pr.503	10503+300n	PS11	—		0	—	—
Pr.504	10504+300n	PS12	—		0	—	—
Pr.505	10505+300n	PS13	—		0	—	—
Pr.506	10506+300n	PS14	—		0	—	—
Pr.507	10507+300n	PS15	—		0	—	—
Pr.508	10508+300n	PS16	—		0	—	—
Pr.509	10509+300n	PS17	—		0	—	—
Pr.510	10510+300n	PS18	—		0	—	—
Pr.511	10511+300n	PS19	—		0	—	—
Pr.512	10512+300n	PS20	—		0	—	—
Pr.513	10513+300n	PS21	—		0	—	—
Pr.514	10514+300n	PS22	—		0	—	—
Pr.515	10515+300n	PS23	—		0	—	—
Pr.516	10516+300n	PS24	—		0	—	—
Pr.517	10517+300n	PS25	—		0	—	—
Pr.518	10518+300n	PS26	—		0	—	—
Pr.519	10519+300n	PS27	—		0	—	—
Pr.520	10520+300n	PS28	—		0	—	—
Pr.521	10521+300n	PS29	—		0	—	—
Pr.522	10522+300n	PS30	—		0	—	—
Pr.523	10523+300n	PS31	—		0	—	—
Pr.524	10524+300n	PS32	—		0	—	—

(2) Servo parameters (MR-J3-□B-RJ006 use)

The parameters (refer to this section (1)) used in the MR-J3-□B besides the following parameters are required.

Symbol	Buffer memory address	No.	Symbol	Name	Factory default of QD74MH	Unit	Setting range
Pr.301	10301+300n	PA01	STY**	Control mode	0000h	—	0000h, 0010h
Pr.316	10316+300n	PA16	ENR2*	Encoder output pulses 2	0	—	0 to 65535
Pr.381	10381+300n	PC01	ERZ	Error excessive alarm level	3	rev	1 to 200
Pr.383	10383+300n	PC03	ENRS*	Encoder output pulses selection	0000h	—	0000h to 0131h
Pr.406	10406+300n	PC26	COP8**	Function selection C-8	0000h	—	0100h, 1100h
Pr.407	10407+300n	PC27	COP9**	Function selection C-9	0000h	—	0000h to 0101h
Pr.414	10414+300n	PD02	DIA2*	For manufacturer setting	0000h	—	—
Pr.445	10445+300n	PE01	FCT1**	Fully closed loop selection 1	0000h	—	0000h to 0001h
Pr.447	10447+300n	PE03	FCT2*	Fully closed loop selection 2	0002h	—	0000h, 1013h
Pr.448	10448+300n	PE04	FBN**	Fully closed loop feedback pulse electronic gear numerator 1	1	—	1 to 65535
Pr.449	10449+300n	PE05	FBD**	Fully closed loop feedback pulse electronic gear denominator 1	1	—	1 to 65535
Pr.450	10450+300n	PE06	BC1	Fully closed loop control speed deviation error detection level	400	r/min	1 to 50000
Pr.451	10451+300n	PE07	BC2	Fully closed loop control position deviation error detection level	100	kPLS	1 to 20000
Pr.452	10452+300n	PE08	DUF	Fully closed loop dual feedback filter	10	rad/s	0 to 4500
Pr.454	10454+300n	PE10	FCT3	Fully closed loop selection 3	0000h	—	0000h to 1200h
Pr.478	10478+300n	PE34	FBN2**	Fully closed loop feedback pulse electronic gear numerator 2	0	—	0 to 32767
Pr.479	10479+300n	PE35	FBD2**	Fully closed loop feedback pulse electronic gear denominator 2	0	—	0 to 32767

REMARK

- When using the fully closed loop control system, set "0010h" in "[Pr.301] Control mode".
- When using the fully closed loop control system, the default value of servo amplifier differs from the default value of QD74MH. Set an appropriate value referring to the servo amplifier instruction manual. (The servo amplifier does not operate normally with the default value of QD74MH.)

Refer to the servo amplifier instruction manual for details

Servo amplifier type	Instruction manual name
MR-J3-□B-RJ006	SSCNETⅢ Fully Closed Loop Control MR-J3-□B-RJ006 Servo Amplifier Instruction Manual (SH-030056)

(3) Servo parameter (MR-J3-□B-RJ004 use)

The parameters (refer to this section (1)) used in the MR-J3-□B besides the following parameters are required.

Symbol	Buffer memory address	No.	Symbol	Name	Factory default of QD74MH	Unit	Setting range
Pr.301	10301+300n	PA01	STY**	Control mode	0000h	—	—
Pr.316	10316+300n	PA16	ENR2*	Encoder output pulses 2	0	—	1 to 65535
Pr.381	10381+300n	PC01	ERZ	Error excessive alarm level	3	mm	1 to 1000
Pr.383	10383+300n	PC03	ENRS*	Encoder output pulses selection	0000h	—	0010h to 0031h
Pr.406	10406+300n	PC26	COP8**	Function selection C-8	0000h	—	0100h, 1100h
Pr.407	10407+300n	PC27	COP9**	Function selection C-9	0000h	—	0000h to 0101h
Pr.414	10414+300n	PD02	DIA2*	Input signal automatic ON selection	0000h	—	0000h to 0003h
Pr.493	10493+300n	PS01	LIT1**	Linear function selection 1	0000h	—	0000h to 1601h
Pr.494	10494+300n	PS02	LIM**	Linear encoder resolution setting numerator	0	—	1 to 65535
Pr.495	10495+300n	PS03	LID**	Linear encoder resolution setting denominator	0	—	1 to 65535
Pr.496	10496+300n	PS04	LIT2*	Linear function selection 2	0000h	—	0000h to 1007h
Pr.497	10497+300n	PS05	LB1	Linear servo motor control position deviation error detection level	0	mm	1 to 1000
Pr.498	10498+300n	PS06	LB2	Linear servo motor control speed deviation error detection level	0	mm/s	1 to 5000
Pr.499	10499+300n	PS07	LB3	Linear servo motor control thrust deviation error detection level	0	%	1 to 1000
Pr.500	10500+300n	PS08	LIT3*	Linear function selection 3	0000h	—	0010h to 0012h
Pr.501	10501+300n	PS09	LPWM	Magnetic pole detection voltage level	0	%	0 to 100
Pr.502	10502+300n	PS10	LFH	At magnetic pole detection current detection method Identification signal frequency	0	Hz	1 to 500
Pr.503	10503+300n	PS11	LIDH	At magnetic pole detection current detection method Identification signal amplitude.	0	%	50 to 100
Pr.504	10504+300n	PS12	—	For manufacturer setting	0	—	—

REMARK

- When using the linear servo, set "0040h" in "[Pr.301] Control mode".
- When using the linear servo, the default value of servo amplifier differs from the default value of QD74MH. Set an appropriate value referring to the servo amplifier instruction manual. (The servo amplifier does not operate normally with the default value of QD74MH.)

Refer to the servo amplifier instruction manual.

Servo amplifier type	Instruction manual name
MR-J3-□B-RJ004	SSCNETⅢ Compatible Linear Servo MR-J3-□B-RJ004U□ Instruction Manual (SH-030054)

7. OPR CONTROL

7.1 Outline of OPR Control

In OPR control, a position is established as the starting point when executing positioning control. The six methods of OPR control are shown below.

Through use of any of the methods, the current position becomes the value set in "Pr.52 OP address" at OPR completion, and the "OPR complete (Md.9 Status 1: b1)" turns ON. "OPR complete" turns OFF at the next operation start.

The OPR retry in the negative direction is executed at the hardware stroke limit detection for some OPR methods. Presence/absence of retry is also shown below.

Table 7.1 OPR method list

Method	Details	Retry
Proximity dog type	A method where deceleration being when the proximity dog turns ON and then the OP is defined as the first zero point after the proximity dog turns back OFF.	○
Data set type	A method which uses the JOG operation to move to any arbitrary position and then sets that position as the home position. A proximity dog is unnecessary.	×
Stopper type	To set the OP, first set the torque limit to a value in which the stopper will not be damaged. Next, perform a JOG operation and continue to JOG until the torque limit is reached due to the stopper. The stopper type OPR is now set.	×
Dog cradle type	The dog cradle method performs a deceleration when the proximity dog turns ON. Then, movement direction is reversed until the dog turns back OFF. At this point, movement is again towards the dog sensor but at the set creep speed. As soon as the dog turns back ON again, movement stops and the OP is defined.	○
Limit switch combined type	The limit switch sensor in the opposite direction of the home sensor is used for OPR. This method moves towards the limit switch and beings decelerating when the sensor turns on. Movement then reverses and the home position is the first Z pulse after the sensor turns back off.	×
Scale origin signal detection type	The scale origin signal detection method beings deceleration upon the dog sensor ON. Then, movement is reversed and the system detects for the linear scale's OP signal. Once detected, the system decelerates to a stop and then returns to the scale's OP at the set creep speed.	×

○: Possible ×: Not possible

7.1.1 Data used for control

The parameters and control data used for OPR are shown below.

Refer to Section 6.3 to 6.8 for the buffer memory address and details.

	Symbol	Items	Details
Parameter	Pr.50	OPR method	Select the OPR method.
	Pr.51	OPR direction	Set the direction to execute the OPR.
	Pr.52	OP address	Set the OP address at the OPR completion.
	Pr.54	OPR speed	Set the movement speed for OPR.
	Pr.56	Creep speed	Set the creep speed after proximity dog ON.
	Pr.58	OPR acceleration time	Set the acceleration time at the OPR.
	Pr.59	OPR deceleration time	Set the deceleration at the OPR.
	Pr.60	OP shift amount	Set the shift amount at the OP shift.
	Pr.62	OP search limit	Set the limit on the movement amount at the OP search movement.
Control data	Cd.2	Start method	Set the start method (9000: OPR).

7.1.2 Starting method of OPR

Starting method of OPR is shown below.

- 1) Set the OPR control related parameters as shown Table 7.1.1.
- 2) Set "9000" in "[Cd.2] Start method".
- 3) Turn the positioning start signal [Y10 to Y1F] ON.
- 4) "OPR request ([Md.9] Status 1: b0)" is turned OFF with the OPR completion, and "OPR complete ([Md.9] Status 1: b1)" is turned ON.

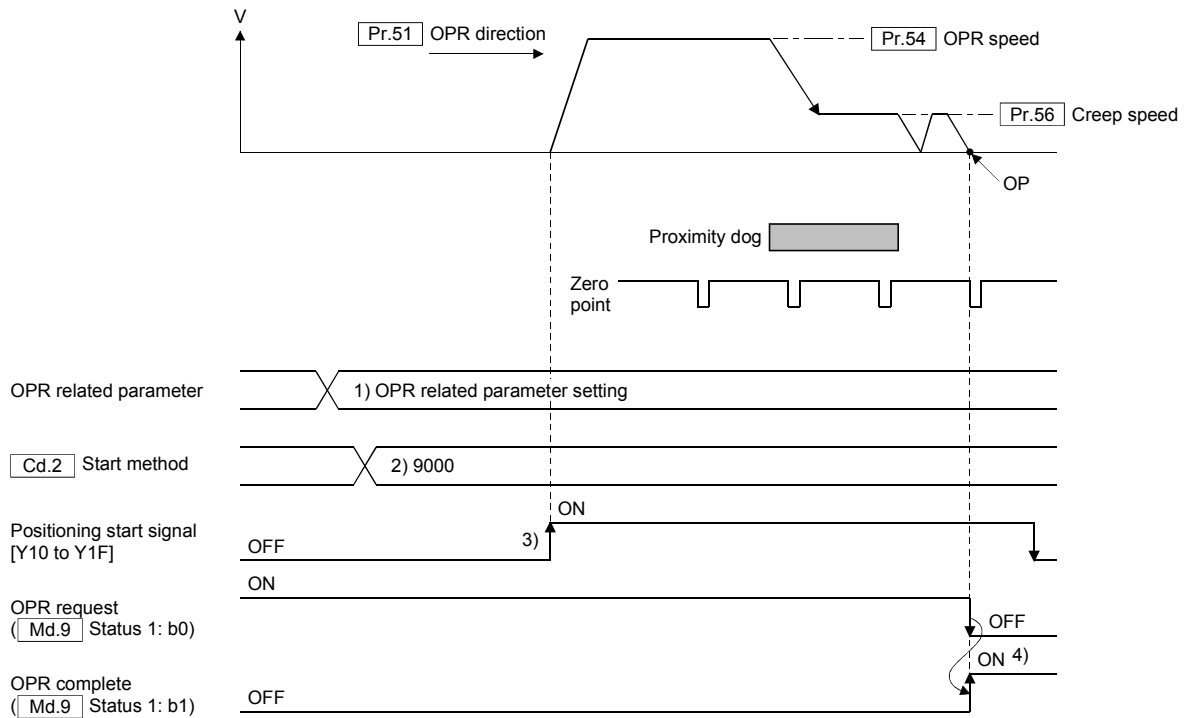

7.2 Proximity Dog Type

A method where deceleration begins when the proximity dog turns ON and then the OP is defined as the first zero point after the proximity dog turns back OFF.

Operation outline is shown below.

(1) There is a proximity dog in the direction of OPR

1) Start the OPR.

(It starts to accelerate at the time set in "[Pr.58] OPR acceleration time" to the direction set in "[Pr.51] OPR direction", and it moves at the speed set in "[Pr.54] OPR speed".)

2) The proximity dog ON is detected, and it starts to decelerate at the speed set in "[Pr.56] Creep speed".

3) It decelerates to the creep speed, and subsequently moves at the creep speed.

4) It stops with the proximity dog OFF. Thereafter, it restarts and the OPR completes at the first zero point.

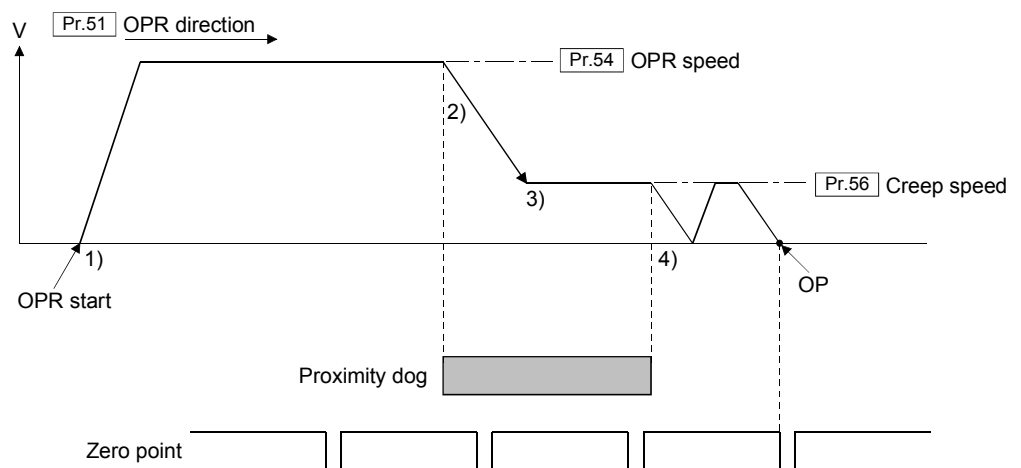

- (2) There is a proximity dog in the opposite direction against of OPR
- 1) Start the OPR.
(It starts to accelerate at the time set in "[Pr.58] OPR acceleration time" to the direction set in "[Pr.51] OPR direction", and it moves at the speed set in "[Pr.54] OPR speed".)
 - 2) It stops at the time set in "[Pr.17] Sudden stop deceleration time" with the limit switch detection of "OPR direction".
 - 3) After stop, it moves in the opposite direction against of OPR at the OPR speed.
 - 4) If the zero point is passed with the proximity dog OFF, a deceleration stop is made. (If the zero point is not passed, it continues to move until the zero point is passed, and then a deceleration stop is made.)
 - 5) After deceleration stop, it moves in the direction of OPR at the OPR speed.
 - 6) The proximity dog ON is detected, and it starts to decelerate at the speed set in "[Pr.56] Creep speed".
 - 7) It decelerates to the creep speed, and subsequently moves at the creep speed.
 - 8) It stops with the proximity dog OFF. Thereafter, it restarts and the OPR completes at the first zero point.

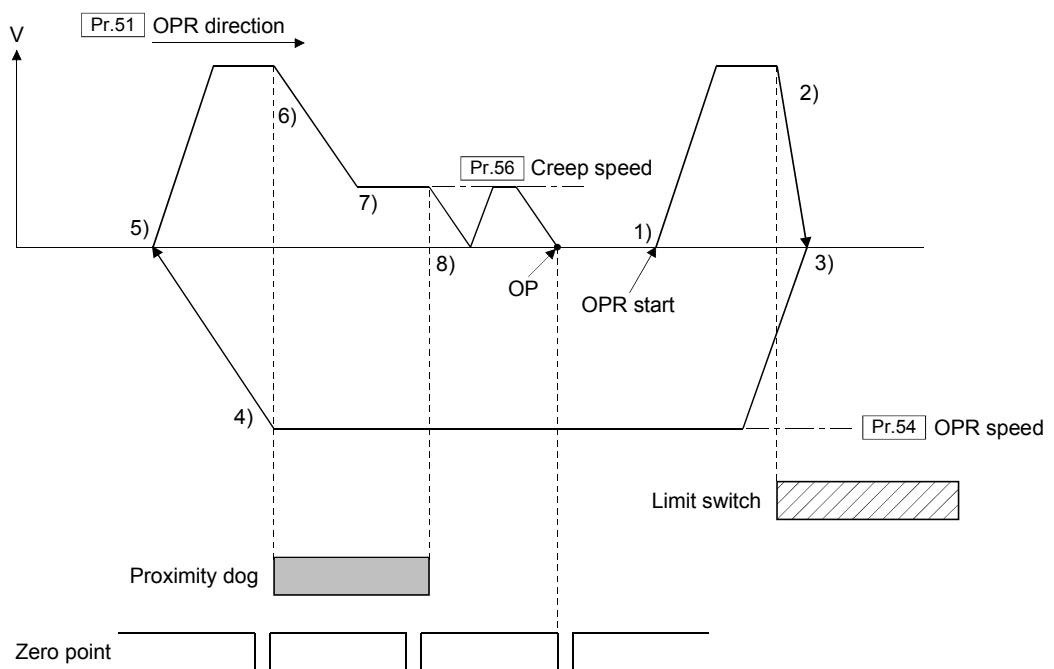
**POINT**

When the limit switch of OPR direction is detected again without the proximity dog ON after operation in (5) the above, the retry (continuation from operation in (2)) is executed again.

(3) The start position is on a proximity dog

- 1) It moves in the opposite direction against of direction set in "[Pr.51] OPR direction" at the speed set in "[Pr.54] OPR speed".
- 2) If the zero point is passed with the proximity dog OFF, a deceleration stop is made. (If the zero point is not passed, it continues to move until the zero point is passed, and then a deceleration stop is made.)
- 3) After deceleration stop, it moves in the direction of OPR at the OPR speed.
- 4) The proximity dog ON is detected, and it starts to decelerate at the speed set in "[Pr.56] Creep speed".
- 5) It decelerates to the creep speed, and subsequently moves at the creep speed.
- 6) It stops with the proximity dog OFF. Thereafter, it restarts and the OPR completes at the first zero point.

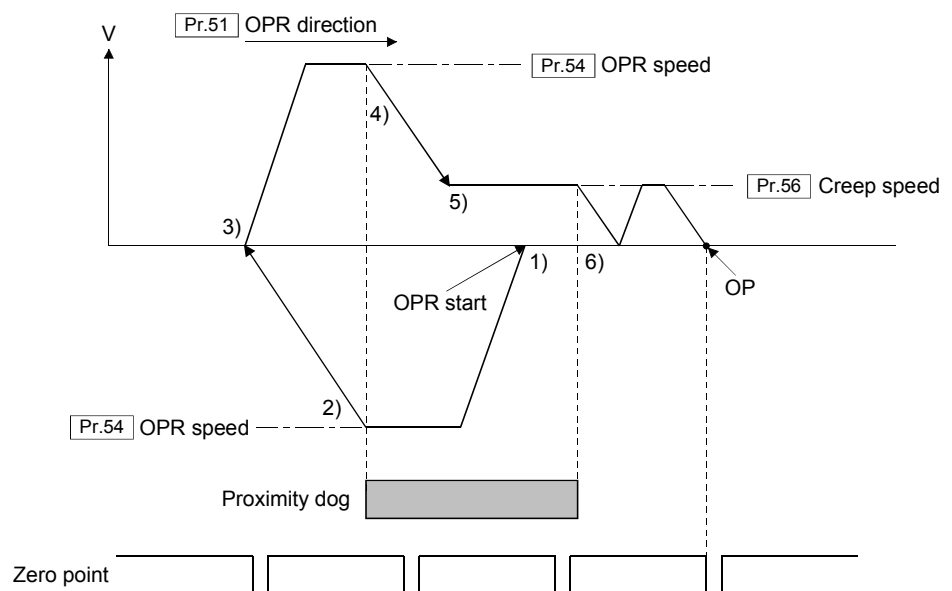
**(4) A limit switch is detected at the start up position**

If a limit switch in the direction of OPR is ON, the OPR is executed in operation of this section (2). If the limit switch in the opposite direction against of OPR is ON, the OPR is executed in operation of this section (1).

7.3 Data Set Type

A method which uses the JOG operation to move to any arbitrary position and then sets that position as the home position. A proximity dog is unnecessary. OP is the commanded position at the OPR operation.

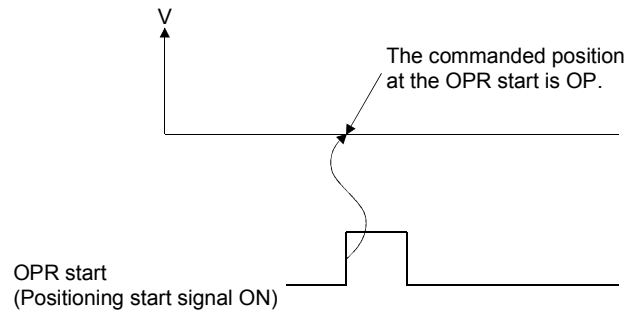

POINT

When the hardware stroke limit is detected at the OPR start, an "error code 1500" will occur, and the OPR is not completed.

7.4 Stopper Type

To set the OP, first set the torque limit to a value in which the stopper will not be damaged. Next, perform a JOG operation and continue to JOG until the torque limit is reached due to the stopper. The stopper type OPR is now set.

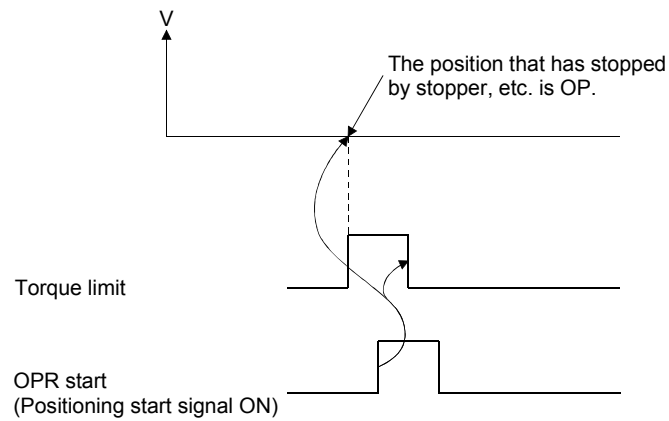

POINT

When the "Torque limit ([Md.40](#) Servo status 1: b13)" is not ON at the OPR start, an "error code 1095" will occur, and the OPR is not completed.

7.5 Dog Cradle Type

The dog cradle method performs a deceleration when the proximity dog turns ON. Then, movement direction is reversed until the dog turns back OFF. At this point, movement is again towards the dog sensor but at the set creep speed. As soon as the dog turns back ON again, movement stops and the OP is defined. Operation outline is shown below.

(1) There is a proximity dog in the direction of OPR

- 1) Start the OPR.
(It starts to accelerate at the time set in "[Pr.58] OPR acceleration time" in the direction set in "[Pr.51] OPR direction", and it moves at the speed set in "[Pr.54] OPR speed".)
- 2) The proximity dog ON is detected, and a deceleration stop is made.
- 3) After deceleration stop, it moves in the opposite direction against of OPR at the OPR speed.
- 4) If the zero point is passed with the proximity dog OFF, a deceleration stop is made. (If the zero point is not passed, it continues to move until the zero point is passed, and then a deceleration stop is made.)
- 5) After deceleration stop, it moves in the direction of OPR at the speed set in "[Pr.56] Creep speed", and the OPR completes at the first zero point after proximity dog ON.

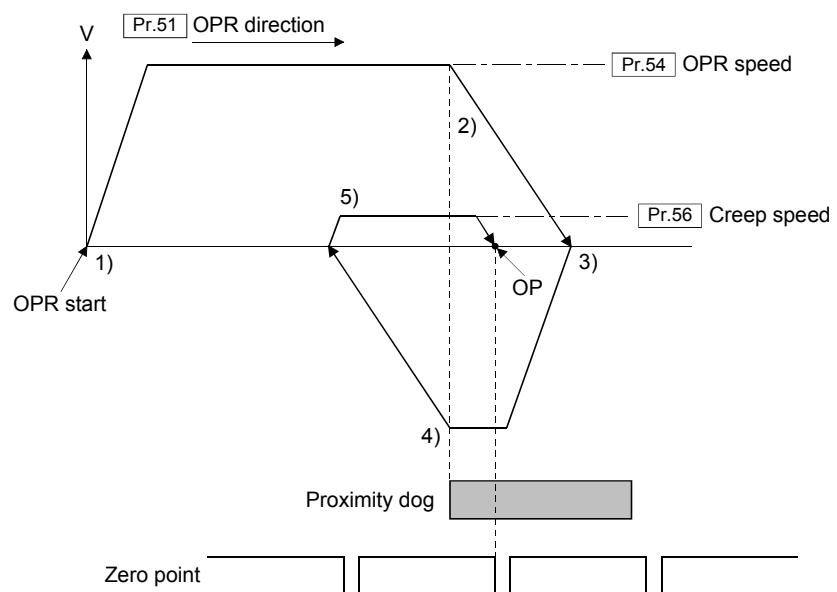

- (2) There is a proximity dog in the opposite direction against of OPR
- 1) Start the OPR.
(It starts to accelerate at the time set in "[Pr.58] OPR acceleration time" to the direction set in "[Pr.51] OPR direction", and it moves at the speed set in "[Pr.54] OPR speed".)
 - 2) It stops at the time set in "[Pr.17] Sudden stop deceleration time" with the limit switch detection of "OPR direction".
 - 3) After stop, it moves in the opposite direction against of OPR at the OPR speed.
 - 4) If the zero point is passed with the proximity dog OFF, a deceleration stop is made. (If the zero point is not passed, it continues to move until the zero point is passed, and then a deceleration stop is made.)
 - 5) After deceleration stop, it moves in the direction of OPR at the speed set in "[Pr.56] Creep speed", and the OPR completes at the first zero point after proximity dog ON.

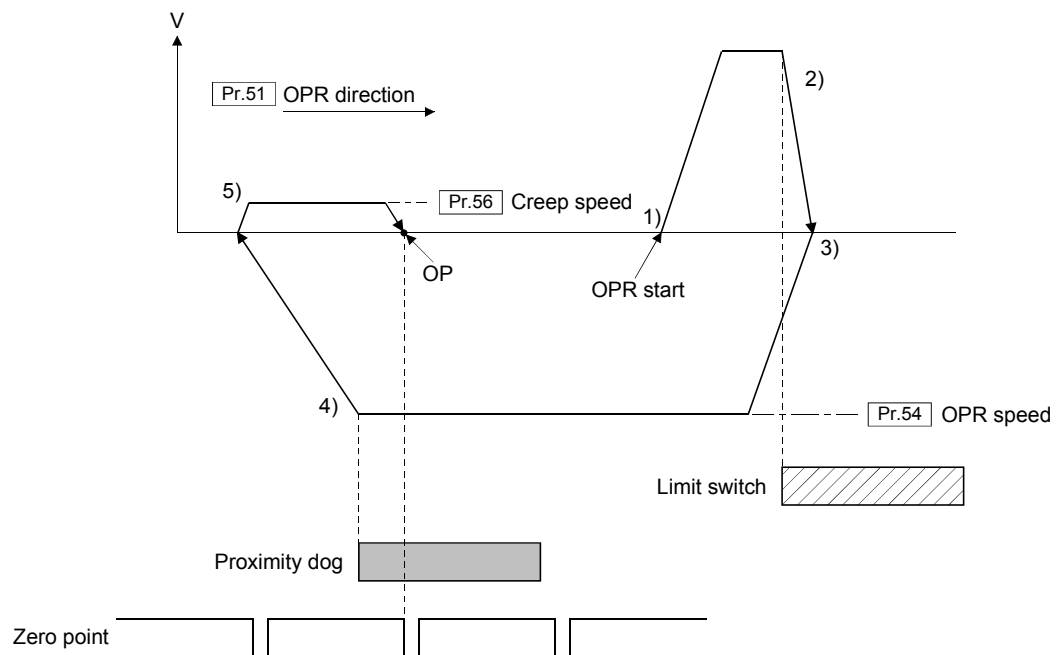

(3) The start position is on a proximity dog

- 1) It moves in the opposite direction against of direction set in "[Pr.51] OPR direction" at the speed set in "[Pr.54] OPR speed".
- 2) If the zero point is passed with the proximity dog OFF, a deceleration stop is made. (If the zero point is not passed, it continues to move until the zero point is passed, and then a deceleration stop is made.)
- 3) After deceleration stop, it moves in the direction of OPR at the speed set in "[Pr.56] Creep speed", and the OPR completes at the first zero point after proximity dog ON.

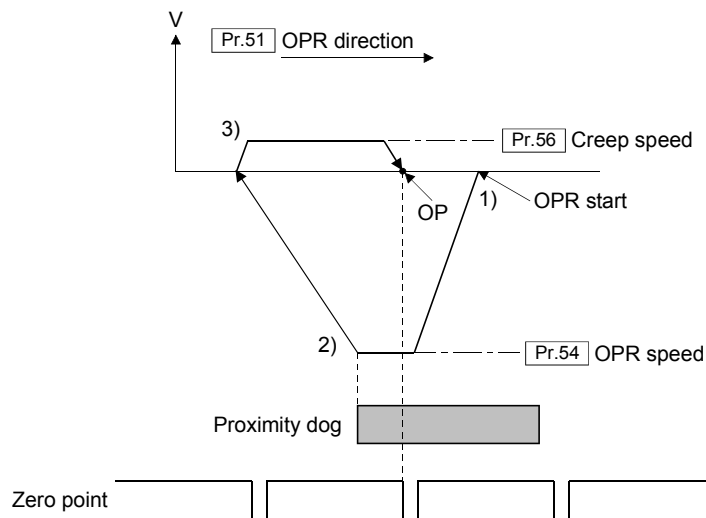

(4) A limit switch is detected at the start up position

If a limit switch in the direction of OPR is ON, the OPR is executed in operation of this section (2). If the limit switch in the opposite direction against of OPR is ON, the OPR is executed in operation of this section (1).

7.6 Limit Switch Combined Type

The limit switch sensor in the opposite direction of the home sensor is used for OPR. This method moves towards the limit switch and begins decelerating when the sensor turns on. Movement then reverses and the home position is the first Z pulse after the sensor turns back off.

Operation outline is shown below.

- 1) It moves in the opposite direction against of direction set in "[Pr.51] OPR direction" at the speed set in "[Pr.54] OPR speed".
- 2) A deceleration stop is made with the limit switch detection of the opposite direction against of OPR.
- 3) After deceleration stop, it moves in direction of OPR at the speed set in "[Pr.56] Creep speed", and it stops at the limit switch detection. Thereafter, it restarts and the OPR completes at the first zero point.

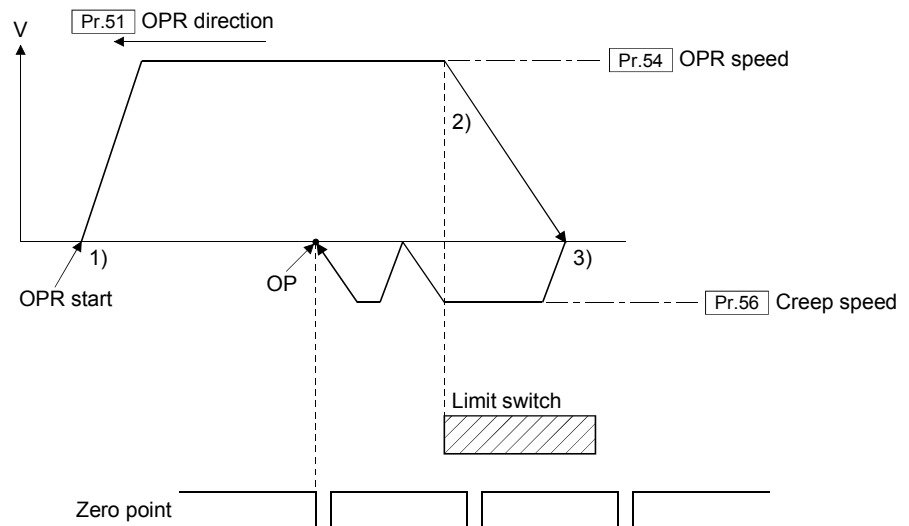
**POINT**

While it is moving in the direction of OPR at the speed set in "[Pr.56] Creep speed", the OPR is executed by calculating the movement distance to OP even if the zero point is not passed at the limit switch OFF. However, it cannot be stopped to zero point securely in the incremental encoder.

- (1) A limit switch is detected at the start up position
If a limit switch of the opposite direction against of OPR is ON at the start, the OPR is executed in operation of this section 3).

7.7 Scale Origin Signal Detection Type

The OPR is executed using a home position signal (zero point) on a linear scale. The scale origin signal detection method beings deceleration upon the dog sensor ON. Then, movement is reversed and the system detects for the linear scale's OP signal. Once detected, the system decelerates to a stop and then returns to the scale's OP at the set creep speed. For linear scales that have multiple home position signals, the position of the home position signal that is nearest the proximity dog becomes the home position. Operation outline is shown below.

⚠ CAUTION

- Set "Need to pass motor Z phase after the power supply is switched on" in "[Pr.397] Function selection C-4" when using the OPR for scale origin signal detection type. An "error code 1100" will occur at the start of the OPR for scale origin signal detection type, if "Not need to pass motor Z phase after the power supply is switched on" is set.

(1) There is a proximity dog in the direction of OPR

1) Start the OPR.

(It starts to accelerate at the time set in "[Pr.58] OPR acceleration time" in the direction set in "[Pr.51] OPR direction", and it moves at the speed set in "[Pr.54] OPR speed".)

2) The proximity dog ON is detected, and a deceleration stop is made.

3) After deceleration stop, it moves in the opposite direction against of OPR at the OPR speed.

4) After proximity dog ON, a home position signal (zero point) on a linear scale is detected, and a deceleration stop is made.

5) After deceleration stop, it moves in direction of OPR at the speed set in "[Pr.56] Creep speed", and the OPR completes at the position of home position signal (zero point).

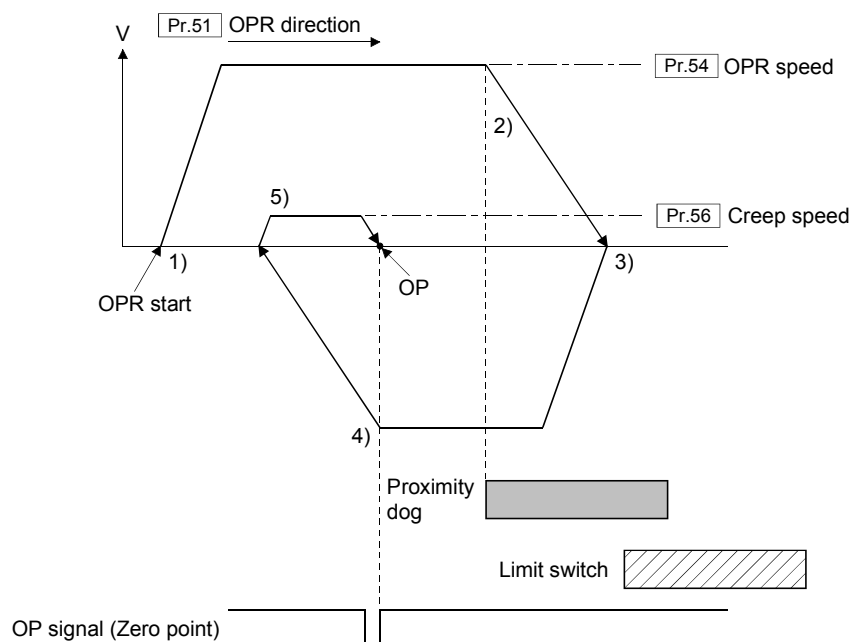

POINT
<p>(1) When a limit switch is detected, an "error code 1500" will occur and the OPR is terminated. (Retry is not executed.) When there is a proximity dog in the opposite direction against of OPR, an "error code 1500" will surely occur. Therefore, position the proximity dog in front of the limit switch signal, and as shown in the diagram, position the proximity dog signal so that it overlaps the limit switch signal.</p> <p>(2) While it is moving in the opposite direction against of OPR, it cannot be stopped until the home position search limit or the limit switch of opposite is detected.</p>

(3) The start position is on a proximity dog

- 1) It moves in the opposite direction against of direction set in "[Pr.51] OPR direction" at the speed set in "[Pr.54] OPR speed".
- 2) After proximity dog ON, a home position signal (zero point) on a linear scale is detected, and a deceleration stop is made.
- 3) After deceleration stop, it moves in direction of OPR at the speed set in "[Pr.56] Creep speed", and the OPR completes at the position of home position signal (zero point).

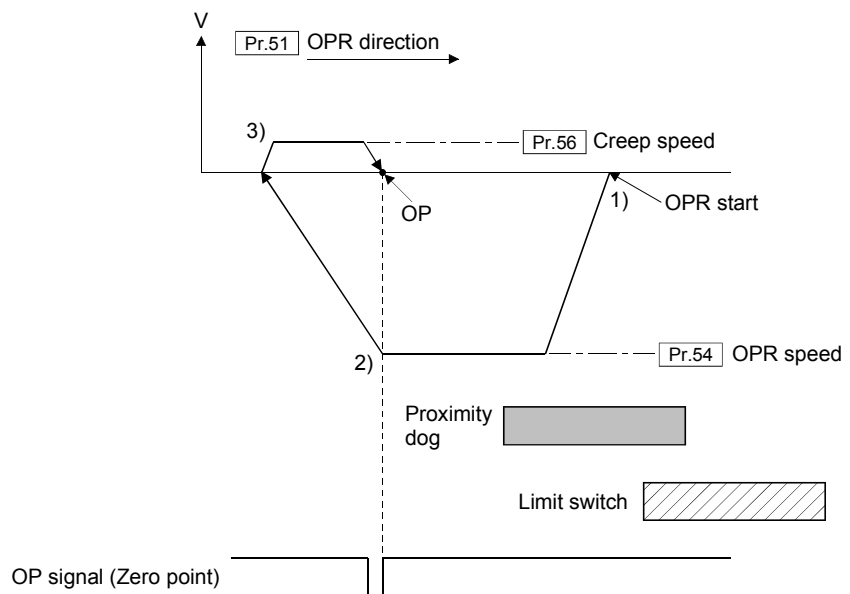

7.8 OP Shift Function

When the OPR is executed, a home position is set by using the proximity dog or zero point signal. However, by using the OP shift function, the position to which only the specified movement amount was moved from the position which detected the zero point signal can be regarded as home position.

The OPR methods corresponding to the OP shift function are shown below.

OPR Method	OP shift function
Proximity dog type	○
Data set type	×
Stopper type	×
Dog cradle type	○
Limit switch combined type	○
Scale origin signal detection type	○

○: Possible ×: Not possible

7.8.1 Control details

Operation for the OP shift function is shown below.

(1) OP shift amount is positive value

When a positive value is set in "[Pr.60] OP shift amount", it moves in the direction set in "[Pr.51] OPR direction".

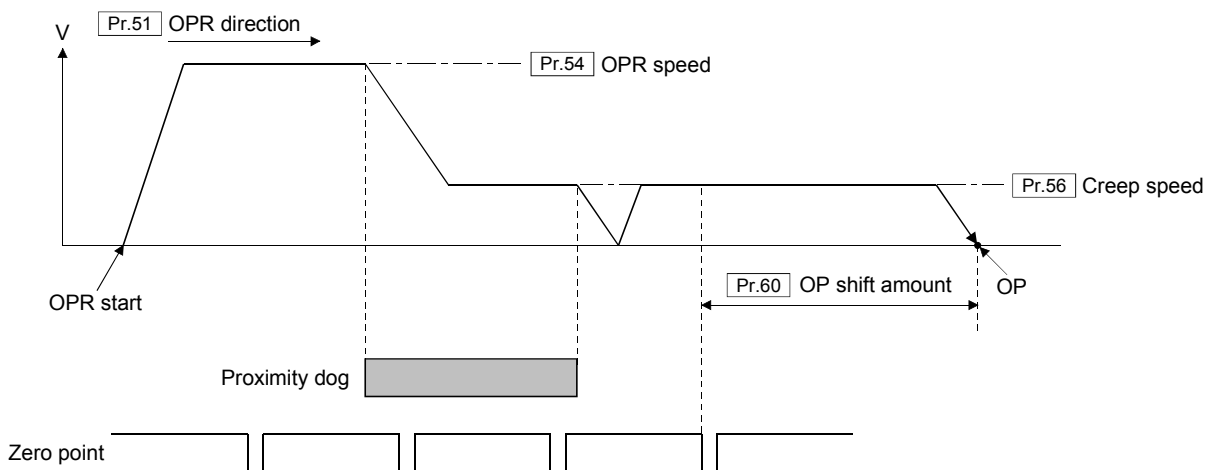

(1) OP shift amount is negative value

When a negative value is set in "Pr.60 OP shift amount", it moves in the opposite direction against of direction set in "Pr.51 OPR direction".

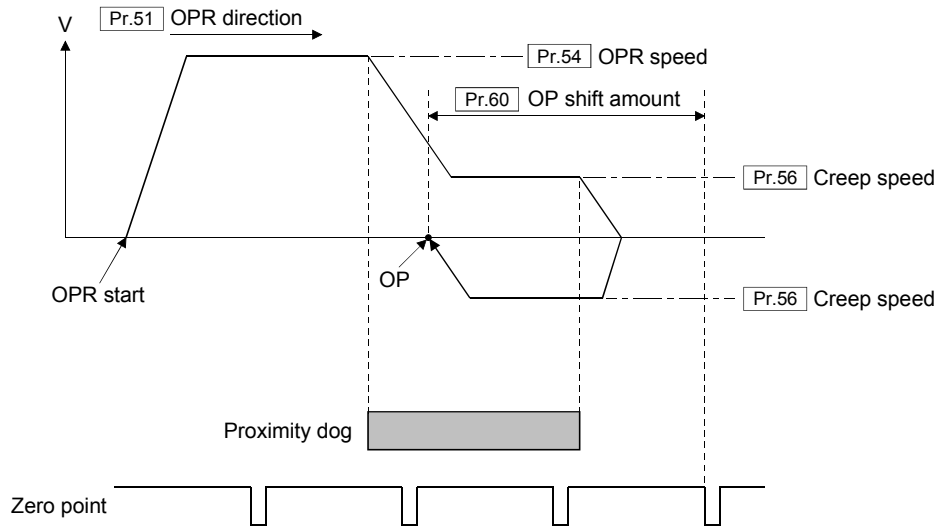

7.8.2 Setting range of OP shift amount

Set "Pr.60 OP shift amount" within the range of from the detected zero point signal to upper/lower limit switches. If the outside the range is set, an "error code 1500" will occur and the OPR is not completed.

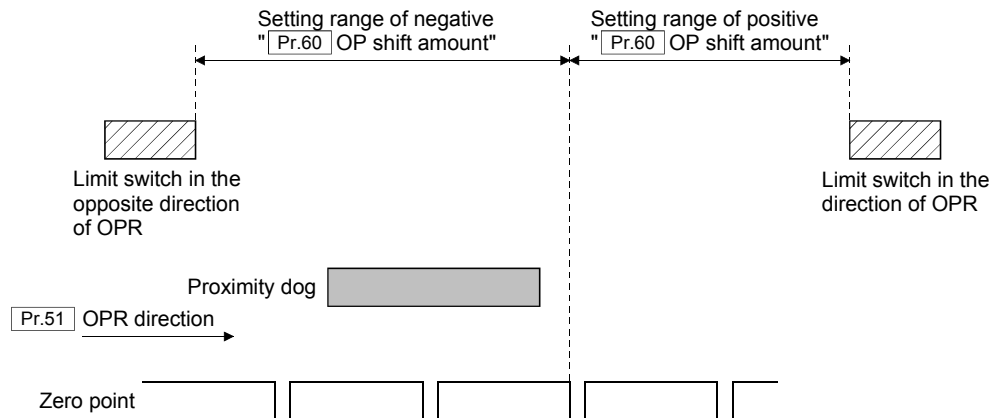

7.9 OP Search Limit Function

This function is that through movement operation in the opposite direction of OPR (movement operation in the direction of OPR for the limit switch combined type), if the movement exceeds the parameter set in "[Pr.62] OP search limit", an "error code 1098" will occur and the OPR is terminated. (It stops by setting of sudden stop time.) This function is used to prevent over run in case the proximity dog signal and limit switch cannot detect correctly due to a failure.

The OPR methods corresponding to the OP search limit function are shown below.

Method	OP search limit function
Proximity dog type	○
Data set type	×
Stopper type	×
Dog cradle type	○
Limit switch combined type	○
Scale origin signal detection type	○

○: Possible ×: Not possible

7.9.1 Control details

Operation for the OP search limit function is shown below.

- (1) OPR for dog cradle type (ex. The proximity dog OFF cannot be detected.)

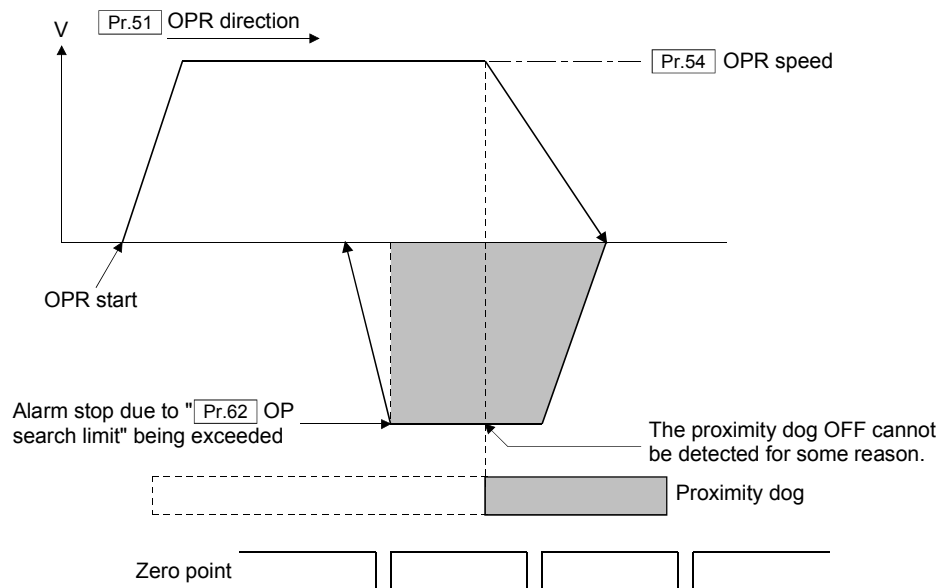

(2) OPR for limit switch combined type (ex. The limit switch OFF cannot be detected.)

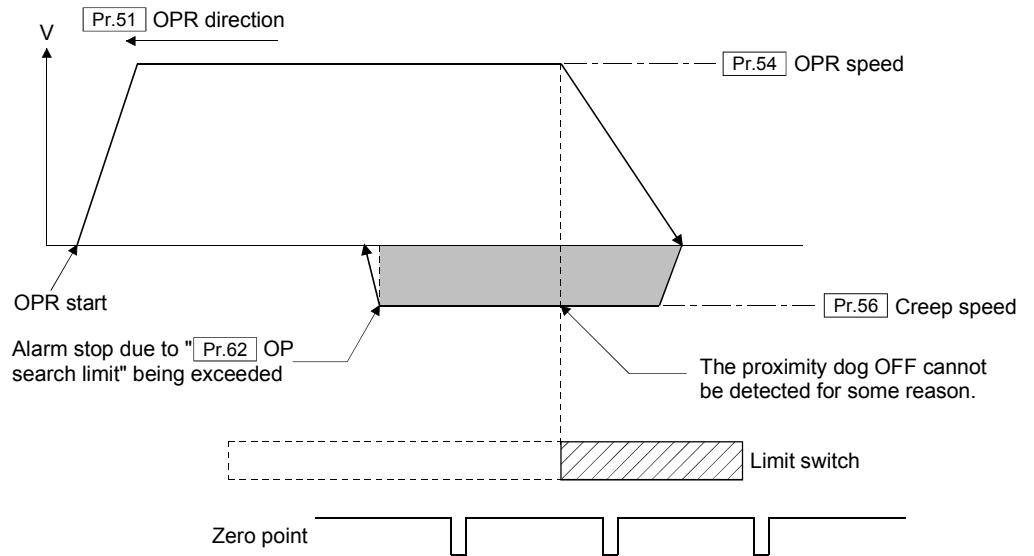

MEMO

8. POSITIONING CONTROL

8.1 Outline of Positioning Controls

Positioning controls can be executed using the positioning data stored in QD74MH. It can be executed by starting the positioning data that set the required items, Set the control system in "[Da.1] Control system" of the positioning data. Positioning control list is shown below.

Positioning control			Control system	Details
Linear control	1-axis linear control		ABS linear 1 INC linear 1	Positioning of a designated 1 axis can be executed from the start address (current stop position) to the designated position.
	Interpolation control	2 to 4-axes linear interpolation control	ABS linear interpolation INC linear interpolation	Using the designated 2 to 4 axes which group is set by parameter, linear interpolation control can be executed out from the start address (current stop position) to the designated position. POINT Up to 4 groups can be set as a group for combination of interpolation axis.

8.1.1 Data required for positioning control

Positioning data used for positioning controls are shown below. The positioning data of 32 points can be set for each axis. Refer to Section 6.3 to 6.8 for the buffer memory address and details.

	Symbol	Items	Details
Positioning data	Da.0	Operation pattern	Set the operation pattern of continuous positioning data.
	Da.1	Control system	Set the control system of positioning.
	Da.2	Acceleration time	Set the acceleration time to accelerate for positioning.
	Da.3	Deceleration time	Set the deceleration time to decelerate for positioning.
	Da.4	Command speed	Set the speed of positioning.
	Da.6	Positioning address/movement amount	Set the positioning address/movement amount of positioning.
	Da.8	Dwell time	Set the time from the completion of positioning data until the judgment of the QD74MH positioning completion.

8.1.2 Operation patterns of positioning controls

"[Da.0] Operation pattern" can be set to designate whether to continue executing positioning data after the started positioning data.

The following 3 types can be set in "[Da.0] Operation pattern".

- Independent positioning (Operation pattern: 0)
- Continuous positioning (Operation pattern: 1)
- Continuous path (Operation pattern: 3)

Examples of operation patterns in which "1-axis linear control (ABS linear 1)" is set in positioning data No.1 to No.6 of axis 1 is shown below.

Positioning data No.1	Positioning to address [A] at command speed [a]	Operation pattern = 3: Continuous path	-----No.1 Start-----  -----Positioning----- complete
No.2	Positioning to address [B] at command speed [b]	Operation pattern = 3: Continuous path	
No.3	Positioning to address [C] at command speed [a]	Operation pattern = 1: Continuous positioning	
No.4	Positioning to address [D] at command speed [b]	Operation pattern = 1: Continuous positioning	
No.5	Positioning to address [E] at command speed [a]	Operation pattern = 0: Independent positioning	
No.6	Positioning to address [F] at command speed [b]	Operation pattern = 3: Continuous path	

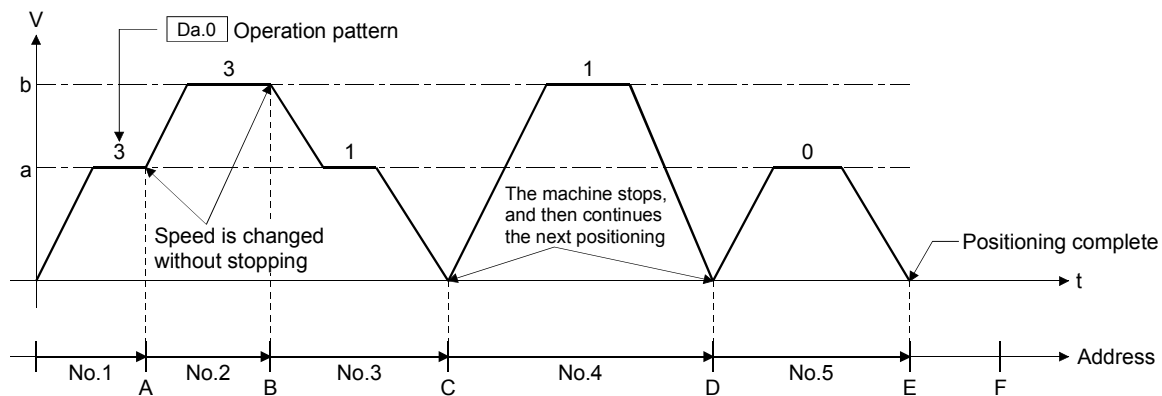

(Note): It is possible to start from an arbitrary point by setting the point.

(1) Independent positioning

One positioning data can be executed in this control. If a dwell time is set, the positioning will complete after the specified time elapses.

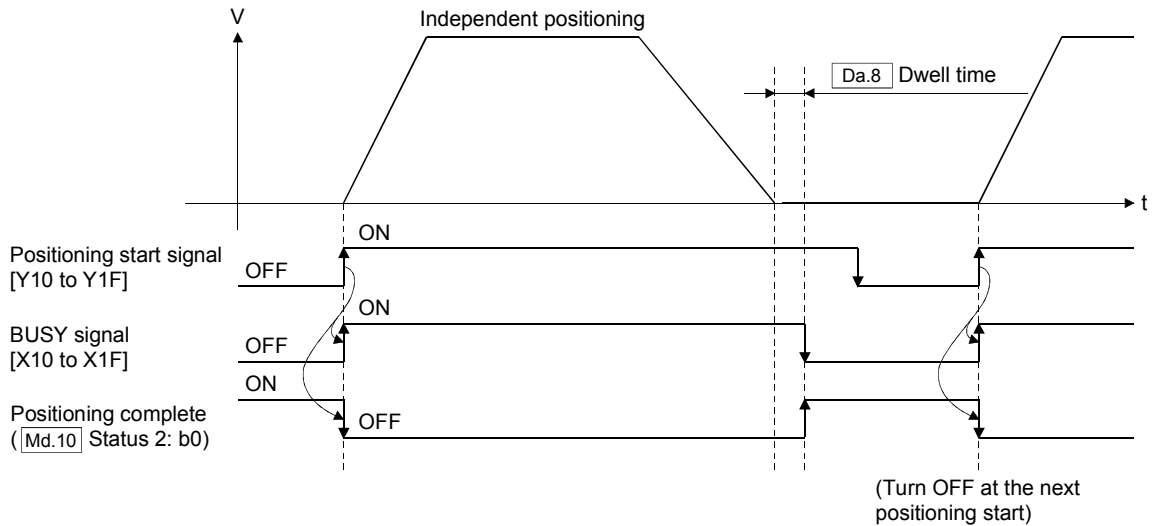

(2) Continuous positioning

It always automatically decelerates each time the positioning is completed. Acceleration to operate the next positioning data is executed after the command speed reaches "0".

If a dwell time is set, acceleration to operate the next positioning data after the specified time elapses.

In operation by continuous positioning, the next positioning is automatically executed. Always set the independent positioning in the last positioning data to complete the positioning.

If the independent positioning is not set, an "error code 1022" will occur at the switching to the 32nd point, and the positioning cannot be started.

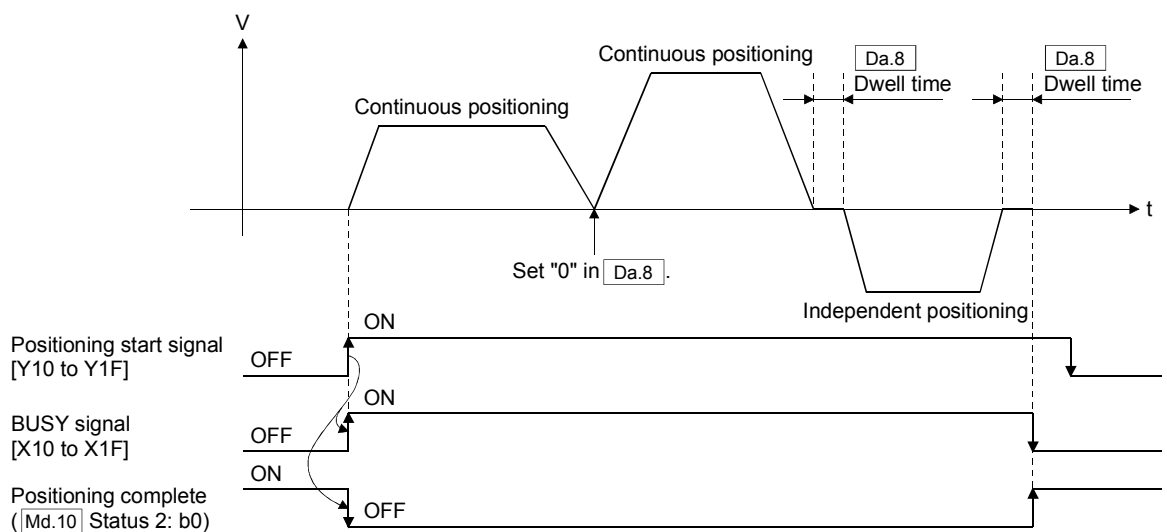

(3) Continuous path

The speed can be changed without deceleration stop between the command speed of the positioning data currently being run and the speed of the positioning data that will be run next. The speed switching of next positioning data is executed after passing the point.

If a dwell time is set, a deceleration stop is made and it starts to move to the next point after the specified time elapses.

In operation by continuous path, the next positioning is automatically executed. Always set the independent positioning in the last positioning data to complete the positioning.

If the independent positioning is not set, an "error code 1022" will occur at the switching to the 32nd point, and a deceleration stop is made.

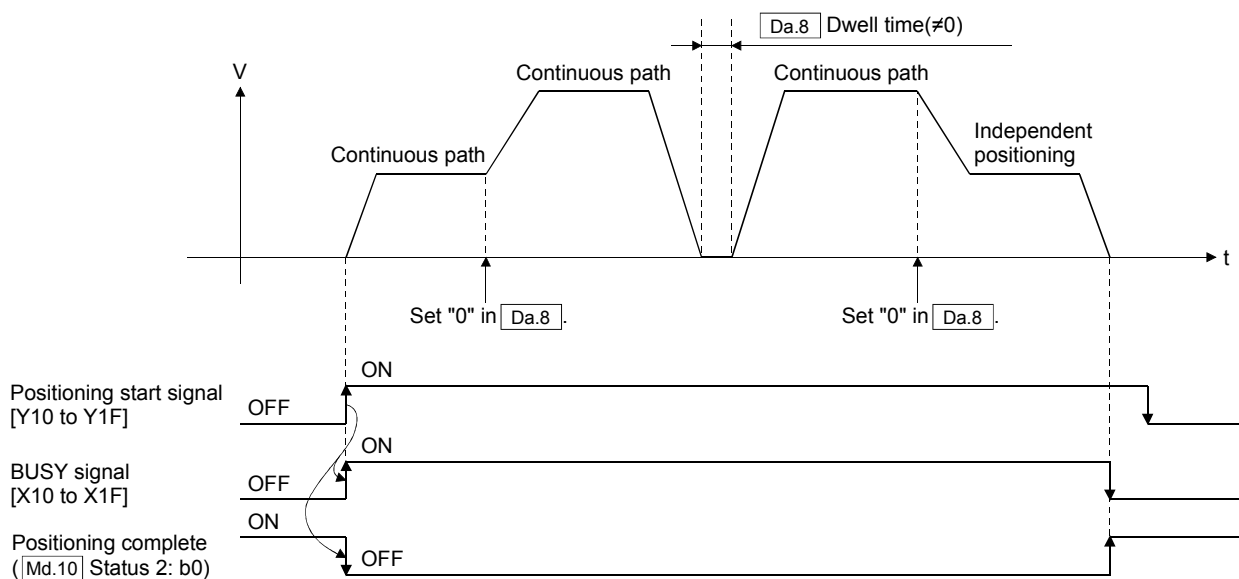

POINT
(1) Do not reverse a movement direction in the "positioning data" of continuous path for 1-axis linear control. If a direction is reversed, an "error code 1024" will occur and a deceleration stop is made. (A movement direction can be reversed in the continuous path at the interpolation control.)
(2) Set an address or movement amount where continuous stop is possible in the positioning data of continuous path end. If the movement amount is small, a "warning code 11005" or "warning code 11006" will occur, and the operation is stopped suddenly.
(3) The point data is input at the timing of point switching for the continuous path.

8.1.3 Designating the positioning address

There are two methods (absolute system and incremental system) to design a position in the positioning control. Each method can be set in "[Da.1] Control system".

(1) Absolute system

Positioning can be executed by specifying a position (absolute address) based on the home position.

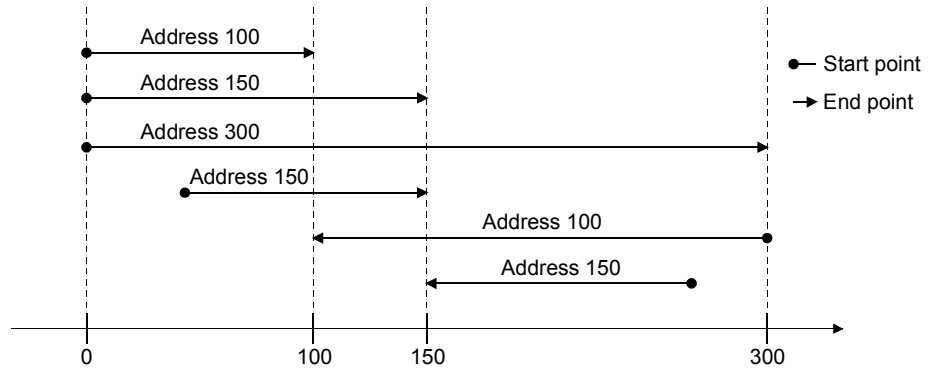

(2) Incremental system

Positioning can be executed by specifying a movement direction and movement amount based on the position that has currently stopped.

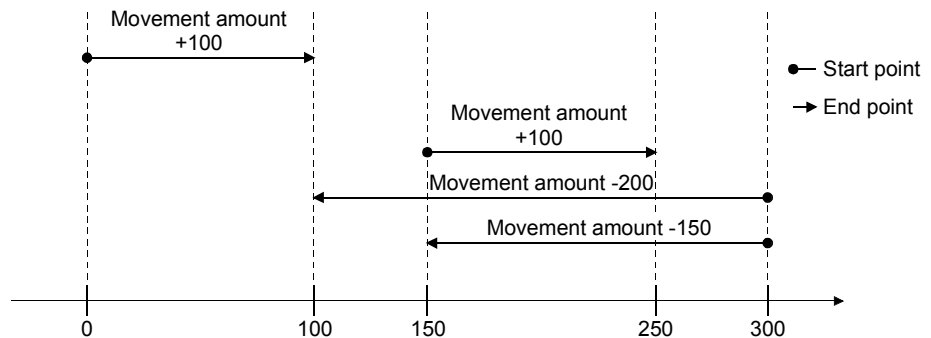

8.2 1-axis Linear Control

This control is used to execute the position control for 1 axis.

[Da.1] Control system	0: ABS linear 1
	1: INC linear 1

8.2.1 Starting method

The starting method for 1-axis linear control is shown below.

- 1) Set the items of positioning data.
- 2) Set the starting positioning data No. in "[Cd.2] Start method".
- 3) Turn the positioning start signal [Y10 to Y1F] ON.
- 4) The BUSY signal [X10 to X1F] is turns OFF by the positioning completion, and the "Positioning complete ([Md.10] Status 2: b0)" is turns ON.

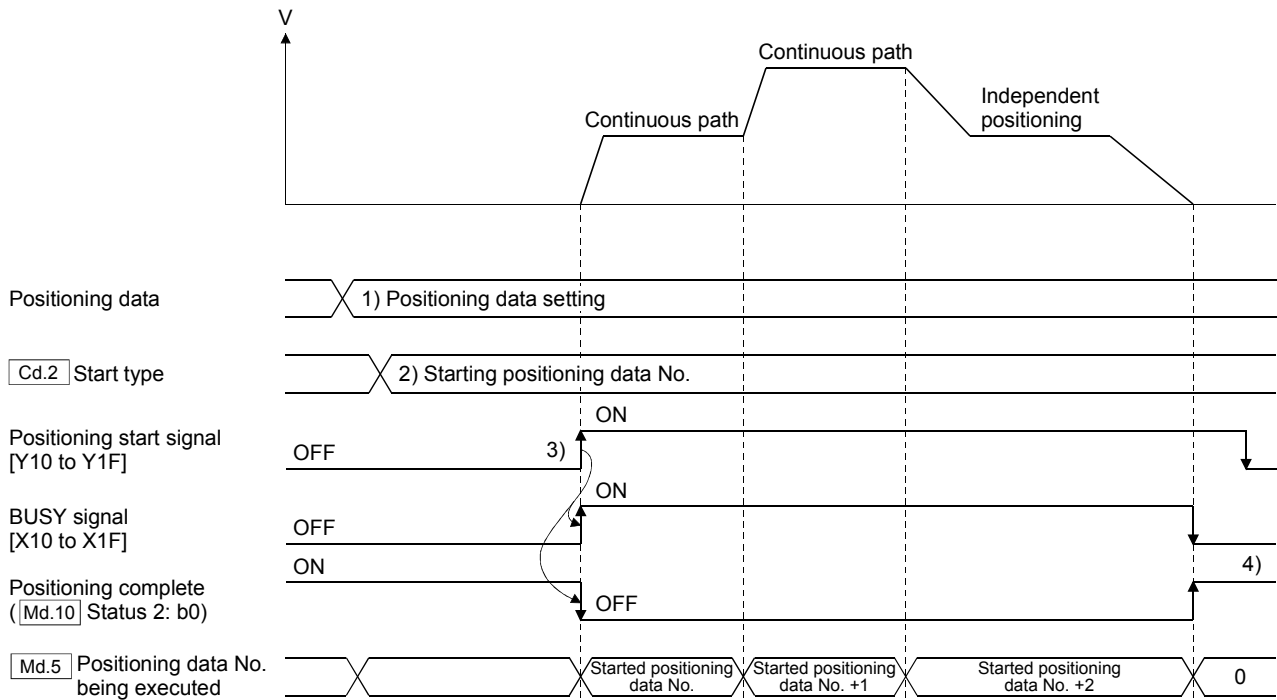

8.2.2 Control details

(1) ABS linear 1

In absolute system 1-axis linear control, positioning is executed from the start point address (current stop position) to the end point address (address set in "[Da.6] Positioning address/movement amount") by using addresses established by OPR.

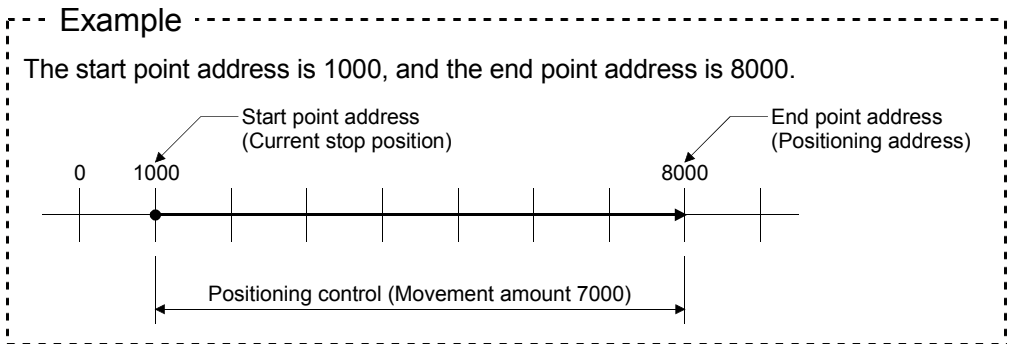

(2) INC linear 1

In incremental system 1-axis linear control, positioning is executed from the start point address (current stop position) to a position at the end of the movement amount set in "[Da.6] Positioning address/movement amount" by using addresses established by OPR are used. The movement direction is depended by a sign of movement amount.

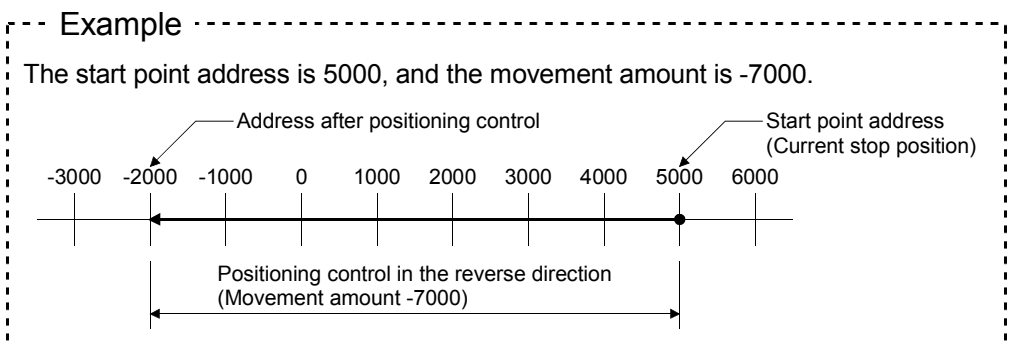
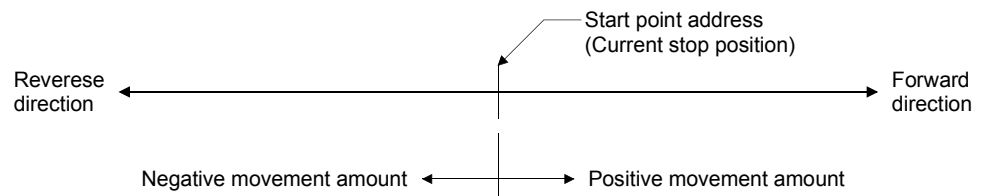

8.2.3 Restrictions for 1-axis linear control

- (1) When the "continuous positioning" or "continuous path" is set in "[Da.0] Operation pattern", and the "ABS linear 1" or "INC linear 1" is set in "[Da.1] Control system", if the except "1-axis linear control" is set to the next positioning data, an "error code 1023" will occur at the point shift, and the positioning is completed. (The point shift from "ABS linear 1" to "INC linear 1", or from "INC linear 1" to "ABS linear 1" are possible.)

In an "error code 1023" occurs at the point shift of continuous path, the operation will stop immediately.

- (2) If the following setting value is set that it decelerates at once after it reaches the command speed by acceleration and is set, it does not reach the command speed, and the constant speed section is caused.

- "[Da.2] Acceleration time"
- "[Da.3] Deceleration time"
- "[Da.4] Command speed"
- "[Da.6] Positioning address/movement amount"

If it does not reach the command speed because the setting value of "positioning address/movement amount" is small, it becomes operation similar to the above.

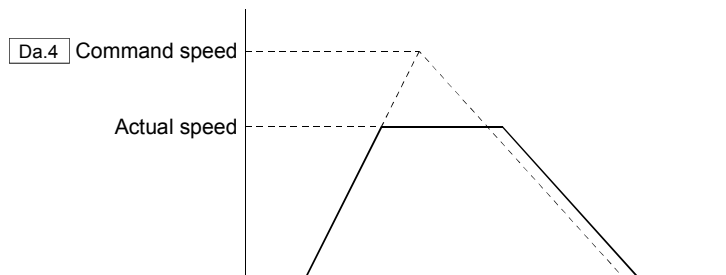

If the setting value of "[Da.2] Acceleration time" is short, the constant speed section might become long.

8.3 Linear Interpolation Control

This control is used to execute the position control in a linear path while executing interpolation for the axis directions set in each axis for the axes set as a group.

Up to 4 axes interpolation controls are possible in QD74MH.

The linear interpolation control for all axes set in one group can be executed by setting the positioning address and command speed in the positioning data, and by input the positioning start signal.

Da.1	Control system	2: ABS linear interpolation 3: INC linear interpolation
------	----------------	--

Afterwards, the axis in which the positioning start signal is input is defined as the "reference axis", and the other axis is defined as "interpolation axis".

8.3.1 Data used for control

There are data that set to both of "reference axis" and "interpolation axis", and data that set to only "reference axis".

The parameters, control data and positioning data used for the linear interpolation control are shown below.

Refer to Section 6.3 to 6.8 for the buffer memory address and details.

	Symbol	Items	Details	Reference axis	Interpolation axis	
Parameter	Pr.10	Speed limit value	Set the maximum speed for each axis.	○	○	
	Pr.25	Interpolation group	Set the group to specify the combination for axes to be interpolation-controlled.	○	○	
	Pr.26	Linear interpolation speed limit value	Set the maximum speed at the linear interpolation control.	○	—	
Control data	Cd.2	Start method	Set the starting positioning data No. Set to only "reference axis". The positioning data of the same No. as the "interpolation axis" are used to the "interpolation axis".	○	—	
Positioning data	Da.0	Same positioning No.	Operation pattern	Set the operation pattern for the continuous positioning data.	○	—
	Da.1		Control system	Set the positioning control system.	○	—
	Da.2		Acceleration time	Set the acceleration time.	○	—
	Da.3		Deceleration time	Set the deceleration time.	○	—
	Da.4		Command speed	Set the positioning speed.	○	—
	Da.6		Positioning address/movement amount	Set the positioning address/movement amount.	○	○
	Da.8		Dwell time	Set the time from when the positioning data ends to when the positioning completes.	○	—

○: Must be set —: Must be not set

8.3.2 Setting of linear interpolation axis

Always set the basic parameter "[Pr.25] Interpolation group" to execute the linear interpolation. The interpolated axis can be set to "interpolation group". Set the same value to "interpolation group" of interpolated axes. Up to 4 axes can be set to one group, and up to 4 groups can be set.

The interpolation control can be executed for the axes that set the same value to the interpolation group. When the "ABS linear interpolation" or "INC linear interpolation" is set in "[Da.1] Control system" of reference axis, and the positioning start signal [Y10 to Y1F] is turned ON, the all axes of same interpolation group can be started to execute the interpolation control.

The data of reference axis are used in the following positioning data. (The value set in the positioning data of the interpolation axis is ignored.)

- "[Da.0] Operation pattern"
- "[Da.1] Control system"
- "[Da.2] Acceleration time"
- "[Da.3] Deceleration time"
- "[Da.4] Command speed"
- "[Da.8] Dwell time",

Set only "[Da.6] Positioning address/movement amount" for the all axes of the same group for the interpolation control.

POINT
(1) Always set the basic parameter "[Pr.25] Interpolation group" to execute the interpolation. When "0" is set to interpolation group, an "error code 1040" will occur.
(2) The interpolation group becomes valid by input from the buffer memory at the PLC READY ON.
(3) Do not turn ON the positioning start signal [Y10 to Y1F] of the interpolation axis except reference axis at the interpolation control start. An error may occur at the start.
(4) The linear interpolation can be started for the axes that set the same value to the interpolation group. A part of the axes cannot be started among those axes.
(5) A single axis can be started by setting the "ABS linear interpolation" or "INC linear interpolation" in "[Da.1] Control system" even if "Interpolation group" is set.

8.3.3 Starting method

The starting method for linear interpolation control is shown below.

- 1) Set the parameters required for linear interpolation control.
- 2) Set the items of positioning data. Set the all items for reference axis, and set only "[Da.6] Positioning address/movement amount" for interpolation axis.
- 3) Set the starting positioning data No. in "[Cd.2] Start method" of reference axis.
- 3) Turn the positioning start signal [Y10 to Y1F] ON of reference axis.
- 4) The BUSY signal [X10 to X1F] both of reference axis and interpolation axis are turn OFF by the positioning completion, and the "Positioning complete ([Md.10] Status 2: b0)" is turns ON.

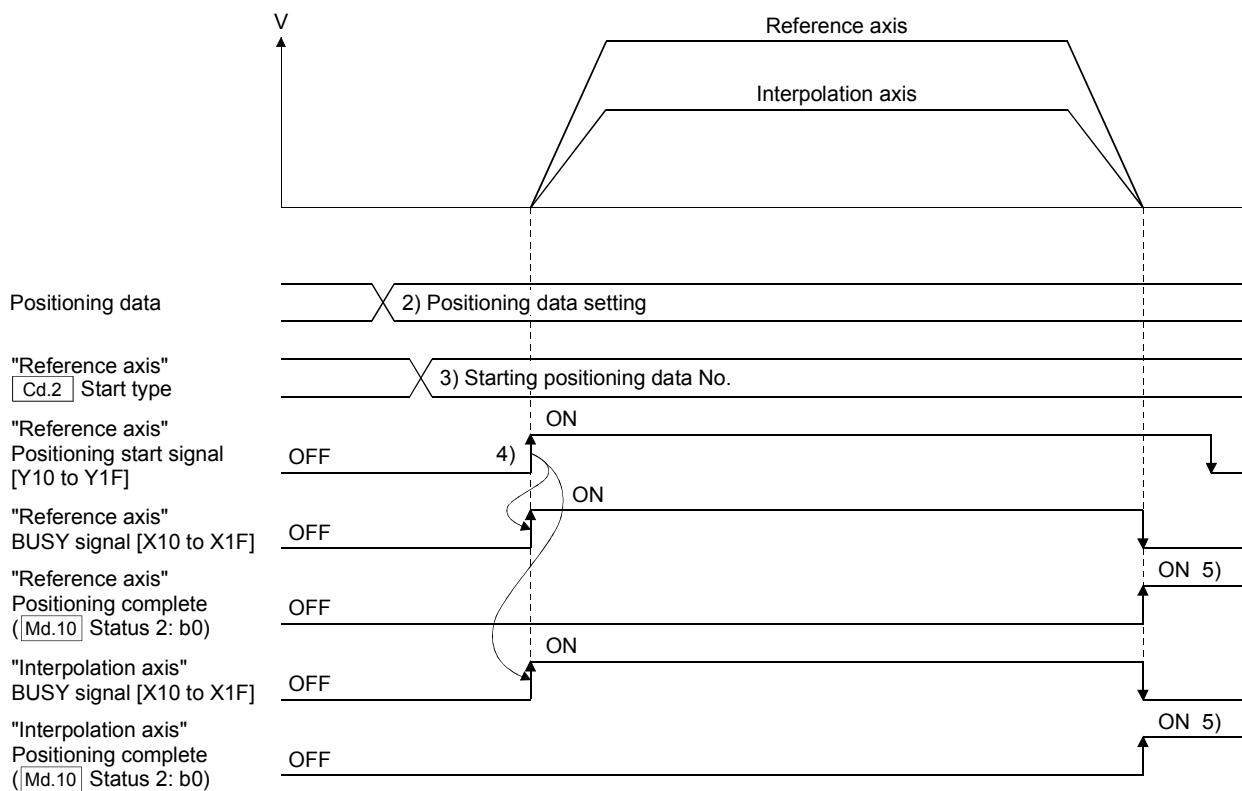

8.3.4 Control details

(1) ABS linear interpolation

In absolute system 1-axis linear control, linear interpolation positioning is executed from the start point address (current stop position) to the end point address (address set in "[Da.6] Positioning address/movement amount") by using addresses established by OPR.

• 2-axes linear interpolation control

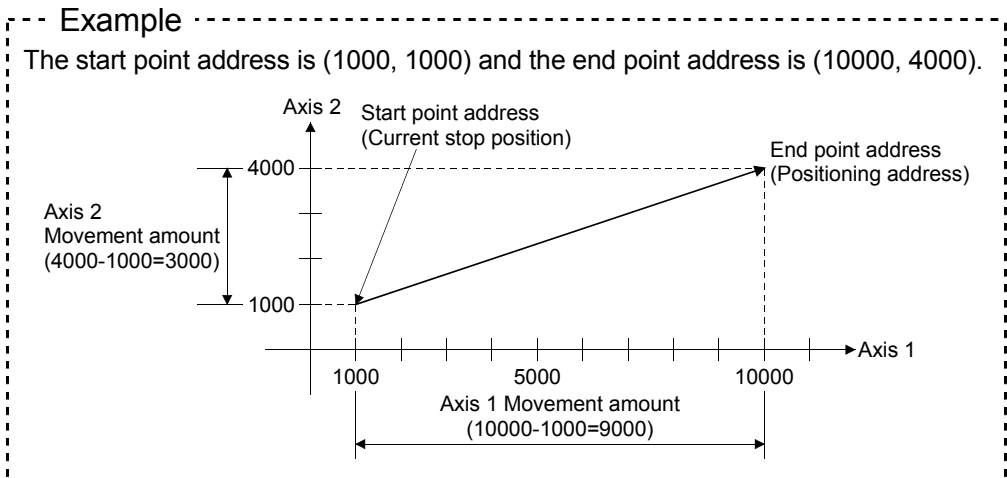
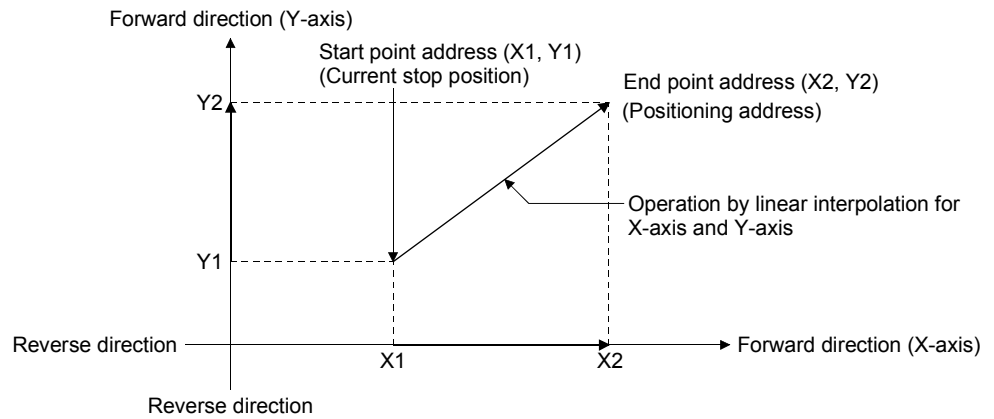

(2) INC linear

In incremental system 2-axes linear interpolation control, linear interpolation positioning is executed from the start point address (current stop position) to a position at the end of the movement amount set in "[Da.6] Positioning address/movement amount" by using addresses established by OPR are used. The movement direction is depended by a sign of movement amount.

- 2-axes linear interpolation control

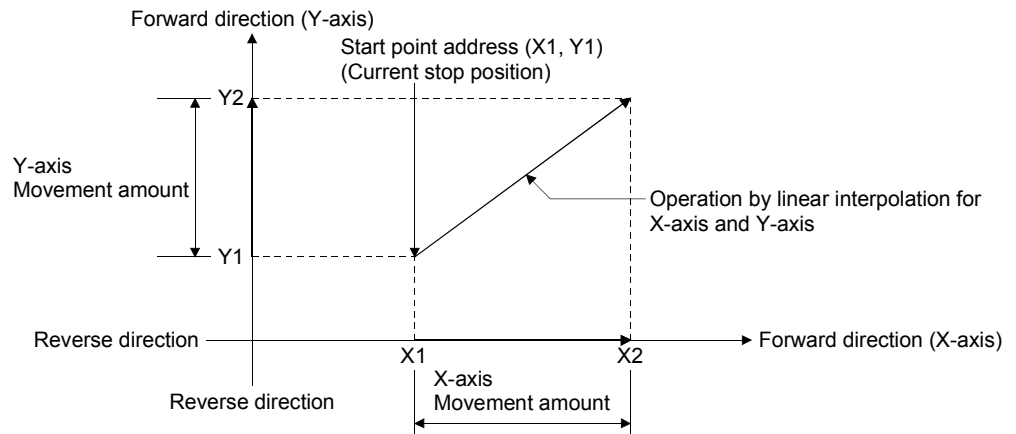

Example

The start point address is (1000, 4000), the movement amount of axis 1 is 9000 and the movement amount of axis 2 is -3000.

The example diagram shows a 2D coordinate system with 'Axis 1' on the horizontal axis and 'Axis 2' on the vertical axis. The start point is labeled 'Start point address (Current stop position)' at coordinates (1000, 4000). The end point is labeled 'Stop address after the positioning control' at coordinates (10000, 1000). The 'Axis 1 Movement amount (9000)' is shown as the horizontal distance from 1000 to 10000. The 'Axis 2 Movement amount (-3000)' is shown as the vertical distance from 4000 down to 1000. A diagonal line connects the start and end points, representing the linear interpolation path.

8.3.5 Speed/acceleration/deceleration

The speed of each axis in linear interpolation control is equal to the speed at which "[Da.4] Command speed" set in the positioning data of reference axis is distributed with the movement amount.

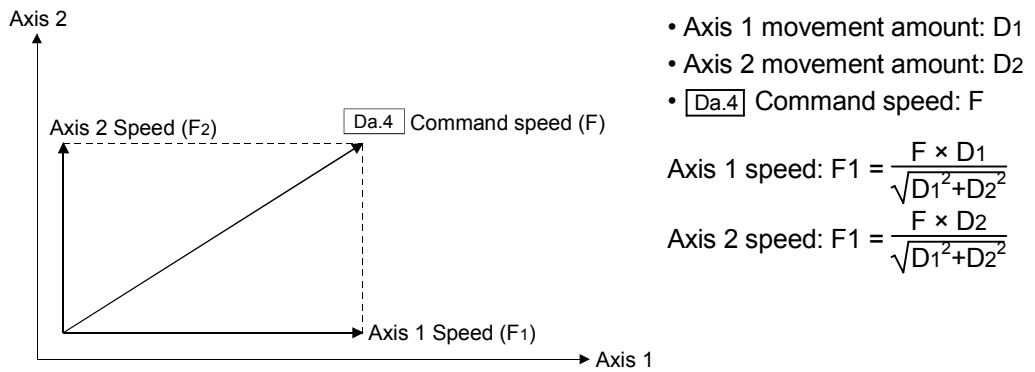

Fig. 8.1 Speed for linear interpolation control

POINT

(1) The vector speed is limited by "[Pr.26] Linear interpolation speed limit value" in the interpolation control.

(2) Also, the speed of each axis is limited by the parameter "[Pr.10] Speed limit value" of each axis. In that case, the speed for the other axes is also cramped to match the cramped axes.

Set the acceleration/deceleration time to the positioning data of reference axis in the linear interpolation control.

Set "[Da.2] Acceleration time" and "[Da.3] Deceleration time" within the range of "[Pr.26] Linear interpolation speed limit value".

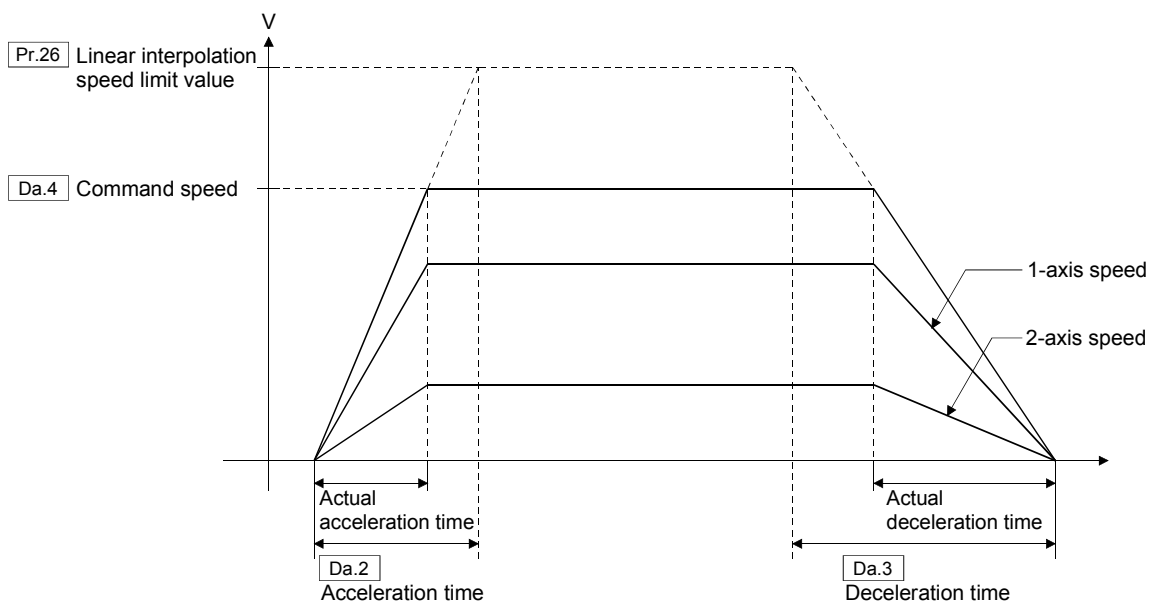

Fig. 8.2 Acceleration/deceleration time for linear interpolation control

8.3.6 Restrictions

- (1) Up to 4 groups can be set in "[Pr.25] Interpolation group". For 16 axes control, it cannot be used as "2 axes interpolation × 8 groups".
- (2) In the following cases, an "error code 1040" will occur in reference axis, and the linear interpolation cannot be started.
 - One group is defined with 5 or more axes.
 - The linear interpolation is started with a group number that exceeds the valid group number.
- (3) In the following cases, an "error code 1041" will occur in reference axis, and an "error code 1016" will occur in interpolation axis, and the linear interpolation cannot be started.
 - There is an axis whose amount of movement exceeds the maximum of 999999999 in one axis.
- (4) An "error code 1042" will occur in reference axis, and the linear interpolation cannot be started, if it is started while the busy signal is ON, or an alarm is set in the linear interpolation control.
- (5) A corresponding error in the axis that caused the error, and an "error code 1016" in the other axes will occur, if an error will occur in the linear interpolation control start.
- (6) An "error code 1501" in the corresponding axis and an "error code 1016" in the other axes will occur, if there is an axis that moves from within software stroke limits to outside the limits.
- (7) The command change is executed to the reference axis. Request of change to the interpolation axis becomes invalid, and the following warning codes will occur.
 - Warning code 11011 When changing speed
 - Warning code 11012 When changing acceleration time
 - Warning code 11013 When changing deceleration time
- (8) Target position change cannot be executed in the linear interpolation control. Request of target position change becomes invalid, and an "warning code 11014" will occur.
- (9) When the "continuous positioning" or "continuous path is set in "[Da.0] Operation pattern", and the "ABS linear 1" or "INC linear 1" is set in "[Da.1] Control system", if the except "linear interpolation" is set to the next positioning data, an "error code 1023" will occur at the point shift, and the deceleration stop is made. (The point shift from "ABS linear 1" to "INC linear 1", or from "INC linear 1" to "ABS linear 1" are possible.)

(10) If the following setting value is set that it decelerates at once after it reaches the command speed by acceleration and is set, it does not reach the command speed, and the constant speed section is caused.

- "Da.2 Acceleration time"
- "Da.3 Deceleration time"
- "Da.4 Command speed"
- "Da.6 Positioning address/movement amount"

If it does not reach the command speed because the setting value of "positioning address/movement amount" is small, it becomes operation similar to the above.

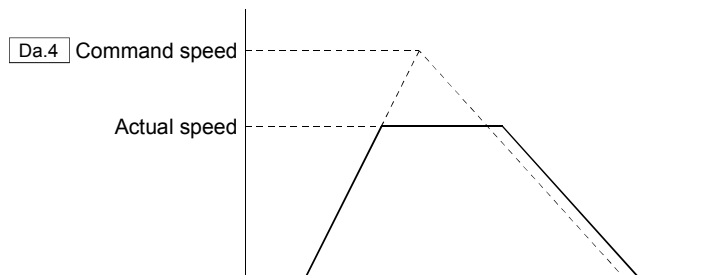

If the setting value of "Da.2 Acceleration time" is short, the constant speed section might become long.

9. MANUAL CONTROL

"Manual control" refers to control in which positioning data is not used. The two types (JOG operation, incremental feed operation) of this "manual control" are explained below.

9.1 JOG Operation

In the JOG operation, the command is output from the QD74MH to the servo amplifier while "1" is set by setting "1" in "[Cd.8] Forward rotation JOG start" or "[Cd.9] Reverse rotation JOG start", and it makes to move the work piece in the specified direction. While the positioning start signal [Y10 to Y1F] is ON, "forward rotation JOG start" and "reverse rotation JOG start" for that axis are ignored regardless of positioning executing.

CAUTION

- The feed (unlimited length feed) that exceeds the moveable range cannot be executed using the JOG operation. Doing so may cause an error with the software stroke limit, and the operation stops.

9.1.1 Control details

Operation procedure for JOG operation is shown below.

- 1) When "1" is set in "[Cd.8] Forward rotation JOG start" or "[Cd.9] Reverse rotation JOG start", an acceleration is started by the specified direction and the acceleration time set in "[Pr.82] JOG operation acceleration time". At this time, the BUSY signal [X10 to X1F] changes from OFF to ON.
- 2) When the command reaches the speed set in "[Pr.80] JOG speed", the movement continues at this speed.
- 3) When the JOG start is changed from "1" to "0", a deceleration is started by the deceleration time set in "[Pr.83] JOG operation deceleration time" from the current speed.
- 4) The operation stops when the speed becomes "0". At this time, the BUSY signal [X10 to X1F] changes from ON to OFF.

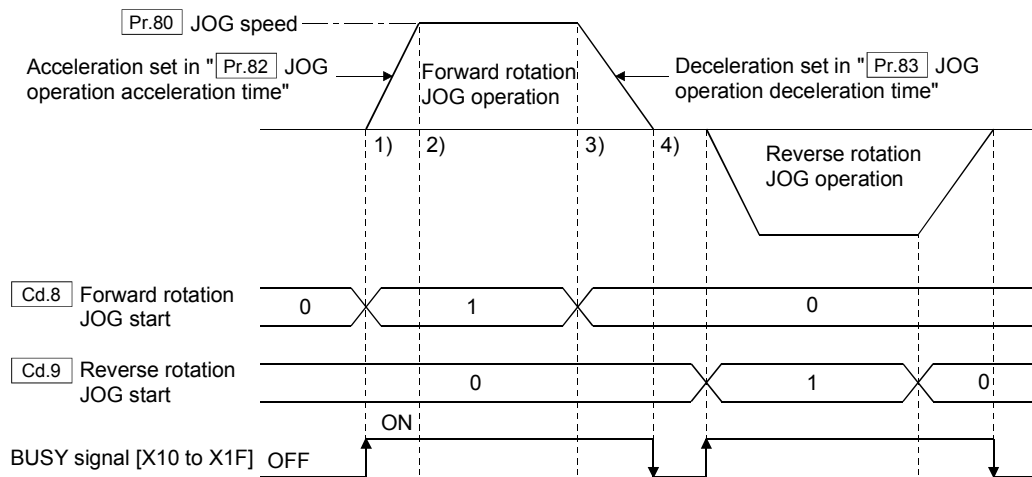

POINT
<ul style="list-style-type: none"> • JOG operation can be used without completing OPR. • Set "0" in "[Pr.84] Incremental feedrate". If except "0" is set, the incremental feed operation is executed.

(1) When "1" is set in both the forward rotation JOG start and reverse rotation JOG start simultaneously

When "1" is set in both "[Cd.8] Forward rotation JOG start" and "[Cd.9] Reverse rotation JOG start" simultaneously for one axis, the "forward rotation JOG start" is given priority. In this case, the reverse rotation JOG start signal is validated when the forward rotation JOG operation is stopped.

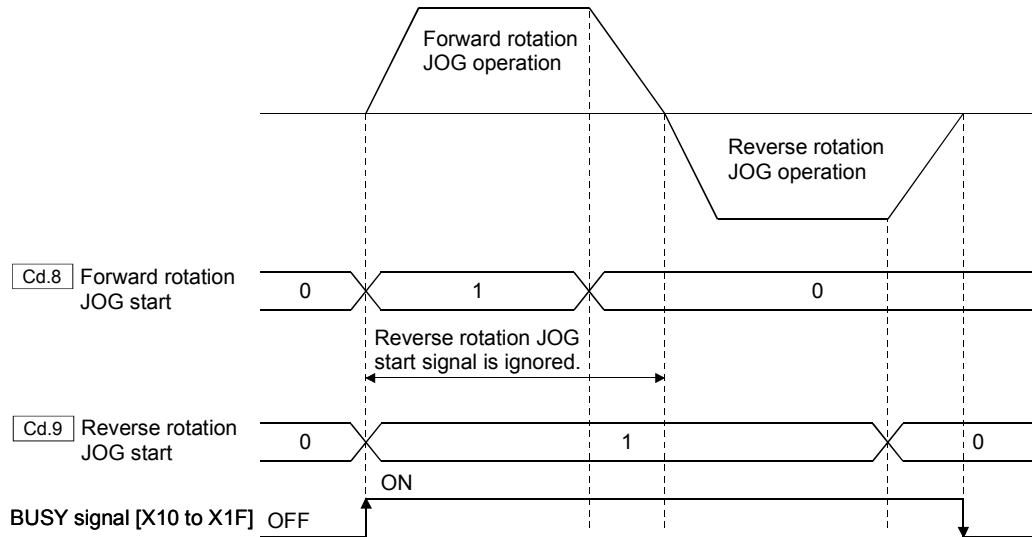

(2) When "1" is set again in JOG start during deceleration caused by changing from "1" to "0" of JOG start setting

When "1" is set again in JOG start for same direction during deceleration caused by changing from "1" to "0" of JOG start setting, the acceleration and JOG operation are executed without waiting for the stop.

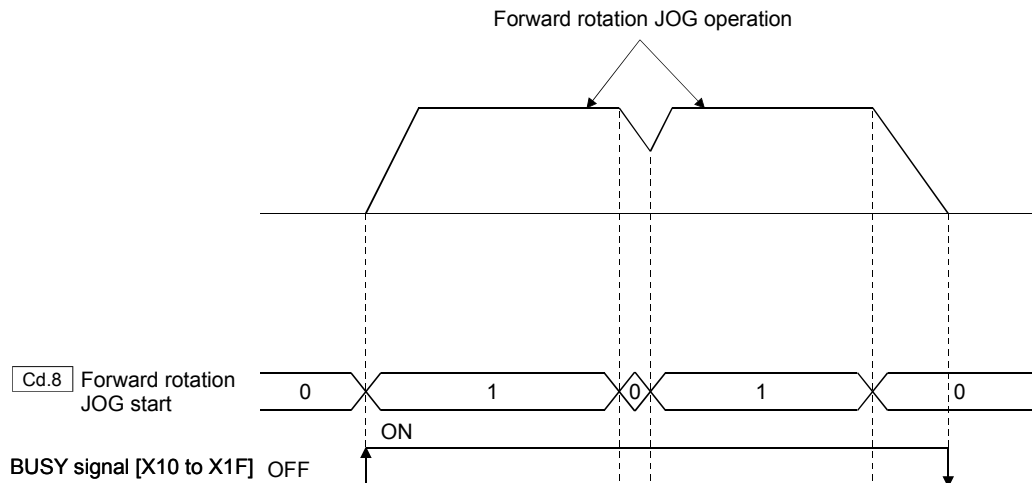

9.1.2 Data used for control

The parameters and control data used for JOG operation are shown below.
Refer to Section 6.3 to 6.8 for the buffer memory address and details.

	Symbol	Item	Details
Parameter	Pr.80	JOG speed	Set the speed for JOG operation.
	Pr.82	JOG operation acceleration time	Set the acceleration time for JOG operation.
	Pr.83	JOG operation deceleration time	Set the deceleration time for JOG operation.
Control data	Cd.8	Forward rotation JOG start	Start the forward rotation JOG.
	Cd.9	Reverse rotation JOG start	Start the reverse rotation JOG.

9.2 Incremental Feed Operation

In the incremental feed operation, the constant feedrate set in "[Pr.84] Incremental feedrate" is output to the servo amplifier by setting "1" in "[Cd.8] Forward rotation JOG start" or "[Cd.9] Reverse rotation JOG start".

While the positioning start signal [Y10 to Y1F] is ON, "forward rotation JOG start" and "reverse rotation JOG start" for that axis are ignored regardless of positioning executing.

9.2.1 Control details

Operation procedure for incremental feed operation is shown below.

- 1) When except "0" is set in "[Pr.84] Incremental feedrate", and "1" is set in "[Cd.8] Forward rotation JOG start" or "[Cd.9] Reverse rotation JOG start", an acceleration is started by the specified direction and the acceleration time set in "[Pr.82] JOG operation acceleration time". At this time, the BUSY signal [X10 to X1F] changes from OFF to ON.
- 2) When the command reaches the speed set in "[Pr.80] JOG speed", the movement continues at this speed.
- 3) A deceleration is started by the deceleration time set in "[Pr.83] JOG operation deceleration time" so that the movement amount that moved after operation start becomes the incremental feedrate.
- 4) The operation stops when the speed becomes "0". At this time, the BUSY signal [X10 to X1F] changes from ON to OFF.

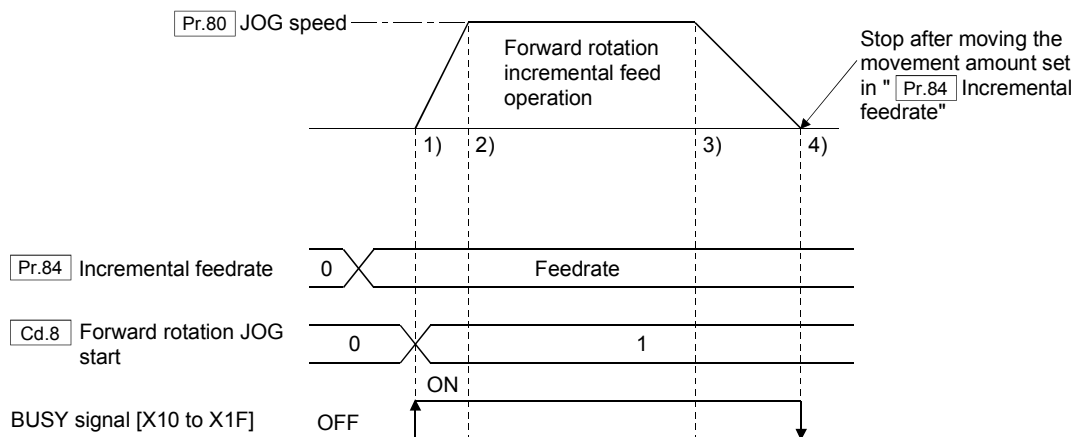

POINT

- Incremental feed operation can be used without completing OPR.
- When both the forward rotation start and reverse rotation start are set simultaneously, the "forward rotation start" is given priority. Reverse operation cannot be executed after the forward incremental feed stop.
- Set except "0" in "[Pr.84] Incremental feedrate". If "0" is set, the incremental feed operation is executed.

9.2.2 Precautions for control

If the following setting value is set that it decelerates at once after it reaches the specified JOG speed by acceleration and is set, it does not reach the specified JOG speed, and the constant speed section is caused.

- "[Pr.82] JOG operation acceleration time"
- "[Pr.83] JOG operation deceleration time"
- "[Pr.80] JOG speed"
- "[Pr.84] Incremental feedrate"

If it does not reach the specified JOG speed because the setting value of "positioning address/movement amount" is small, it becomes operation similar to the above.

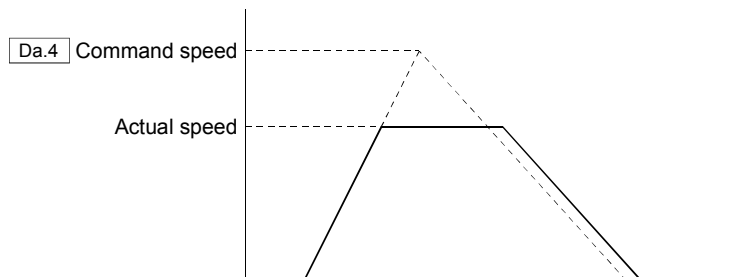

If the setting value of "[Pr.82] JOG operation acceleration time" is short, the constant speed section might become long.

9.2.3 Data used for control

The parameters and control data used for incremental feed operation are shown below.

Refer to Section 6.3 to 6.8 for the buffer memory address and details.

	Symbol	Item	Details
Parameter	Pr.84	Incremental feedrate	Set the feedrate for incremental feed.

10. FUNCTION DETAILS

10.1 Servo ON/OFF

This function is used to execute the servo ON or OFF of the servo amplifiers connected to the QD74MH.

By establishing the servo ON status with the servo ON command, servomotor operation is enabled.

10.1.1 Control details

The following two types of servo ON or OFF can be used.

- All axis servo ON signal [Y1]
- [Cd.30] Each axis servo OFF

A combination of the "All axis servo ON signal [Y1]" and "[Cd.30] Each axis servo OFF" is shown below.

		[Cd.30] Each axis servo OFF			
		Set value "0"	LED indication of servo amplifier	Set value "1"	LED indication of servo amplifier
All axis servo ON signal [Y1]	ON	○ (Note-1)	d□	× (Note-3)	c□
	OFF	× (Note-2)	b□	× (Note-2)	b□

- : Servo ON (Servo operation enabled)
- ×: Servo OFF (Servo operation disabled)

The procedure for servo ON/OFF is shown below.

- (1) Servo ON (Servo operation enabled) The above (Note-1)
 - (a) Make sure that the servo LED indicates "b□".
 - (b) Set "0" in "[Cd.30] Each axis servo OFF".
 - (c) Turn ON "All axis servo ON signal [Y1]".
(LED indication of servo amplifier : d□)

- (2) All axis servo OFF (Servo operation disabled)..... The above (Note-2)
 - (a) Turn OFF "All axis servo ON signal [Y1]".
(LED indication of servo amplifier : b□)

- (3) Each axis servo OFF (Servo operation disabled) The above (Note-3)
 - (a) Turn ON "All axis servo ON signal [Y1]".
 - (b) Set "1" in "[Cd.30] Each axis servo OFF".
(LED indication of servo amplifier : c□)
(Thereafter, the servo operation enabled if "0" is set again in "[Cd.30] Each axis servo OFF".)

POINT
<ul style="list-style-type: none"> • If the servomotor is rotated by external force during the servo OFF status, the follow up processing is executed. • An "error code 1702" will occur and the operation does not start, if the OPR control, positioning control or manual control is started in servo OFF,. • An "error code 1703" will occur and the servo OFF can be executed after sudden stop. If the servo OFF is executed in the positioning, The positioning interrupted by servo OFF cannot be resumed even if the servo OFF is executed again. • When the servo OFF is executed to all axes, "All axis servo ON signal [Y1]" is applied even if all axis servo ON command is turned ON to OFF with "<u>Cd.30</u> Each axis servo OFF" set "0".

10.1.2 Data used for control

Set the following data for the servo ON/OFF.

Refer to Section "5.1 Specifications of Input/Output Signals" and Section 6.3 to 6.8 for the buffer memory address and details.

Symbol	Items	Details
—	All axis servo ON signal [Y1]	The servo for all servo amplifiers connected to the QD74MH is turned ON or OFF.
Cd.30	Each axis servo OFF	Execute the servo ON/OFF for each axis.

10.1.3 Follow up function

If the servomotor is rotated by external force during the servo OFF status, the follow up processing is executed.

The follow up processing monitors the number of motor rotations (real current value) with the servo OFF and reflects the value in the "Current feed value".

Therefore, even if the servomotor rotates while the servo OFF, the servomotor will not just rotate for the quantify of droop pulses the next time the servo turns ON but positioning can be performed from the stop position.

POINT
<ul style="list-style-type: none"> • The follow up processing is executed if "QD74MH and the servo amplifier is turned ON" and "servo OFF" regardless of the presence of the absolute position system.

10.2 Electronic Gear Function

This function is used to adjust the position command units at positioning command to QD74MH. The machine can be moved using an arbitrary multiplication constant for the movement amount by changing the electronic gear.

10.2.1 Control details

The position in which the value of an electronic gear is multiplied by the command value to the QD74MH are output to the servo amplifier. The electronic gear is shown by the following expression.

$$\text{Electronic gear} = \frac{\text{Electronic gear numerator (AP)}}{\text{Electronic gear denominator (AL)}}$$

POINT

The setting range of the electronic gear is "1/12<AP/AL<10000".
 An "error code 1037" will occur, and the unit READY does not turn ON if the electronic gear is "1/12" or less.

(1) Setting example when the command unit is [μm] for a machine that uses ball screws

(a) Machine specifications

Ball screw lead : Pb = 10[mm] = 10000[μm]

Reduction ratio : n = 1/2

Encoder resolution : Pt = 262144[PLS/rev]

$$\frac{AP}{AL} = \frac{Pt}{\angle S} = \frac{Pt}{n \times Pb} = \frac{262144}{\frac{1}{2} \times 10000} = \frac{262144}{5000} = \frac{32768}{625}$$

(Note): ∠S is the movement amount for 1 revolution of the servomotor.

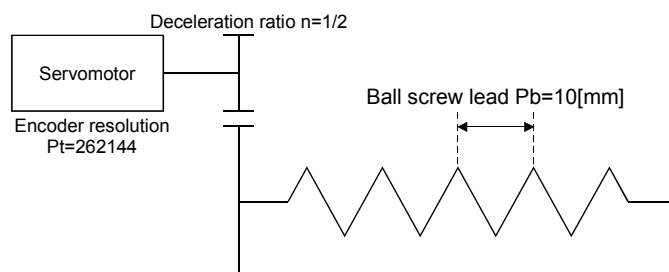

(2) Setting example when the gear's value is outside the settable range

(a) Machine specification

Ball screw lead : Pb = 10[mm] = 10000[μm]

Reduction ratio : n = 1/6

Encoder resolution : Pt = 262144[PLS/rev]

$$\frac{AP}{AL} = \frac{Pt}{\Delta S} = \frac{Pt}{n \times Pb} = \frac{262144}{\frac{1}{6} \times 10000} = \frac{262144 \times 6}{10000} = \frac{1572864}{10000} = \frac{32768 \times 3}{625} = \frac{32768 \times 3}{625} = \frac{19660.8}{125} \div \frac{19660}{125}$$

When the electronic gear's value is outside the settable range or contains a decimal point, calculate the denominator and numerator according to the following procedure.

<Procedure for setting the numerator and denominator>

The calculated value after reduction must be as close as possible to the original value.

- 1) Reduce both the numerator and denominator to as small an integer as possible. In this case, the minimum integer value is found by reducing the denominator and numerator by 16.
- 2) Regarding the numerator and denominator, one must be a true integer and the other should be rounded off to an integer. Both must be a value equal to or less than 32768.

a) Calculated value without reduction

Divide using simple division and keep the remainder after the decimal point.

$$\frac{AP}{AL} = \frac{262144}{\frac{1}{6} \times 10000} = \frac{262144 \times 6}{10000} = \frac{262144 \times 6}{10000} = \frac{1572864}{10000} = \frac{32768 \times 3}{625} = 157.2864$$

b) Result of reduction when AL is chosen to be the true integer.

Reduce the denominator (AL) to an integer, and keep the remainder after the decimal point.

$$\frac{AP}{AL} = \frac{32768 \times 3}{625} = \frac{32768 \times 3}{\frac{625}{5}} = \frac{19660.8}{125} \div \frac{19660}{125} = 157.2800$$

c) Result of reduction when AP is chosen to be the true integer

Reduce the numerator (AP) to an integer, and keep the remainder after the decimal point.

$$\frac{AP}{AL} = \frac{32768 \times 3}{625} = \frac{\frac{32768 \times 3}{3}}{\frac{625}{3}} = \frac{32768}{208.333} \div \frac{32768}{208} = 157.5384$$

- d) Subtract the result of expression a) above from that of c) and b) respectively, and then compare the results as shown below.

$$| b) - a) | = | 157.2800 - 157.2864 | = 0.0064$$

$$| c) - a) | = | 157.5384 - 157.2864 | = 0.2520$$

From the above comparison, it is easy to see that the calculation result of b) is closer to the value of a).

- 3) The value of the electronic gear has setting range and integer restrictions. Therefore, round down the calculated value of the numerator (AP) from expression (2) to the nearest integer and set it as follows.

$$AP = 19660, AL = 125$$

(Note): Due to rounding down the numerator, this setting will result in a difference in value between the machine's actual position and the position calculated by the controller.

This example's calculation error.

$$\left(\frac{\frac{125}{19660}}{\frac{625}{(3 \times 32768)}} - 1 \right) \times 100 = 4.07 \times 10^{-3} [\%]$$

This means that for every 1km of movement, there is 40.7[mm] of error. The error at the home position is 0.

Also, in an absolute position system, error does not accumulate even if power is removed at the 1km mark mentioned in this example.

(3) Setting example when the command unit is [μm] for the linear servo

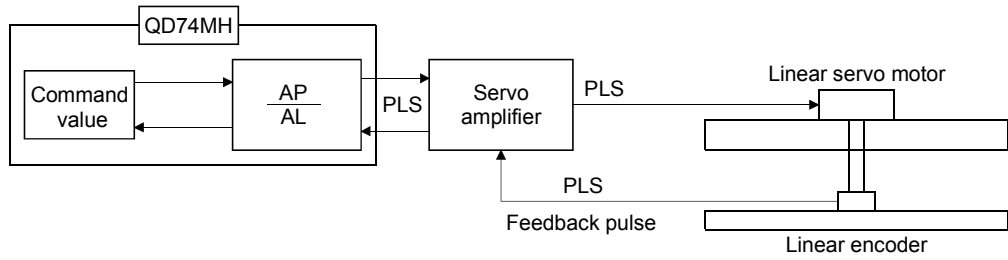

Calculate the number of pulses (AP) and movement amount (AL) for the linear encoder in the following conditions.

$$\text{Liner encoder resolution} = \frac{\text{Number of pulses(AP)}}{\text{Movement amount value(AL)}}$$

Liner encoder resolution: 0.05[μm]

$$\frac{AP}{AL} = \frac{1}{0.05} = \frac{20}{1.0} = \frac{20}{1[\times 1\mu\text{m}]} \dots\dots\dots \text{For command unit: } 1[\mu\text{m}]$$

$$= \frac{20}{10[\times 0.1\mu\text{m}]} = \frac{2}{1} \dots\dots\dots \text{For command unit: } 0.1[\mu\text{m}]$$

Set the followings.

For command unit: 1[μm]..... Pr.0 Electronic gear numerator = 20

Pr.2 Electronic gear denominator = 1

For command unit: 0.1[μm]..... Pr.0 Electronic gear numerator = 2

Pr.2 Electronic gear denominator = 1

Set the number of pulses in "Pr.0 Electronic gear numerator", and the movement amount in "Pr.2 Electronic gear denominator" in the actual setting.

10.2.2 Data used for control

Set the following parameters for the electronic gear function.

Refer to Section 6.3 to 6.8 for the buffer memory address and details.

	Symbol	Items	Details
Parameter	Pr.0	Electronic gear numerator (AP)	Set a numerator of electronic gear applied to position command.
	Pr.2	Electronic gear denominator (AL)	Set a denominator of electronic gear applied to position command.

10.3 Hardware Stroke Limit Function

CAUTION

- When the hardware stroke limit is required to be wired, ensure to wire it in the negative logic using B-contact. If it is set in positive logic using A-contact, the hardware stroke limit may not be detected even if the signal wires are disconnected.

This function is used to make stop (sudden stop) the control by the input of a signal from the limit switch, by setting the limit switches at the upper/lower limit of the physical moveable range.

Damage to the machine can be prevented by stopping the control before the upper/lower limit of the physical moveable range is reached.

Use "external input signal of servo amplifier" in the hardware stroke limit.

10.3.1 Control details

The operation for the hardware stroke limit function is shown below.

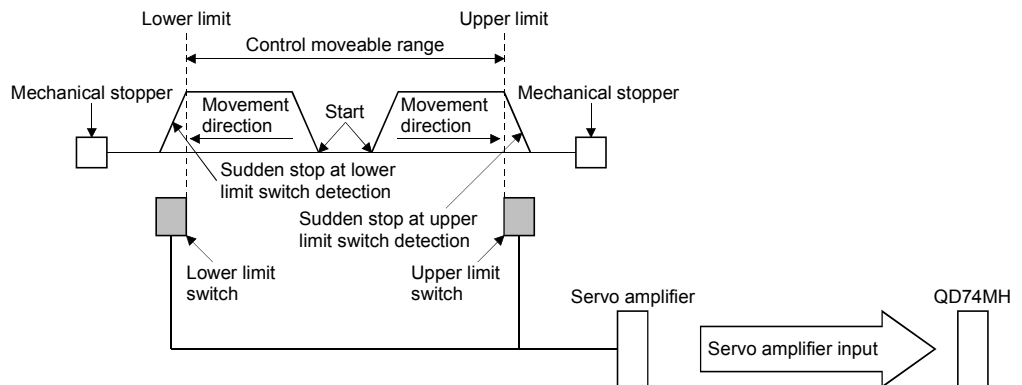

POINT

The deceleration stop is executed by setting the sudden stop deceleration time. Keep enough distance between the limit switch and the mechanical stopper in consideration of a distance necessary for the stop.

The relation between the hard ware stroke limit and the each control is shown below.

Control		At the start	In operation
Positioning control	1-axis linear control	If the limit switch of positioning direction is in operation, an "error code 1500" will occur and the operation does not start	If the limit switch of positioning direction is operated, an "error code 1500" will occur and the operation does not start
	2 to 4-axes linear interpolation control	If the limit switch of positioning direction is in operation, an "error code 1500" will occur in the axis that the stroke limit is detected, an "error code 1016" will occur in the other axes, and then the operation does not start.	If the limit switch of positioning direction is operated, an "error code 1500" will occur in the axis that the stroke limit is detected, an "error code 1016" will occur in the other axes, and then the operation does not start.
Manual control	JOG operation	If the limit switch of positioning direction is in operation, an "error code 1500" will occur and the operation does not start	If the limit switch of positioning direction is operated, an "error code 1500" will occur and the operation does not start
	Incremental feed operation		
OPR	Proximity dog type	Refer to "Section 7 OPR CONTROL".	If the limit switch of current rotation direction is operated, an "error code 1500" will occur, and the sudden stop is made. (However, an error will not occur at retry. Refer to "Section 7 OPR CONTROL".)
	Data set type	If the upper or lower limit switch is in operation, an "error code 1500" will occur and the operation does not start.	
	Stopper type		
	Dog cradle type	Refer to "Section 7 OPR CONTROL".	
	Limit switch combined type	If the limit switch of OPR direction is in operation, an "error code 1500" will occur and the operation does not start.	
Scale origin signal detection type			
Other	Current value change	Possible to change	—

POINT

- (1) If the servo is stopped with the position (prohibited area) in which the limit switch operated, it can be moved in the direction of the movement allowed area. However, execute the start operation after resetting the errors.

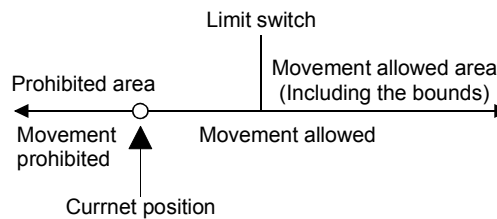

- (2) If S-curve acceleration/deceleration is set, the "[Pr.16] S-curve acceleration/ deceleration time constant" is always valid. Therefore, sudden stop as well will use the S-curve acceleration/deceleration.

10.3.2 Data used for control

Refer to Section "10.18 External Signal Logic Selection" for the input signal logic selection of limit switch.

10.4 Software Stroke Limit Function

The address established by OPR is used to set the upper and lower limits of the moveable range of the workpiece in this function.

Movement commands issued to addresses outside that setting range will not be executed.

10.4.1 Control details

The relation between the software stroke limit and the each control is shown below.

Control		Operation
Positioning control	1-axis linear control	If the positioning data of position command exceeds the software limit is started, an "error code 1501" will occur and the operation does not start. And, an "error code 1501" will occur and the deceleration stop is made at point change in operation.
	2 to 4-axes linear interpolation control	If the positioning data of position command exceeds the software limit is set for the axes in one group, an "error code 1501" will occur and the operation does not start. And, an "error code 1501" will occur and the deceleration stop is made at point change in operation.
Manual control	JOG operation	If it starts in the opposite direction against of OPR from outside the software limit range, an "error code 1501" will occur and the operation does not start. If it is reached to the software stroke limit in operation, an "error code 1502" will occur and the deceleration stop is made so as not to exceed the software stroke limit.
	Incremental feed operation	If the incremental feed amount that exceeds the software stroke limit is set, an "error code 1501" will occur and the operation does not start.
OPR	Proximity dog type	The software stroke limit is not checked.
	Data set type	
	Stopper type	
	Dog cradle type	
	Limit switch combined type	
Other	Scale origin signal detection type	
	Target position change	If the change address exceeds the software stroke limit at target position change function execution, an "error code 1501" will occur and the deceleration stop is made.
	Current value change	If the change address exceeds the software stroke limit, an "error code 1501" will occur and the current value change is not executed.

POINT

- If a continuous path is set in "[Da.0] Operation pattern" and the target address after changing the positioning data exceeds the software stroke limit, an "error code 1501" will occur at positioning data change, and the deceleration stop is made. At this time, if a distance to software stroke limit is shorter than a distance that needed for deceleration, the servo may stop outside the software stroke limit.
- In an error set due to exceeding the software stroke limit, the servo is stopped by "[Da.3] Deceleration time".

If the current value is outside the software stroke limit range (prohibited area), the servo can be moved in the direction of the movement allowed area. However, execute the start operation after resetting the errors.

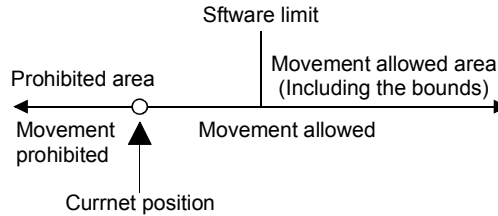

POINT

The software stroke limit is also valid at incomplection of OPR. In the absolute position system, the current position address becomes the outside the movement allowed area differing from a position of the actual machine, the JOG operation might be impossible according to the machine specifications. Execute the current value change to the rough position matched to the actual machine, and then execute the OPR.

10.4.2 Restrictions at absolute position system use

The range that the current value can be restored changes by setting value of the electronic gear and OP address at absolute position system use ("1: Valid" is set in "[Pr.303] Absolute position detection system" of servo parameter). Set the software stroke limit range within the range that the current value can be restored as follows.

- Electronic gear numerator > Electronic gear denominator

$$\begin{aligned}
 \text{"[Pr.4] Software stroke limit upper limit value" (Note-2)} &\cong \left(\frac{2147483647}{\text{"[Pr.0] Electronic gear numerator"}} \right)^{\text{(Note-1)}} \times \text{"[Pr.2] Electronic gear denominator"} + \text{"[Pr.52] OP address"}^{\text{(Note-3)}} \\
 \text{"[Pr.6] Software stroke limit lower limit value" (Note-2)} &\cong \left(\frac{-2147483647}{\text{"[Pr.0] Electronic gear numerator"}} \right)^{\text{(Note-1)}} \times \text{"[Pr.2] Electronic gear denominator"} + \text{"[Pr.52] OP address"}^{\text{(Note-3)}}
 \end{aligned}$$

- Electronic gear numerator ≤ Electronic gear denominator

$$\begin{aligned}
 &\text{"[Pr.4] Software stroke limit upper limit value" (Note-2)} \\
 &\text{"[Pr.6] Software stroke limit lower limit value" (Note-2)} \\
 &\text{"[Pr.52] OP address"}^{\text{(Note-3)}} \leq \text{or} \leq 2147483647 + \text{"[Pr.52] OP address"}^{\text{(Note-3)}}
 \end{aligned}$$

(Note-1): Fractions omitted

(Note-2): "-2147483648 to 2147483647" can be set when the calculated result is outside the settable range "-2147483648 to 2147483647".

(Note-3): Use "[Pr.52] OP address" set at OPR for the setting range check at first PLC READY ON.

An error will occur if the outside the settable range is set. The error occurrence timing and the operation are shown below.

(1) At OPR start

The above setting range is checked. An "error code 1101" will occur if the outside the settable range is set, and the OPR does not start. ("OPR request (Md.9) Status 1: b0)" turns ON.)

(2) At first PLC READY ON (OPR completion in the absolute position system)

The above setting range is checked. An "error code 1101" will occur if the outside the settable range is set, and the current value is not restored. (The current value is set to "0", and "OPR request (Md.9) Status 1: b0)" turns ON.)

10.4.3 Data used for control

Set the following parameters for the software stroke limit function.

Refer to Section 6.3 to 6.8 for the buffer memory address and details.

	Symbol	Item	Details
Parameter	Pr.4	Software stroke limit upper limit value	Set the upper limit value for software stroke limit.
	Pr.6	Software stroke limit lower limit value	Set the lower limit value for software stroke limit.

⚠ CAUTION

- The unlimited length feed cannot be executed in QD74MH. (The software stroke limit cannot be invalidated.)
The moveable range of QD74MH is "-2147483648 to 2147483647". Return to within the moveable range by JOG, etc. if it exceeds the moveable range.

POINT

If the upper software stroke limit value is the lower value or less, an "error code 1504" will occur at positioning start.

10.5 Backlash Compensation Function

This function is used to compensate the backlash amount in the mechanical system.

10.5.1 Control details

When the backlash compensation amount is set, an extra amount of command aqipment to the set backlash amount is output every time the movement direction changes.

The backlash compensation is executed at OPR control.

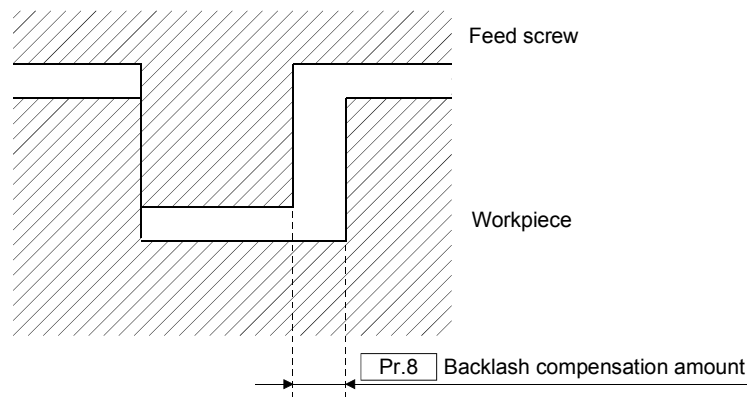

POINT
 Set "[Pr.8] Backlash compensation amount" by encoder pulse unit (PLS unit of instruction to servo amplifier).

10.5.2 Data used for control

Set the following parameters for the backlash compensation function.
 Refer to Section 6.3 to 6.8 for the buffer memory address and details.

	Symbol	Item	Details
Parameter	Pr.8	Backlash compensation amount	Set the backlash compensation amount.

10.6 Speed Limit Function

This function is used to limit the command speed to the speed limit value when the command speed in control exceeds the "speed limit value".

10.6.1 Control details

The relation between the speed limit function and each control is shown below.

Control		Speed limit function	Set item
OPR control	OPR control	○	[Pr.10] Speed limit value
Positioning control	Position control	○	
	1-axis linear control	○	[Pr.10] Speed limit value
Manual control	JOG operation	○	[Pr.10] Speed limit value
	Incremental feed operation	○	[Pr.26] Linear interpolation speed limit value

○: Valid

(1) Speed clamp

The each axis speed is limited with the speed limit value. When the axis speed exceeds the speed limit value set in the each axis, the axis speed is clamped with the speed limit value.

A "warning code 11001" will occur by executing the speed clamp. (However, a warning will occur at positioning start. It will not occur when the speed reached the speed limit value.)

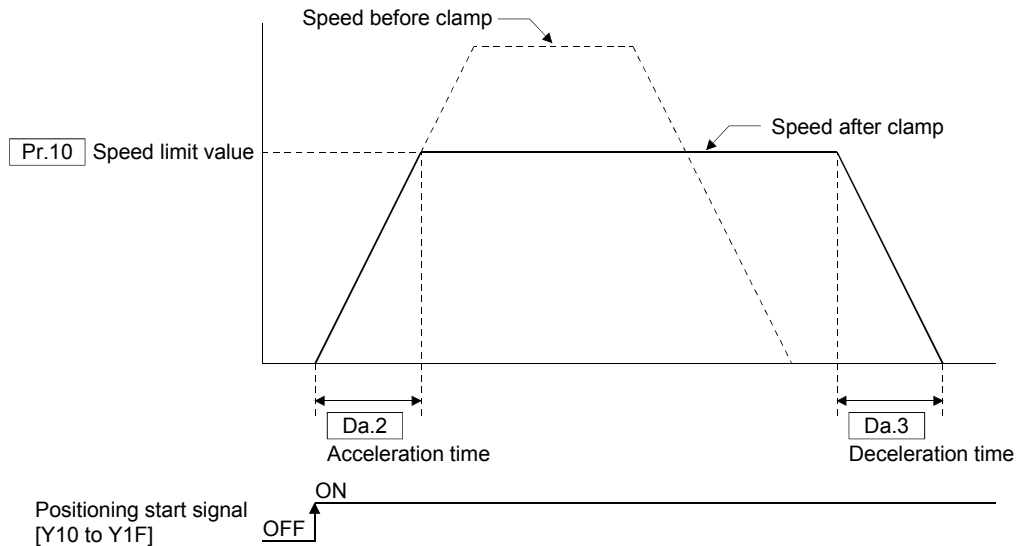

Refer to Section 8.3.5 for the speed of the linear interpolation control.

10.6.2 Data used for control

Set the following parameters for the speed limit function.

Refer to Section 6.3 to 6.8 for the buffer memory address and details.

	Symbol	Item	Details
Parameter	Pr.10	Speed limit value	Set the maximum speed for each axis.
	Pr.26	Linear interpolation speed limit value	Set the maximum speed at the linear interpolation control.

10.7 Acceleration/Deceleration Control

This function is used to adjust the acceleration/deceleration when each control is executed.

10.7.1 Control details

The relation between the acceleration/deceleration control and each control is shown below.

Control		Acceleration/deceleration control	Set item
OPR control	OPR control	○	[Pr.58] OPR acceleration time
Positioning control	Position control	1-axis linear control	[Pr.59] OPR deceleration time
		2 to 4-axes linear interpolation control	[Da.2] Acceleration time [Da.3] Deceleration time
Manual control	JOG operation	○	[Pr.82] JOG operation acceleration time
	Incremental feed operation	○	[Pr.83] JOG operation deceleration time

○: Valid

(1) Linear acceleration/deceleration

The linear acceleration/deceleration is executed as follows.

Set the time to reaching to "[Pr.10] Speed limit value" in "[Da.2] Acceleration time" or "[Da.3] Deceleration time".

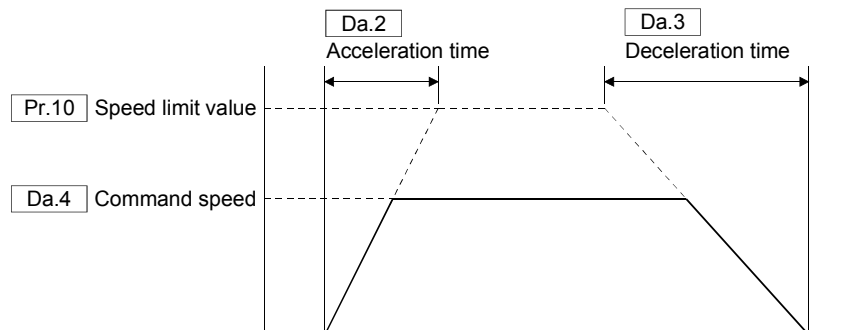

(2) S-curve acceleration/deceleration

The smooth acceleration/deceleration is executed by setting S-curve acceleration/deceleration. At this time, the actual acceleration and actual deceleration time make the profile be longer.

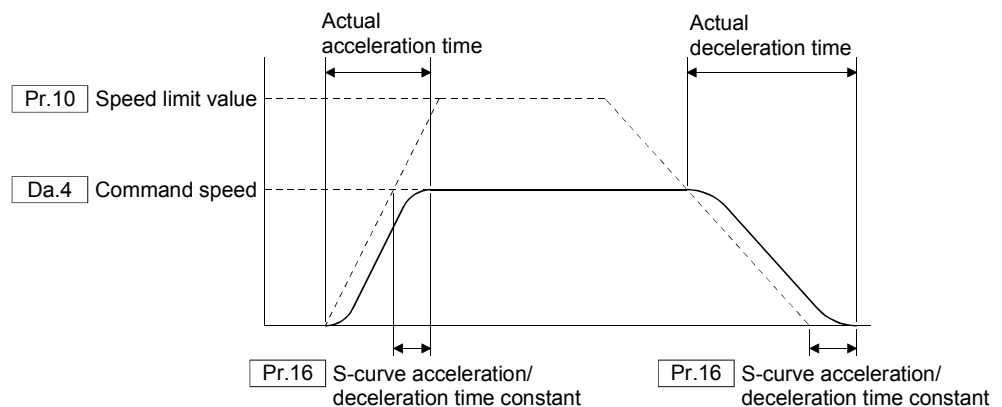

10.7.2 Data used for control

Set the following parameters and control data used for the acceleration/deceleration control.

Refer to Section 6.3 to 6.8 for the buffer memory address and details.

	Symbol	Item	Details
Parameter	Pr.15	Acceleration/deceleration method	Select the acceleration/deceleration method.
	Pr.16	S-curve acceleration/deceleration time constant	Set the time constant for S-curve acceleration/deceleration.
	Pr.58	OPR acceleration time	Set the acceleration time at the OPR.
	Pr.59	OPR deceleration time	Set the deceleration at the OPR.
	Pr.82	JOG operation acceleration time	Set the acceleration time for JOG operation.
	Pr.83	JOG operation deceleration time	Set the deceleration time for JOG operation.
Positioning data	Da.2	Acceleration time	Set the acceleration time.
	Da.3	Deceleration time	Set the deceleration time.

10.8 Stop Control

10.8.1 Control details

The operating axis stops by setting "1" in "[Cd.3] Axis stop". (Errors and warnings are not output.) The operation does not resume even if "1" is set again in "axis stop". The deceleration time used for stopping for stop axis is "[Da.3] Deceleration time". If the axis stop is executed in positioning, the "Positioning complete signal ([Md.10] Status 2: b0)" does not turn ON.

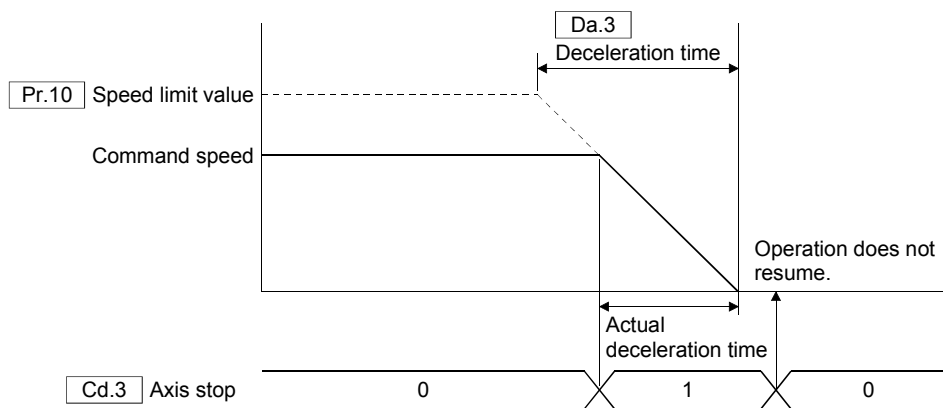

POINT
 If S-curve acceleration/deceleration is set, "[Pr.16] S-curve acceleration/ deceleration time constant" is always valid. Therefore, stop as well will use the S-curve acceleration/deceleration.

The operation for when the axis sudden stop or forced stop is commanded in stop control is shown below.

Control	Input	Operation
In axis stop control	"1" is set in "[Cd.4] Axis sudden stop".	The sudden stop control is executed.
	The forced stop is commanded.	The forced stop control is executed.

10.8.2 Data used for control

Set the following control data for the stop control.

Refer to Section 6.3 to 6.8 for the buffer memory address and details.

	Symbol	Item	Details
Control data	Cd.3	Axis stop	Stop the operating axis.

10.9 Sudden Stop Control

10.9.1 Control details

The operating axis stops abruptly by setting "1" in "[Cd.4] Axis sudden stop ". (Errors and warnings are not output.) The operation does not resume even if "1" is set again in "axis stop".

The deceleration time used for stopping for sudden stop axis is "[Pr.17] Sudden stop deceleration time". If the axis sudden stop is executed in positioning, the "Positioning complete signal ([Md.10] Status 2: b0)" does not turn ON.

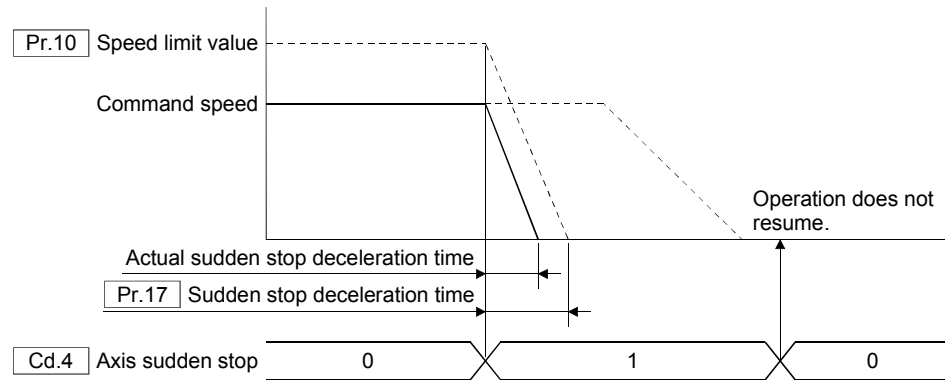

POINT

- (1) If S-curve acceleration/deceleration is set, the S-curve acceleration/ deceleration time constant is always valid. Therefore, sudden stop as well will use the S-curve acceleration/deceleration.
- (2) The sudden stop control is executed by setting "1" in "[Cd.4] Axis sudden stop" in deceleration stop of positioning.
- (3) When the sudden stop time is longer than the stop time ("[Pr.83] JOG operation deceleration time", "[Pr.59] OPR deceleration time"), a "Warning code 11002" will occur at axis sudden stop command, and then the sudden stop time is cramped with the stop time.

The operation when the axis stop or forced stop is commanded in sudden stop control is shown below.

Control	Input	Operation
Axis sudden stop control	"1" is set in "[Cd.3] Axis stop".	It is ignored.
	The forced stop is commanded.	The forced stop control is executed.

10.9.2 Data used for control

Set the following control data for the sudden stop control.

Refer to Section 6.3 to 6.8 for the buffer memory address and details.

	Symbol	Item	Details
Control data	Cd.4	Axis sudden stop	Stop the operating axis suddenly.

10.10 Forced Stop Control

10.10.1 Control details

Set the command speed to "0" at forced stop. When the forced stop command is input to the servo amplifier from the controller, the base circuit is shut off and the dynamic brake operates to bring the servomotor to stop.

Refer to the "Servo amplifier Instruction Manual" for the dynamic brake characteristics.

The current position is updated in forced stop. Therefore, the origin coordinate processing such as OPR is not necessary at forced stop removing.

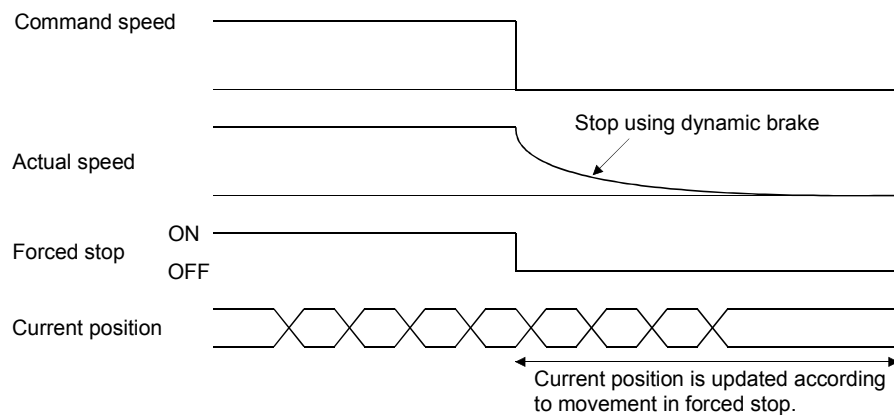

The external forced stop input by external 24VDC or the forced stop input signal [Y2] with input signal from PLC CPU is used to execute the forced stop.

Valid/invalid of the external forced stop can be selected in "[Pr.101] External forced stop selection".

The forced stop input signal [Y2] with input signal from PLC CPU is valid regardless of 'valid/Invalid' of the external forced stop, and it operates with positive logic.

(The forced stop is operated by the signal ON, and it is released by the signal OFF.)

The operation when the stop or sudden stop is commanded in sudden stop control is shown below.

Control	Input	Operation
Axis forced stop control	"1" is set in "[Cd.3] Axis stop".	It is ignored.
	"1" is set in "[Cd.4] Axis sudden stop".	

10.10.2 Data used for control

Set the following control data for the external forced stop control by external 24VDC.
Refer to Section 6.3 to 6.8 for the buffer memory address and details.

There are no set parameters for the forced stop input signal [Y2] with input signal from PLC CPU.

	Symbol	Item	Details
Parameter	Pr.101	External forced stop selection	Select "Valid/Invalid" of the forced stop input by external 24VDC.

Check the following monitor data for the status of the forced stop.

Refer to Section 6.3 to 6.8 for the buffer memory address and monitor details.

	Symbol	Item	Details
Monitor data	Md.103	Forced stop input status	The status of the forced stop input can be stored.

10.11 Command In-position Function

This function is used to check the remaining distance to the stop position at automatic deceleration of positioning control, and to turn ON the signal. This signal is called the "Command in-position ([Md.10] Status 2: b1)". This signal is used as a front-loading signal indicating beforehand the completion of the position control.

10.11.1 Control details

When the command remaining distance (difference between the positioning address and feed current value) becomes equal to or less than "[Pr.20] Command in-position range" "Command in-position ([Md.10] Status 2: b1)" is turned ON.

This function is valid at only last positioning data execution in positioning control (1-axis linear, 2-4 axes linear interpolation). Therefore, it does not turn ON at positioning data execution on the way.

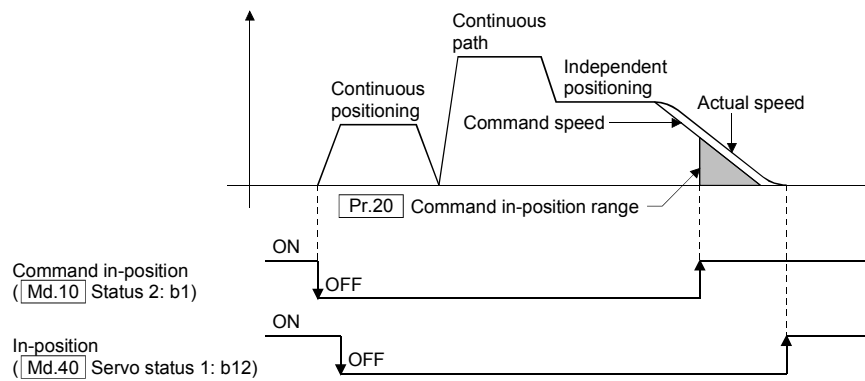

"Command in-position ([Md.10] Status 2: b1)" does not turn ON at the point on the way of the continuous positioning.

Use the independent positioning to start the next positioning after confirming the command in-position.

ex.) When the positioning is started after confirming the 1-axis command in-position signal ON.

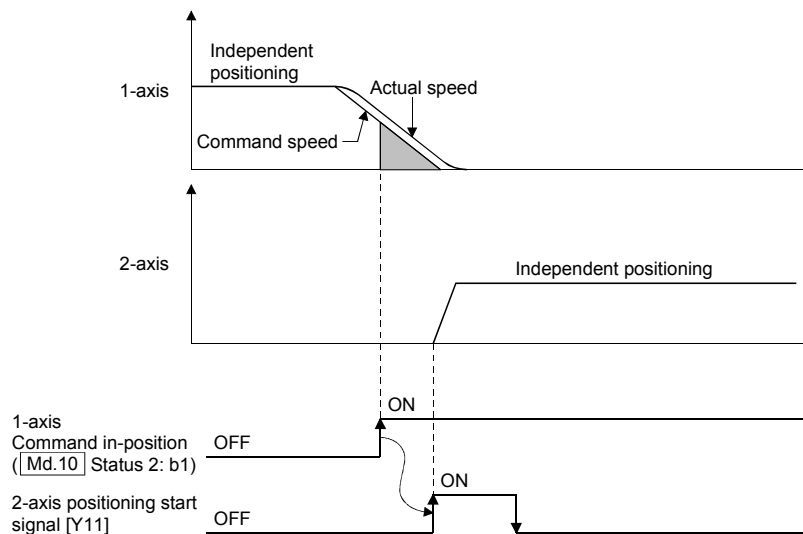

When the remaining distance of all interpolation axes becomes to within the command in-position range at interpolation control, "Command in-position (Md.10 Status 2: b1)" of all axes turn ON.

"Command in-position" signal turns OFF in the following cases.

- At positioning start
- At OPR start
- At manual operation start

10.11.2 Data used for control

Set the following parameters for the command in-position function.
Refer to Section 6.3 to 6.8 for the buffer memory address and details.

	Symbol	Item	Details
Parameter	Pr.20	Command in-position range	Set the remaining distance that turns the command in-position ON.

The command in-position signal is stored in the following buffer memory address.
Refer to the Section 6.3 to 6.8 for the buffer memory address and monitoring details.

	Symbol	Item	Details
Monitor data	Md.10	Status 2	b1: Command in-position

10.12 Pausing Function

10.12.1 Control details

The relation between the pausing function and the each control is shown below.

Control		Pausing function	Set item
Positioning control	Position control	1-axis linear control	[Cd.5] Pausing
		2 to 4-axes linear interpolation control	
Manual control	JOG operation	○	
	Incremental feed operation	○	
OPR	Proximity dog type	×	
	Data set type	×	
	Stopper type	×	
	Dog cradle type	×	
	Limit switch combined type	×	
	Scale origin signal detection type	×	

○: Valid ×: Invalid

The positioning is paused by setting "1" in "[Cd.5] Pausing". "Pausing ([Md.10] Status 2: b2)" signal turns ON in positioning stop. The operation is resumed by setting "0".

CAUTION

● Do not command "[Cd.5] Pausing" for the control of pausing disable. Operation may cause errors.

Deceleration is started according to the sudden stop time to stop by "[Cd.5] Pausing".

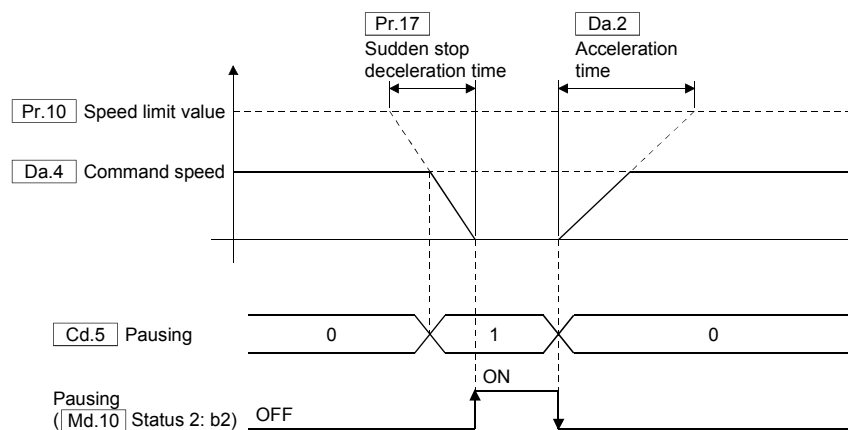

POINT

When the sudden stop time is longer than the stop time ("[Pr.83] JOG operation deceleration time", "[Pr.59] OPR deceleration time"), a "Warning code 11002" will occur at axis sudden stop command, and the sudden stop time is cramped with the stop time.

When the pausing is removed in deceleration, the positioning is resumed without waiting for the stop. At this time, "Pausing ([Md.10] Status 2: b2)" does not turn ON.

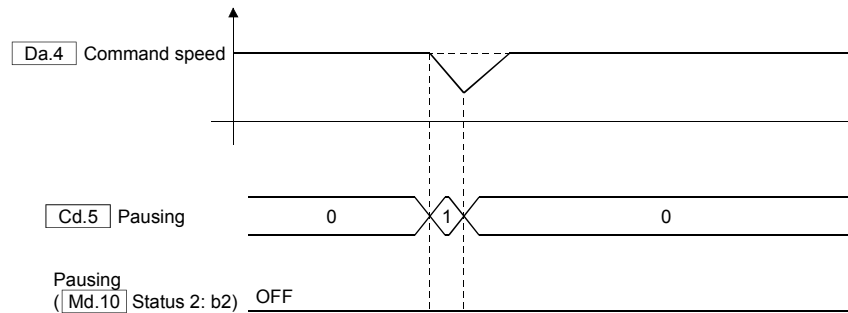

- POINT**
- (1) When "[Cd.3] Axis stop" or "[Cd.4] Axis sudden stop" is executed in pausing, the positioning does not resume even if the pausing is removed.
 - (2) If S-curve acceleration/deceleration are set, the S-curve acceleration/ deceleration time constant" are always valid. Therefore, the sudden stop or acceleration will use S-curve acceleration/deceleration.
 - (3) If the positioning is started by setting "1" in "[Cd.5] Pausing", an "error code 1013" will occur, and the operation does not start. Start after removing the pausing.
 - (4) It is ignored, even if the positioning is started while paused in positioning control.
 - (5) If "1" is set in "pausing" for even by 1 axis in the linear interpolation group, all axes in one group are terminated. And, the operation resumes by removing the pausing of all axes in one group. All axes in one group turn ON in pausing.
 - (6) Pausing is also valid in positioning deceleration. If pausing is turned OFF after the sudden stop by pausing, the deceleration is started after the acceleration is executed to the speed in deceleration. However, because the acceleration/ deceleration for pausing is executed more extra than normal deceleration, the sudden stop is executed when it reached the target position after pausing.
 - (7) Pausing is also valid in deceleration by the axis stop. The operation stops with the sudden stop by pausing. After that, the positioning does not resume even if the pausing is turned OFF.

10.12.2 Data used for control

Set the following control data for the pausing function.

Refer to Section 6.3 to 6.8 for the buffer memory address and details.

	Symbol	Item	Details
Control data	Cd.5	Pausing	Command the pausing.

The pausing flag is stored in the following buffer memory.

Refer to the Section 6.3 to 6.8 for the buffer memory address and monitoring details.

	Symbol	Item	Details
Monitor data	Md.10	Status 2	b2: Pausing

10.13 Torque Limit Function

This function is used to limit the generated torque to the torque limit value when the torque of the servomotor exceeds the torque limit value.

10.13.1 Control details

The relation between the torque limit function and the each control is shown below.

Control		Torque limit function	Set item
OPR control	OPR control	○	
Positioning control	Position control	1-axis linear control	○
		2 to 4-axes linear interpolation control	○
Manual control	JOG operation	○	<div style="border: 1px solid black; padding: 2px;">Cd.12</div> Forward rotation torque limit value <div style="border: 1px solid black; padding: 2px;">Cd.13</div> Reverse rotation torque limit value
	Incremental feed operation	○	

○: Valid

When "1" is set in "

Cd.11

 Torque limit request", the torque is limited by the torque limit values set in "

Cd.12

 Forward rotation torque limit value" and "

Cd.13

 Reverse rotation torque limit value". At this time, "Torque limit (

Md.40

 Servo status 1: b13)" turns ON. If the actual torque does not reach to the torque limit value even if "torque limit request" is "1", "torque limit" does not turn ON.

The torque limit function can also be implemented in acceleration or deceleration. Also, this function can be used in servo ON even not positioning.

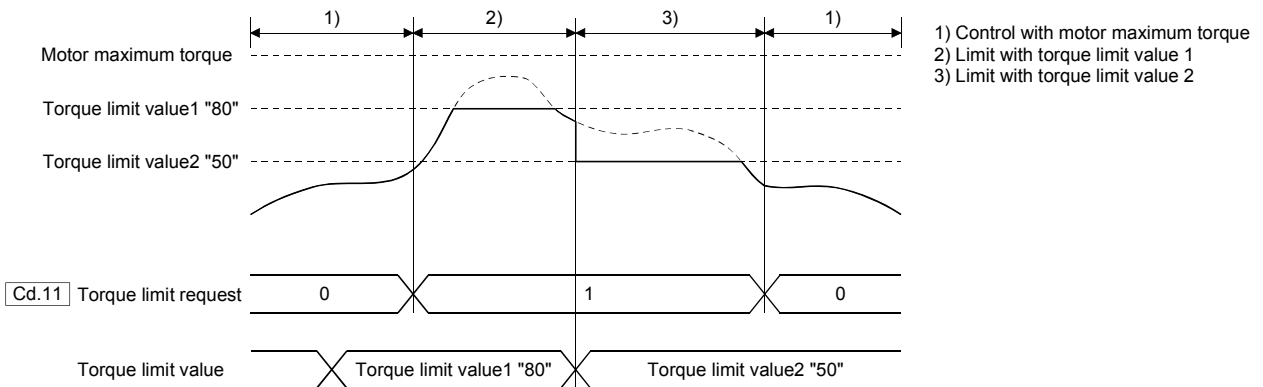

POINT

- (1) "

Cd.12

 Forward rotation torque limit value" and "

Cd.13

 Reverse rotation" can be separately set in the torque limit function. However, "

Cd.11

 Torque limit request" is valid to both of the forward rotation/reverse rotation, so set the same value normally to both of them.
- (2) When "

Cd.11

 Torque limit request" is "0", the torque limit value is set to the motor maximum torque.

10.13.2 Data used for control

Set the following control data for the torque limit function.

Refer to Section 6.3 to 6.8 for the buffer memory address and details.

	Symbol	Item	Details
Control data	Cd.11	Torque limit request	Command the torque limit request.
	Cd.12	Forward rotation torque limit value	Set the limiting torque generated in the CW direction when the servo motor is executing in the CCW direction.
	Cd.13	Reverse rotation torque limit value	Set the limiting torque generated in the CCW direction when the servo motor is executing in the CW direction.

Check the following monitor data for the status of the torque limit.

Refer to Section 6.3 to 6.8 for the buffer memory address and monitor details.

	Symbol	Item	Details
Monitor data	Md.40	Servo status 1	b13: Torque limit

10.14 Speed Change Function

This function is used to change the speed in control to a newly designated speed at any timing.

10.14.1 Control details

The relation between the speed change function and the each control is shown below.

Control		Speed Change function	Set item	
OPR control	OPR control	×	Cd.16 New speed value	
Positioning control	Position control	1-axis linear control		○
		2 to 4-axes linear interpolation control		○
Manual control	JOG operation	○		
	Incremental feed operation	○		

○: Valid ×: Invalid

When "1" is set in "Cd.15 Speed change request", it is changed to the speed set in "Cd.16 New speed value".

The speed change function can also be implemented in acceleration or deceleration.

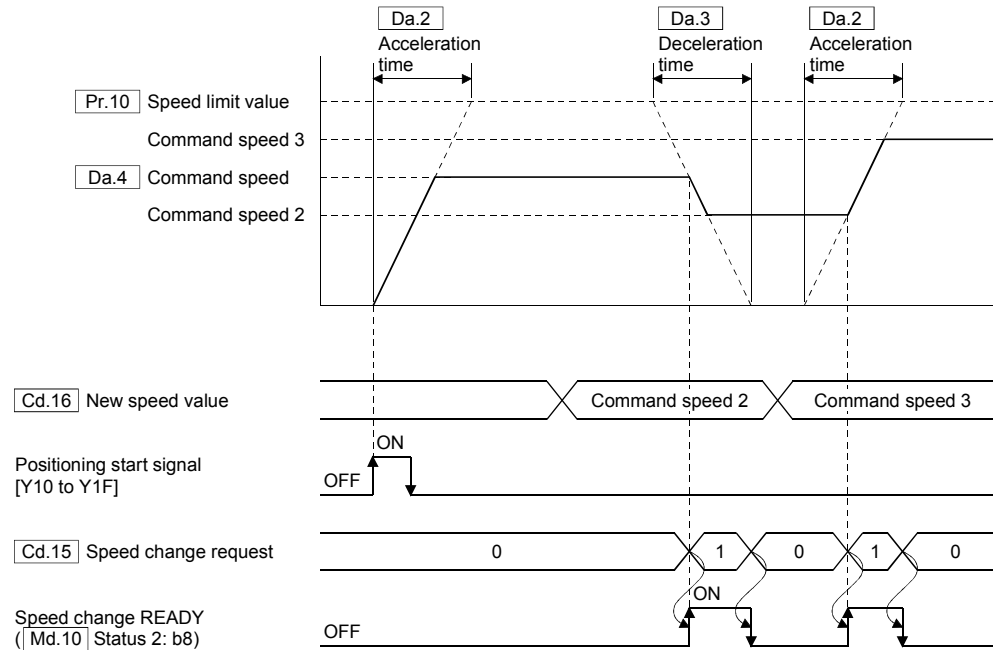

A "Warning code 11011" will occur and the speed change does not execute in the following cases.

- In operation stop
- In deceleration by the stop command, sudden stop command or alarm
- In OPR
- In current value change
- In pausing

10.14.2 Precautions

- (1) The pausing command was given to make a stop after a speed change that had been made in position control. After that, the speed when the pausing is removed is the new speed value.

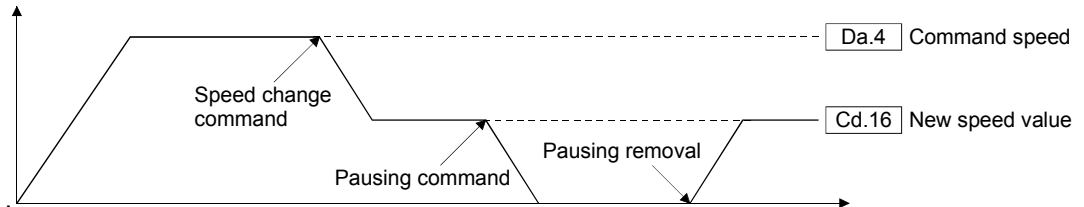

- (2) When the value set in "[Cd.16] New speed value" is more than the speed limit value, the speed is cramped with the speed limit value. In this case, a "Warning code 11001" will occur at speed change request.
- (3) Set the required speed in the reference axis to change the speed at interpolation control.
- (4) The new speed is valid in execution of the positioning data for which the speed was changed. Even if the speed is changed to the new speed by executing the speed change at continuous positioning control and continuous path control, the control is executed with the previously set speed at the changeover to the next positioning data.

10.14.3 Data used for control

Set the following control data for the speed change function.
Refer to Section 6.3 to 6.8 for the buffer memory address and details.

	Symbol	Item	Details
Control data	Cd.15	Speed change request	Execute the speed change request.
	Cd.16	New speed value	Set the speed after the change.

Check the following monitor data for the status of the speed change.
Refer to Section 6.3 to 6.8 for the buffer memory address and monitor details.

	Symbol	Item	Details
Monitor data	Md.10	Status 2	b8: Speed change READY

10.15 Acceleration/Deceleration Time Change Function

10.15.1 Control details

The relation between the acceleration/deceleration time change function and the each control is shown below.

Control		Acceleration/deceleration time change function	Set item	
OPR control	OPR control	×	[Cd.19] New acceleration time value [Cd.21] New deceleration time value	
Positioning control	Position control	1-axis linear control		○
		2 to 4-axes linear interpolation control		○
Manual control	JOG operation	○		
	Incremental feed operation	○		

○: Valid ×: Invalid

When "1" is set in "[Cd.18] Acceleration time change request" or "[Cd.20] Deceleration time change request", it is changed to the acceleration/deceleration time set in "[Cd.19] New acceleration time value" or "[Cd.21] New deceleration time value". The acceleration/deceleration time change can also be implemented in acceleration or operation.

(1) When the acceleration time is changed in acceleration

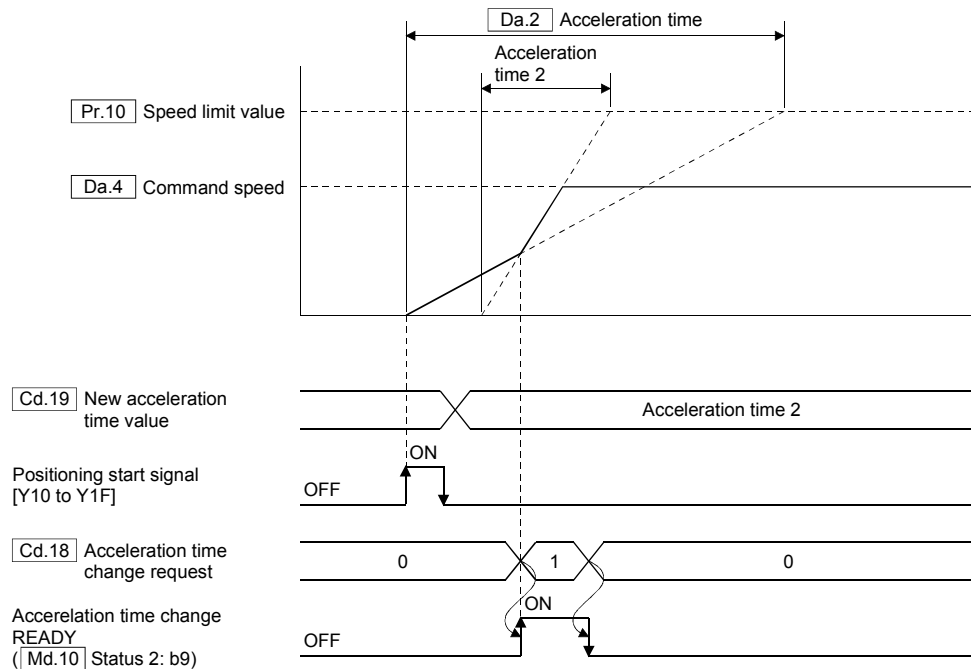

A "Warning code 11012" or "Warning code 11013" will occur and the acceleration/deceleration time change does not execute in the following cases.

- In operation stop
- In deceleration
- In OPR
- In current value change
- In pausing

(2) When the speed change function is used simultaneously

When this function and the speed change function are simultaneously used, the speed change is executed after the acceleration/deceleration time change.

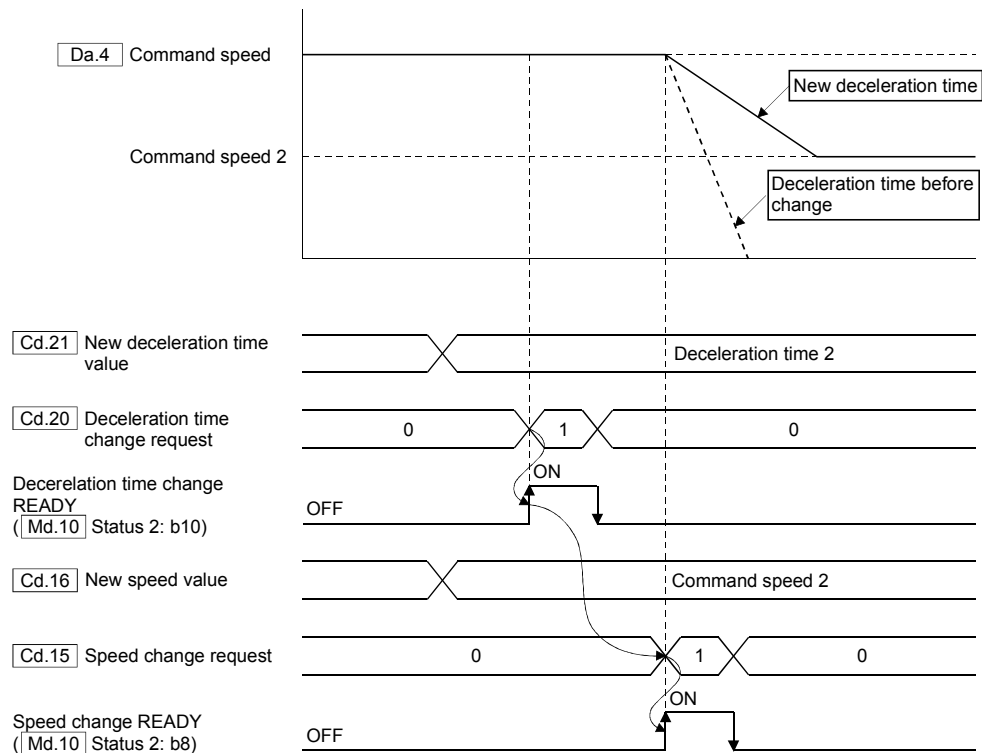

10.15.2 Precautions

- (1) The new acceleration/deceleration time is valid in execution of the positioning data for which the acceleration/deceleration was changed. Even if the acceleration/deceleration is changed to the new acceleration/deceleration by executing the acceleration/deceleration change at continuous positioning control and continuous path control, the control is executed with the previously set acceleration/deceleration at the changeover to the next positioning data.
- (2) Even if the acceleration/deceleration time change is set to disable after the new acceleration/deceleration time is validated, the positioning data for which the new acceleration/deceleration time was validated will continue to be controlled with that value. (The next positioning data will be controlled with the previously set acceleration/deceleration time.)

10.15.3 Data used for control

Set the following control data for the acceleration/deceleration time change function.
Refer to Section 6.3 to 6.8 for the buffer memory address and details.

	Symbol	Item	Details
Control data	Cd.18	Acceleration time change request	Execute the acceleration time change request.
	Cd.19	New acceleration time value	Set the acceleration time after the change.
	Cd.20	Deceleration time change request	Execute the deceleration time change request.
	Cd.21	New deceleration time value	Set the deceleration time after the change.

Check the following monitor data for the status of the acceleration/deceleration time change.

Refer to Section 6.3 to 6.8 for the buffer memory address and monitor details.

	Symbol	Item	Details
Monitor data	Md.10	Status 2	b9: Acceleration time change READY b10: Deceleration time change READY

10.16 Target Position Change Function

This function is used to change the target position in position control (1-axis linear control) to a newly designated target position at any timing.

Set an absolute address as the change value in the absolute positioning system. And, set a movement direction and movement amount from start position in the incremental positioning system.

10.16.1 Control details

The relation between the target position change function and the each control is shown below.

Control		Target position change function	Set item
OPR control	OPR control	×	—
Positioning control	Position control	1-axis linear control	[Cd.24] New target position value
		2 to 4-axes linear interpolation control	—
Manual control	JOG operation	×	—
	Incremental feed operation	×	—

○: Valid ×: Invalid

When "1" is set in "[Cd.23] Target position change request", it is changed to the position set in "[Cd.24] New target position value".

The target position change function can also be implemented in acceleration or deceleration.

The target position change cannot be changed in the linear interpolation operation.

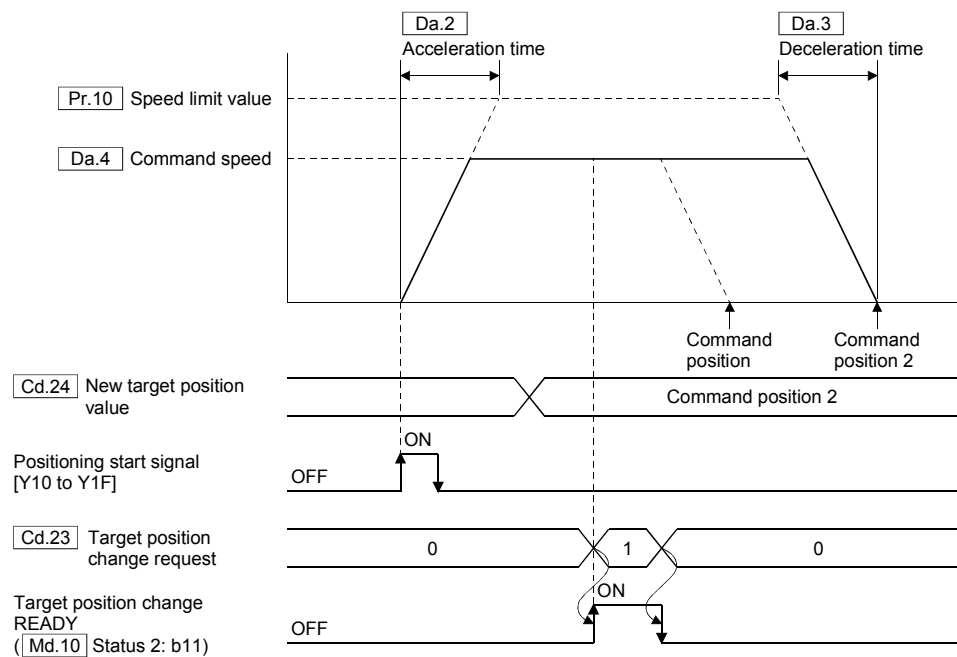

When the position change to the movement direction from the current value is executed in deceleration stop, the axis is accelerated again and positioned.

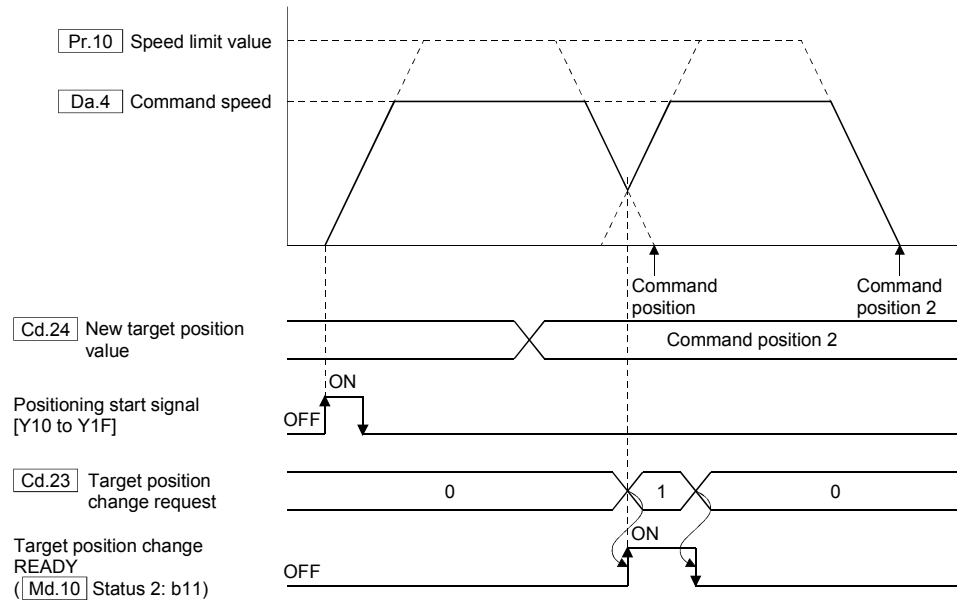

The operation for when the axis passed the change position by position change, or the deceleration stop position passes the change position can be selected in "[Pr.23 Target position change overrun processing selection]" ("Stop by the error" or "Return to change position after deceleration stop").

If "Stop by the error" is selected, an "error code 1024" will occur after turning the target position change READY ON at target position change request.

If "Return to change position after deceleration stop" is selected, the operation is shown next page.

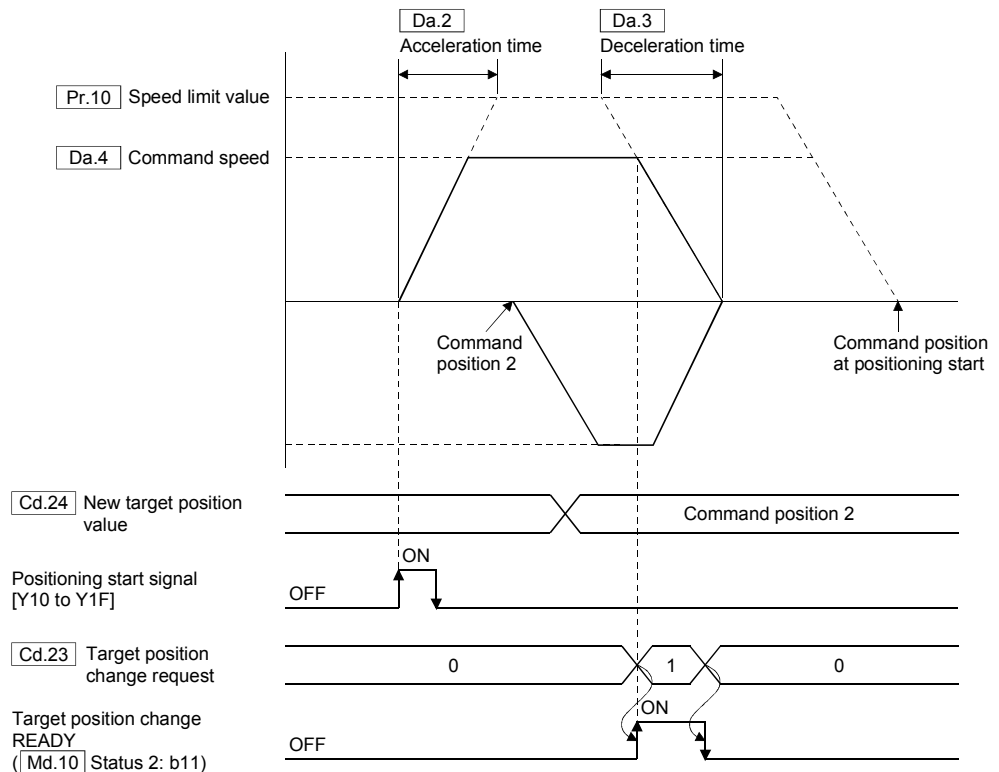

A "Warning code 11014" will occur and the position change is not executed in the following cases.

- In operation stop
- In deceleration by the stop command, sudden stop command or alarm
- In JOG operation
- In OPR
- In linear interpolation
- In current value change
- In pausing

10.16.2 Data used for control

Set the following parameters and control data for the target position change function. Refer to Section 6.3 to 6.8 for the buffer memory address and details.

	Symbol	Item	Details
Parameter	Pr.23	Target position change overrun processing selection	Set the process when a stop position exceeds a command position for position change.
Control data	Cd.23	Target position change request	Execute the target position change request.
	Cd.24	New target position value	Set the target position after the change.

Check the following monitor data for the status of the target position change function. Refer to Section 6.3 to 6.8 for the buffer memory address and monitor details.

	Symbol	Item	Details
Monitor data	Md.10	Status 2	b11: Target position change READY

10.17 Current Value Change Function

This function is used to change the current position of stopped axis to the address set in "[Cd.28] New current value".

10.17.1 Control details

Set the new address in "[Cd.28] New current value". The current value is changed by setting "9003" in "[Cd.2] Start method" to turn the positioning start signal [Y10 to Y1F] ON.

If the data outside the stroke limit is set in "new current value", an "error code 1501" will occur.

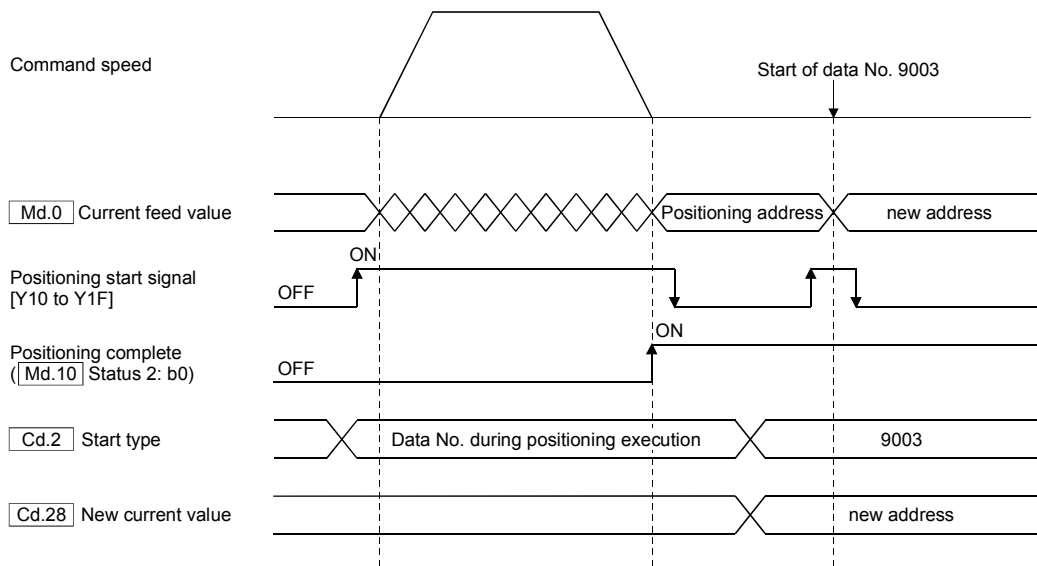

POINT

If the system's power cycle is executed after current value change in the absolute position system, it returns to the address before current value change.

CAUTION

- If the operation to one direction within the software stroke limit repeats using the current value change function, the current value may not be correctly restored in the absolute position system. Do not execute such positioning in the absolute position system.

10.17.2 Data used for control

Set the following control data for the current value change function. Refer to Section 6.3 to 6.8 for the buffer memory address and details.

	Symbol	Item	Details
Control data	Cd.2	Start method	Set the start method (9003: New current value)
	Cd.28	New current value	Set the address after change.

10.18 External Signal Logic Selection

10.18.1 Control details

The upper hardware stroke limit (FLS), the lower hardware stroke limit (RLS), and the dog signal (DOG) can be input by using the input signal of the servo amplifier. And, the logic selection of input signal is possible. Select the negative logic or positive logic in "[Pr.31] External input signal logic selection".

(1) Negative logic

(a) Input signal is OFF.

1) FLS, RLS → Limit switch is in operation. (Stroke prohibited area)

2) DOG → OFF

(b) Input signal is ON.

1) FLS, RLS → Limit switch is removed. (Stroke movement allowed area)

2) DOG → ON (DOG detection)

(2) Positive logic

Opposite of the negative logic

⚠ CAUTION

- When the hardware stroke limit is required to be wired, ensure to wire it in the negative logic using B-contact. If it is set in positive logic using A-contact, the hardware stroke limit may not be detected even if the signal wires are disconnected.

10.18.2 Data used for control

Set the following parameters for the external signal logic selection.

Refer to Section 6.3 to 6.8 for the buffer memory address and details.

	Symbol	Item	Details
Parameter	Pr.31	External input signal logic selection	Select the logic of the external input signal.

10.19 Operation Setting for Incompletion of OPR Function

This function is used to select whether positioning control is operated or not, when OPR request flag is ON.

10.19.1 Control details

An "Error code1090" will occur if the positioning control is executed with the "OPR request flag ([Md.9] Status 1: b0)" has been turned ON, when "0: Positioning control is not executed" (initial value in "[Pr.66] Operation setting for incompletion of OPR") is selected.

The manual control and OPR can be implemented.

The positioning control can be executed even if OPR request flag is ON, when "1: Positioning control is executed." is selected.

CAUTION

- Do not execute the positioning control with the OPR request flag has been turned ON in the axes used in the positioning.
Failure to observe this could lead to an accident such as a collosion.

The following table shows whether the positioning can be started at operation setting for incompletion of OPR.

Control details		[Pr.66] Operation setting for incompletion of OPR	
		"0: Positioning control is not executed." and "OPR request flag ON"	"1: Positioning control is executed." and "OPR request flag ON"
Positioning control	1-axis linear control	×	○
	2 to 4-axes interpolation control	×	○
Manual control	JOG operation	○	○
	Incremental feed operation	○	○
OPR	Proximity dog type	○	○
	Data set type	○	○
	Stopper type	○	○
	Dog cradle type	○	○
	Limit switch combined type	○	○
	Scale origin signal detection type	○	○
Other	Current value change	○	○

○: Applicable ×: Not applicable

10.19.2 Data used for control

Set the following parameters for the operation setting for incompleteness of OPR function.

Refer to Section 6.3 to 6.8 for the buffer memory address and details.

	Symbol	Item	Details
Parameter	Pr.66	Operation setting for incompleteness of OPR	Set whether the positioning control is executed or not (When the "OPR request" (<u>Md.9</u> Status 1: b0)" is ON.)

10.20 Axis Error Reset

10.20.1 Control details

The error status is removed after executing the following processing by setting "1" in "[Cd.0] Axis error reset" of the buffer memory for axis error reset.

- Error detection signal [X1] OFF
- "[Md.6] Error code" clear
- "[Md.7] Error detail" clear
- Bit OFF corresponding axis of error reset command set in "[Md.100] Axis error status"
- Error reset transmission to the servo amplifier
- Warning detection signal [X2] OFF
- "[Md.8] Warning code" clear
- Bit OFF corresponding axis of error reset command set in "[Md.101] Axis warning status"

⚠ CAUTION

- The error reset cannot be executed for some servo errors. The error detection of QD74MH cannot be removed even if the error reset is executed at such the servo errors occurrence. Refer to the Servo amplifier Instruction Manuals for details.
- The servo warning cannot be reset even if the error reset is executed in servo warning occurrence. Execute the error reset after eliminating the error cause, and then clear the servo warning of QD74MH.

10.20.2 Data used for control

Set the following control data for the axis error reset.

Refer to Section 6.3 to 6.8 for the buffer memory address and details.

	Symbol	Item	Details
Control data	Cd.0	Axis error reset	Release error that occurs in axis.

10.21 Absolute position system

10.21.1 Control details

In the absolute position system, if machinery position is determined at the system startup, there is no need to execute the OPR because the absolute position is detected at system's power supply ON.

Use the OPR for the determination of machinery position.

POINT

While "OPR request (Pr.9 Status 1: b0)" in ON, the current value becomes "0" at system's power supply ON, and the current value is not restored.

Be sure to execute the OPR when the OPR request turned ON in the absolute position system.

⚠ CAUTION

- When using the absolute position system function, on starting up, and when the Motion controller or absolute value motor has been replaced, always perform a home position return. In the case of the absolute position system, use the PLC program to check the home position return request before performing the positioning control. Failure to observe this could lead to an accident such as a collision.

The "OPR request (Pr.9 Status 1: b0)" turns ON in the following cases.

- 1) The electronic gear ("Pr.0 Electronic gear numerator", "Pr.2 Electronic gear denominator") or the servo parameter "Pr.314 Rotation direction selection" are changed. (First PLC READY ON)
- 2) "Error code 2025" or "Warning code 2143" occurred. (First PLC READY ON)
- 3) "Error code 1201" occurred. (First PLC READY ON)
- 4) The OPR never is executed for the absolute position system. (First PLC READY ON)
- 5) Change the servo parameter "Pr.303 Absolute position detection system" from "0: Invalid (Used in incremental system)" to "1: Valid (Used absolute position detection system)". (First PLC READY ON)
- 6) The OPR is started.
- 7) The setting value of software stroke limit is outside the range. (First PLC READY ON)

POINT

When "0: Invalid (Used in incremental system)" is set in "Pr.303 Absolute position detection system" of servo parameter, the "OPR request (Pr.9 Status 1: b0)" turns ON at every first PLC READY ON.

Select "1: Valid (Used absolute position detection system)" in [Pr.303] Absolute position detection system" of servo parameter to use as the absolute position system.
Be sure to install a battery for retaining the location of the OPR in the servo amplifier.

POINT

When the servo parameter "[Pr.303] Absolute position detection system" is changed from "1: Valid (Used absolute position detection system)" to "0: Invalid (Used in incremental system)", the established machinery position before change becomes invalid. Execute again the OPR to used as the absolute position system.

10.22 Flash ROM Write Function

When the buffer memory data of QD74MH are rewritten from the PLC CPU, the changed data are not saved if the system's power supply is turned OFF.

This function is used to backup by writing the changed data to the flash ROM. The data that was backed up is written to the buffer memory when the system's power supply is turned ON next.

10.22.1 Control details

The flash ROM write is executed by setting "1" in "[Cd.100] Flash ROM write request". "0" is automatically set in "flash ROM write request" by QD74MH after writing.

Important

Do not turn the system's power ON/OFF or resetting PLC CPU in writing to the flash ROM. The flash ROM data may be corrupted.
--

The data that can be written to the flash ROM by flash ROM write are shown below.

- Basic parameters
- OPR parameters
- Manual control parameters
- System parameters
- Positioning data
- Servo parameters

POINT

The absolute position information is automatically backed up in the absolute position system. It is not necessary to back up them by the flash ROM write function.
--

(1) Cautions

- (a) Execute the flash ROM write when the positioning control do not execute (PLC READY signal [Y0] OFF).
- (b) A writing to the flash ROM is up to 100,000 times. If writing exceeds 100,000 times, the writing may be become impossible, and an "error code 1901" will occur.
- (c) The total number of the flash ROM write and parameter initialization with the sequence program after the error reset, system's power supply ON or PLC CPU reset is limiter to up to 25. Writing of the 26th will cause an "error code 1902". Execute the error reset, system's power cycle or PLC CPU reset at error occurrence.
- (d) The flash ROM write can be executed, after the system's power supply ON and the PLC READY signal [Y0] ON. If the flash ROM write is executed without turning ON the PLC READY signal [Y0] after the system's power supply ON, a "warning code 10001" will occur and the flash ROM write cannot be executed.

10.22.2 Data used for control

Set the following control data for the flash ROM write function.
 Refer to Section 6.3 to 6.8 for the buffer memory address and details.

	Symbol	Item	Details
Control data	Cd.100	Flash ROM write request	Write the contents from the buffer memory to the flash ROM

Number of write accesses to flash ROM by the flash ROM write function is stored in the following buffer memory.
 Refer to the Section 6.3 to 6.8 for the buffer memory address and monitoring details.

	Symbol	Item	Details
Monitor data	Md.102	Number of write accesses to flash ROM	Number of write accesses to flash ROM and the number of parameter initializations after the system power supply ON can be stored.

10.23 Parameter Initialization Function

This function is used to return the setting data set in the buffer memory of QD74MH and flash ROM to the factory default.

10.23.1 Control details

The parameter initialization is executed by setting "1" in "[Cd.101] Parameter initialization request". "0" is automatically set in "parameter initialization request" by QD74MH after initialization.

Important

Do not turn the system's power ON/OFF or resetting PLC CPU in parameter initialization. The flash ROM data may be corrupted.
--

The data that can be initialized by the parameter initialization are shown below.

- Basic parameters
- OPR parameters
- Manual control parameters
- System parameters
- Positioning data
- Servo parameters

(1) Cautions

- (a) Execute the parameter initialization when the positioning control do not execute (PLC READY signal [Y0] OFF). An "error code 1903" will occur if it is executed at PLD READY ON.
- (b) A writing to the flash ROM is up to 100,000 times. If writing exceeds 100,000 times, the writing may be become impossible, and an "error code 1901" will occur.
- (c) A PLC CPU reset or system's restart must be executed after the parameter initialization.
- (d) The total number of the flash ROM write and parameter initialization with the sequence program after the error reset, system's power supply ON or PLC CPU reset is limiter to up to 25. Writing of the 26th will cause an "error code 1902". Execute the error reset, system's power cycle or PLC CPU reset at error occurrence.
- (e) A parameter initialization can be executed, after the system's power supply ON and the PLC READY signal [Y0] is turned ON to OFF. If the parameter initialization is executed without turning ON the PLC READY signal [Y0] after the system's power supply ON, a "warning code 10001" will occur and a writing to the parameter initialization cannot be executed.

10.23.2 Data used for control

Set the following control data for the parameter initialization function.
Refer to Section 6.3 to 6.8 for the buffer memory address and details.

	Symbol	Item	Details
Control data	Cd.101	Parameter initialization request	Execute the parameter initialization request stored in the flash ROM

Number of write accesses to flash ROM by the parameter initialization function is stored in the following buffer memory.
Refer to the Section 6.3 to 6.8 for the buffer memory address and monitoring details.

	Symbol	Item	Details
Monitor data	Md.102	Number of write accesses to flash ROM	Number of write accesses to flash ROM and the number of parameter initializations after the system power supply ON can be stored.

10.24 Parameter Change Function

The basic parameters or OPR parameters are taken from the buffer memory at PLC READY ON in QD74MH.

This function is used to change the part of these parameters in PLC READY ON.

10.24.1 Control details

The following parameters are changed by setting "1" in [Cd.1] Parameter change request". "0" will be automatically set in "parameter change request" by QD74MH after changing all parameters.

If there are parameters outside the range at parameter change request, an "error code 1037" will occur and the erroneous parameters cannot be changed. In this case, the all parameters within the setting range changed, and "0" is set in "parameter change request".

Parameters that can be changed by the parameter change request are shown below.

- [Pr.4] Software stroke limit upper limit value
- [Pr.6] Software stroke limit lower limit value
- [Pr.10] Speed limit value
- [Pr.15] Acceleration/deceleration method
- [Pr.16] S-curve acceleration/deceleration time constant
- [Pr.17] Sudden stop deceleration time
- [Pr.20] Command in-position range
- [Pr.23] Target position change overrun processing selection
- [Pr.26] Linear interpolation speed limit value
- [Pr.52] OP address
- [Pr.54] OPR speed
- [Pr.56] Creep speed
- [Pr.58] OPR acceleration time
- [Pr.59] OPR deceleration time
- [Pr.60] OP shift amount
- [Pr.62] OP search limit

POINT

"Parameter change request" is executed for every axis. Set "1" in "[Cd.1] Parameter change request" for target axes to change the parameters for the multiple axes.

10.24.2 Data used for control

Set the following control data for the parameter change function.

Refer to Section 6.3 to 6.8 for the buffer memory address and details.

	Symbol	Item	Details
Control data	Cd.1	Parameter change request	Execute the parameter change request.

11. TROUBLESHOOTING

11.1 Error and Warning Details

Outline for the error codes and warning codes detected by the QD74MH are shown below.

Error/warning code	Details
1 to 999	System error
1000 to 1899	Operation error (1200s errors are used for errors for the absolute position system.)
1900 to 1999	Interface error
2000 to 2099	Servo error
2100 to 2199	Servo warning
11000 to 11999	Operation warning

11.1.1 Errors

Types of errors are shown below.

- System errors by hardware failure, etc.
- Operation errors at operation start or in operation
- Interface errors
- Servo errors detected by servo amplifier

Error code (Md.6) and error detail (Md.7) are represented in decimal. Confirm the error codes by the decimal in the buffer memory.

Axis cannot be started in error occurrence. Eliminate the error cause, and then start the axis after resetting the error. If the axis is started in error occurrence, the error code is unchanged.

(1) System errors (Error code: 1 to 999)

The system errors occur by hardware failure, etc. The system errors cannot be reset. If the multiple system errors occur simultaneously, the smallest number is given to priority.

(2) Operation errors (Error code: 1000 to 1899)

The operation errors occur at the following timing.

If the other errors occur at operation error occurrence, the error code is updated.

(a) At PLC READY ON

The parameters are checked at leading edge (OFF to ON) of PLC READY signal ON [Y0] (at parameter change request). An "error code 1037" will occur if there is a mistake in the parameter setting details.

At that time, the Unit READY signal [X0] does not turn ON. Correct the parameters, and then turn ON the PLC READY signal [Y0] after resetting the error.

- (b) At operation start or in operation
The errors are detected at operation start or in operation such as OPR control, positioning control and JOG operation.
If this error occurs at interpolation operation, the error number is stored in both the reference axis and interpolation axis.
Release the errors by error reset after eliminating the error cause.
- (3) Interface errors (Error code: 1900 to 1999)
The interface errors occur when the interface with hardware or CPU such as the errors at FLASH ROM writing or PLC CPU failure is abnormal.
The interface error is detected as the error for Axis 1.
Execute the error reset for Axis 1 after eliminating the error cause.
If the other errors occur at interface error occurrence, the error code is updated.
- (4) Servo errors (Error code: 2000 to 2099)
The servo errors occur when the hardware such as servo amplifier and servomotor, or the servo parameter are abnormal.
The axis stops by servo OFF at error occurrence.
Execute the error reset after eliminating the error cause for the errors that can be execute the axis error reset by the controller.
Execute the power cycle of the servo amplifier or system after eliminating the error cause for the errors that cannot be executed the axis error reset by the controller.
Refer to the Servo Amplifier Instruction Manual for details of the servo errors.
If the other errors occur at servo error occurrence, the error code is updated.

POINT

Start of positioning, OPR or manual control cannot be executed for the axis in operation error occurrence. Start after reset errors.
--

11.1.2 Warnings

Types of warnings are shown below.

- Servo warnings detected by servo amplifier
- Operation warnings at operation start or in operation

Warning code ([Md.8](#)) is represented in decimal. Confirm the warning codes by the decimal in the buffer memory.

(1) Servo warnings (Warning code: 2100 to 2199)

The servo warnings occur in the state immediately before error occurrence such as the excessive regeneration or overload.

Error or normality operation cannot be executed by warning when warning is left as it is though servo off is not executed.

The warnings can be automatically released by eliminating the warning cause in the servo amplifier side. However, at that time, the detected servo warnings cannot be automatically released in the QD74MH side.

Eliminate the error cause, and then execute the error reset after confirming the warning release of the servo amplifier side.

If the other warnings occur at servo warning occurrence, the warning code is updated.

(2) Operation warnings (Warning code: 11000 to 11999)

The operation warnings occur when the operation is limited by the wrong positioning setting value at operation start or in operation. The positioning can be executed or continued. However, the intended operation may not execute by the warnings.

Execute the error reset after eliminating the error cause.

If the other warnings occur at operation warning occurrence, the warning code is updated.

11.1.3 Confirming the error and warning definitions

The error detection signal [X1] turns ON" at error occurrence. Simultaneously, the bit corresponding to axis No. of axis that caused the error of the buffer memory "[Md.100](#) Axis error status" turns ON.

The error codes are stored in buffer memory "[Md.6](#) Error code", and the numbers of error details are stored in buffer memory "[Md.7](#) Error detail" of axis that caused the error. Confirm the errors using these information.

The warning detection signal [X2] turns ON" at warning occurrence. Simultaneously, the bit corresponding to axis No. of axis that caused the warning of the buffer memory "[Md.101](#) Axis warning status" turns ON.

The warning codes are stored in buffer memory "[Md.8](#) Warning code" of axis that caused the warning. Confirm the warnings using these information.

11.1.4 Resetting errors

Refet to Section10.20 for the error reset.

11.2 List of Errors

(1) System errors (1 to 999)

Error code	Error detail	Error	Error check	Operation status at error occurrence	Remedy
1	1	Flash ROM error	At power supply ON	Unit READY does not turn ON.	Replace the QH74MH.
2	1	DRAM error			
4	1	High speed SRAM error			
6	1	SSCNETⅢ communication IC send buffer error			
7	1	SSCNETⅢ communication IC receive buffer error			
8	1	Board information error			
9	1	"Hold" is set for QD74MH in "Error time output mode" of the PLC CPU parameter.			Set "Clear" for QD74MH in "Error time output mode" of the parameter.
100	1	CPU error (Instruction code error at power supply ON)		Unit READY turns OFF.	Check the influence of noise.
	4	CPU error (Instruction code error)			Replace the hardware.
	5	CPU error (Watch dog)			
400	1	(1) Setting for "[Pr.300] Servo series" differs from the connecting status of servo amplifier. (2) Communication was cut off by the servo amplifier's power supply OFF.	After PLC READY ON, Always	Forced stop for except axis that caused the error, and unit READY turns OFF.	Execute the power cycle after checking the followings. (1) Setting for "[Pr.300] Servo series" matches to the connecting status and rotary switch of servo amplifier. (2) Power supply status to servo amplifier. (3) SSCNETⅢ cable connection status. (4) Disconnection of SSCNETⅢ cable. (Note): Turn the servo amplifier's power supplies on the communication route ON.
401	1	SSCNETⅢ communication error (CRC error)			Check the followings. (1) SSCNETⅢ cable connection status. (2) Disconnection of SSCNETⅢ cable.
403	1	SSCNETⅢ communication error (Data ID error)			
405	1	Setting for "[Pr.300] Servo series" differs from the connecting type of servo amplifier.	At PLC READY ON		Check the connected servo amplifiers.
406	1	SSCNETⅢ communication error (Connector not connected error)			Check the followings. (1) Power supply status to servo amplifier. (2) SSCNETⅢ cable connection status. (3) Disconnection of SSCNETⅢ cable.
407	1	No response from the servo amplifier and a communication time out occurred.	After PLC READY ON, Always		

System errors (1 to 999) (continued)

Error code	Error detail	Error	Error check	Operation status at error occurrence	Remedy
800	1	Sum check error of parameter stored in the FLASH ROM. (The system's power supply was turned OFF in FLASH ROM write.)	At power supply ON	Unit READY does not turn ON. (Note) FLASH ROM write/parameter initialization function can be used.	Return to the parameters at factory default using the parameter initialization function.
801	1	Data cannot be written to the FLASH ROM.	At FLASH ROM write/parameter initialization function use after the system error occurrence	FLASH ROM write/parameter initialization cannot be executed.	Replace the QH74MH.

(2) Operation errors (1000 to 1899)

Error code	Error detail	Error	Error check	Operation status at error occurrence	Remedy
1010	1	The axis stop command is ON.	<ul style="list-style-type: none"> At positioning start At OPR start 	The operation does not start.	Remove the axis stop.
	2	The axis sudden stop command is ON.	<ul style="list-style-type: none"> At manual operation start 		Remove the axis sudden stop.
1012	1	(1) The forced stop was input in positioning. (2) The operation was started in forced stop.	<ul style="list-style-type: none"> In positioning control or at positioning start In OPR control or at OPR start In manual control or at manual control start 	In start: Forced stop At strat: The operation does not start.	Remove the forced stop.
1013	1	In pausing	<ul style="list-style-type: none"> At positioning start At OPR start At manual operation start 	The operation does not start.	Remove the pausing
1016	1	An error occurred for the interpolation group configured axis.	<ul style="list-style-type: none"> At interpolation control start In interpolation control 	At strat: The operation does not start. In control: ecerelation stop	Remove the error cause for the erroneous axis.
1021	1	The command speed is 4 [PLS/s] or less.	<ul style="list-style-type: none"> At OPR start (OPR speed and creep speed) At positioning start At "positioning data" point change of positioning control At JOG operation start At incremental feed operation start 		Set the command speed to 5 [PLS/s] or more.
1022	4	The positioning data number set in "[Cd.2] Start method" is outside the range.			Set the "[Cd.2] Start method" within the setting range.
	5	All "[Da.0] Operation pattern" for from the positioning data number to final positioning data No.32 set in "[Cd.2] Start method" are set to the continuous positioning or continuous path only.	<ul style="list-style-type: none"> At positioning start At point change 	Set the final positioning data to the independent positioning in "[Da.0] Operation pattern".	
1023	1	(1) The control method was changed in positioning. (1 axis linear ↔ Linear interpolation) (2) The manual control start or OPR start was requested in positioning. (3) The positioning start or OPR start was requested in manual control. (4) The positioning start or manual control start was requested in OPR control.	At positioning data change	Positioning end (Immediate stop in continuous path)	(1) Review the positioning data ("[Da.1] Control system"). (2) Review the start timing of the positioning control. manual control or OPR control.

Operation errors (1000 to 1899) (Continued)

Error code	Error detail	Error	Error check	Operation status at error occurrence	Remedy														
1024	1	(1) The movement direction was reversed in the "positioning data" on the way continuous path. (2) "Stop by the error" is set in "[Pr.23] Target position change overrun processing selection", and the change position was passed by the target position change.	<ul style="list-style-type: none"> At positioning data change of continuous path At target position change 	Deceleration stop	(1) Set "[Da.6] Positioning address/movement amount" not to reverse. (2) Execute the position command in which minimum required deceleration distance to stop was secured.														
1025	1	Setting of "[Da.1] Control system" is wrong.	<ul style="list-style-type: none"> At positioning start At positioning data change 	At strat: The operation does not start.	Set "[Da.1] Control system" correctly.														
	2	Setting of "[Da.0] Operation pattern" is wrong.		In control: Positioning end (Immediate stop in continuous path)	Set "[Da.0] Operation pattern" correctly.														
1026	1	A negative value is set in "[Pr.84] Incremental feedrate".	<ul style="list-style-type: none"> At JOG operation start At incremental feed operation start 	The operation does not start.	Set "0 to 2147483647" in "[Pr.84] Incremental feedrate".														
1037	→	Setting value of parrameters is outside the range. <table border="1" style="margin-left: 20px;"> <thead> <tr> <th>Stored value</th> <th>Parameter No.</th> </tr> </thead> <tbody> <tr> <td>0</td> <td>Pr.0</td> </tr> <tr> <td>1</td> <td>Pr.1</td> </tr> <tr> <td>to</td> <td>to</td> </tr> <tr> <td>99</td> <td>Pr.99</td> </tr> <tr> <td>101</td> <td>Pr.101</td> </tr> <tr> <td>300</td> <td>Pr.300</td> </tr> </tbody> </table>	Stored value	Parameter No.	0	Pr.0	1	Pr.1	to	to	99	Pr.99	101	Pr.101	300	Pr.300	<ul style="list-style-type: none"> At PLC READY ON At parameter change request 	<ul style="list-style-type: none"> Unit READY turns OFF. The operation does not start. 	Set the parameters within the range.
Stored value	Parameter No.																		
0	Pr.0																		
1	Pr.1																		
to	to																		
99	Pr.99																		
101	Pr.101																		
300	Pr.300																		
1040	2	There are 5 or more axes in the group formation of linear interpolation.	At linear interpolation start	The operation does not start.	Set the group formation up to 4 axes.														
	3	The linear interpolation was started with the invalid linear interpolation group number.			Review the setting of linear interpolation group.														
1041	1	There is an axis whose movement amount exceeds the maximum of 999999999 in the group.			Review the setting for movement amount.														
1042	1	The linear interpolation cannot be started because the interpolation axis is in operation.			Start after making sure all axes in the group formation are OFF.														
	2	The linear interpolation cannot be started because an error has set for the interpolation axis.			Remove the error cause on the interpolation axis.														
1090	1	The positioning control or current value change were executed without executing the OPR.	<ul style="list-style-type: none"> At positioning start At current value change 		Execute the OPR. Or, Set "1: Executed" in "[Pr.66] Operation setting for incompleation of OPR".														
1091	1	(1) The zero point has not been passed at limit switch combined type OPR. (2) "1: Used" is set in "[Pr.64] Incremental linear scale setting", and the zero point has not been passed at proximity dog type OPR.	At proximity dog OFF	The sudden stop/OPR is not completed.	Turn the servomotor more than 1 revolution in the + / - direction, and then execute the OPR.														

Operation errors (1000 to 1899) (Continued)

Error code	Error detail	Error	Error check	Operation status at error occurrence	Remedy
1092	1	The proximity dog has been turned OFF before it reached to the cramp speed in the proximity dog type OPR.	At proximity dog OFF	The sudden stop/OPR is not completed.	Lengthen the proximity dog. Or, adjust the OPR speed to stop on the proximity dog.
1094	1	The OPR direction and push direction are opposite in the stopper type OPR.	At stopper type OPR start	The stopper type OPR is not completed.	Set the OPR direction to be the same as the push direction.
1095	1	"Torque limit ([Md.40] Servo status 1: b13)" has not been turned ON at stopper type OPR.			Execute push, and after turning the torque limit on, start OPR.
1096	1	"AL96" has occurred in the servo amplifier, and the OP setting has been failed. Even after 1000[ms] passed at OPR stop, in-position was not achieved.	At OPR stop	The OPR is not completed.	Adjust the servo amplifier so that it stabilizes quickly at OPR stop.
1097	1	Even after 1800[ms] passed at OPR stop, in-position was not achieved.	At OPR stop (Before setting of the distance to Z phase)		(1) Reduce the OPR speed and creep speed. (2) Lengthen the OPR time constant. (3) Broaden the in-position range.
1098	1	When the dog cradle type, proximity dog type or limit switch combined type OPR is used, the movement amount moved to detect the proximity dog signal or zero point exceeded the value set in "[Pr.62] OP search limit".	When the movement amount of oppsite direction against of OPR direction passed the "OP search limit".	Sudden stop	(1) Confirm the input status of proximity dog signal, etc. (2) Confirm the setting value of OP serch limit.
1100	2	When the scale origin signal direction type OPR, or dog cradle type, proximity dog type and limit switch combined type using the incremental linear scale is used, "Need to pass motor Z phase after the power supply is switched on" is not set in "[Pr.397] Function selection C-4".	At OPR start	The OPR does not start.	Set "Need to pass motor Z phase after the power supply is switched on" in "[Pr.397] Function selection C-4".
1101	1	The setting value of software stroke limit exceeded the setting range at OPR start.	At OPR start	The OPR does not start. (The OPR request turns ON.)	Set the value of software stroke limit within the range. (Refer to Section 10.4.2.)
	2	The setting value of software stroke limit exceeded the setting range at first PLC READY ON.	At first PLC READY ON	The OPR request turns ON. (The current value does not restored.)	
1201	1	The backup data for current value restoration is wrong. The OPR has not been executed after setting the absolute position system. The servo parameter "[Pr.314] Rotation direction selection" was changed.	At PLC READY ON	The current value does not restored.	Execute the OPR.
	2	The backup data for current value restoration cannot be saved normally.	At OPR completion	The OPR is not completed.	Replace the QH74MH.

Operation errors (1000 to 1899) (Continued)

Error code	Error detail	Error	Error check	Operation status at error occurrence	Remedy
1500	1	"+" side limit switch ^(Note) is OFF at "+" side positioning start. "+" side limit switch ^(Note) turned OFF in "+" side positioning. (Note): Upper hardware stroke limit switch	At positioning start	At strat: The operation does not start. In control: Sudden stop	Move in the opposite direction by the JOG operation, etc.
	2	"-" side limit switch ^(Note) is OFF at "-" side positioning start. "-" side limit switch ^(Note) turned OFF in "-" side positioning. (Note): Lower hardware stroke limit switch			
1501	1	Positioning outside the software stroke limit was set.	<ul style="list-style-type: none"> At positioning start At manual control start In continuous path 	At strat: The operation does not start. In continuous path: Deceleration stop	Set the movement command within the software stroke limit.
1502	1	The software stroke limit has been reached.	When the deceleration stop position from current value passed the software stroke limit.	Deceleration stop	Move in the opposite direction by the JOG operation, etc.
1504	1	The parameter settings for the software stroke limits is "upper stroke limit \leq lower stroke limit".	At positioning start	The operation does not start.	Set the parameter for the software stroke limit as such "upper stroke limit > lower stroke limit".
1700	1	The axis not to set the servo series was started.	At positioning start	The operation does not start.	Set "[Pr.300] Servo series".
	3	(1) The operation started in servo ready OFF. (2) The servo ready OFF mode was entered in positioning. (Servo amplifier status)	<ul style="list-style-type: none"> At positioning start In positioning 	At strat: The operation does not start. In start: Stop by dynamic brake	(1) Remove the servo alarm. (2) Turn the main circuit ON.
1702	1	(1) Servo is OFF status at positioning start, OPR start or manual operation start. (2) The servo off mode was entered in positioning. (Servo amplifier status)	<ul style="list-style-type: none"> At positioning start In positioning 	At strat: The operation does not start. In start: Stop by dynamic brake	Enter the servo ON.
1703	1	(1) The all axis servo ON command was turned OFF in positioning. (2) "1" is set in "[Cd.30] Each axis servo OFF".	<ul style="list-style-type: none"> At all axis servo OFF (in positioning) At "[Cd.30] Each axis servo OFF" ON (in positioning) 	Sudden stop	
1704	1	The operation started in servo warning (2146, 2149) occurrence.	At positioning start	The operation does not start.	Remove the servo warning.
	2	The servo warning (2146) occurred in operation start.	In positioning	Servo forced stop (Stop by dynamic brake)	

(3) Interface errors (1900 to 1999)

Error code	Error detail	Error	Error check	Operation status at error occurrence	Remedy
1901	1	Data is not written to the flash ROM.	<ul style="list-style-type: none"> • At flash ROM write function use • At parameter initialization function use 	The flash ROM write/parameter initialization is not executed.	Replace the QH74MH.
	2	A sum check error occurred while data is written to the flash ROM.			
1902	1	Over 25 times flash ROM write and parameter initialization were executed from the sequence program in power supply ON.			Review the sequence program not to exceed 25 times flash ROM write and parameter initialization in system's power supply ON.
1903	1	The parameter initialization is requested in PLC READY ON.	At parameter initialization request	The parameter initialization is not executed.	Execute the parameter initialization after PLC READY OFF.
1904	1	The PLC CPU has an error. (Stop error)	Always	In strat: Deceleration stop At start: The operation does not start.	Refer to the "QCPU User's Manual (Hardware Design, Maintenance and Inspection)".

(4) Servo errors (2000 to 2099)

Refer to the "Servo amplifier Instruction Manual" for details of servo error.

Error code	LED indicator of servo amplifier	Error detail	Error name
2010	10	0	Undervoltage
2012	12	0	Memory error 1 (RAM)
2013	13	0	Clock error
2015	15	0	Memory error 2 (EEP-ROM)
2016	16	0	Encoder error 1 (At power on)
2017	17	0	Board error
2019	19	0	Memory error 3 (Flash-ROM)
2020	20	0	Encoder error 2
2024	24	0	Main circuit error
2025	25	0	Absolute position erase
2030	30	0	Regenerative error
2031	31	0	Overspeed
2032	32	0	Overcurrent
2033	33	0	Overvoltage
2034	34	0	Receive error 1
2035	35	0	Command frequency error
2036	36	0	Receive error 2
2037	37	Refer to next page.	Parameter error
2045	45	0	Main circuit device overheat
2046	46	0	Servomotor overheat
2047	47	0	Cooling fan error
2050	50	0	Overload 1
2051	51	0	Overload 2
2052	52	0	Error excessive
2060	1A	0	Motor combination error
2088	888	0	Watchdog
2090	8A	0	USB communication time-out error
2094	8E	0	USB communication error

• Error detail of parameter errors (Error code: 2037)

Error detail	Parameter No.
1	PA01
2	PA02
3	PA03
4	PA04
5	PA05
6	PA06
7	PA07
8	PA08
9	PA09
10	PA10
11	PA11
12	PA12
13	PA13
14	PA14
15	PA15
16	PA16
17	PA17
18	PA18
19	PA19
33	PB01
34	PB02
35	PB03
36	PB04
37	PB05
38	PB06
39	PB07
40	PB08
41	PB09
42	PB10
43	PB11
44	PB12
45	PB13
46	PB14
47	PB15
48	PB16
49	PB17
50	PB18
51	PB19
52	PB20
53	PB21
54	PB22
55	PB23
56	PB24
57	PB25
58	PB26
59	PB27
60	PB28
61	PB29
62	PB30
63	PB31

Error detail	Parameter No.
64	PB32
65	PB33
66	PB34
67	PB35
68	PB36
69	PB37
70	PB38
71	PB39
72	PB40
73	PB41
74	PB42
75	PB43
76	PB44
77	PB45
81	PC01
82	PC02
83	PC03
84	PC04
85	PC05
86	PC06
87	PC07
88	PC08
89	PC09
90	PC10
91	PC11
92	PC12
93	PC13
94	PC14
95	PC15
96	PC16
97	PC17
98	PC18
99	PC19
100	PC20
101	PC21
102	PC22
103	PC23
104	PC24
105	PC25
106	PC26
107	PC27
108	PC28
109	PC29
110	PC30
111	PC31
112	PC32
113	PD01
114	PD02
115	PD03
116	PD04

Error detail	Parameter No.
117	PD05
118	PD06
119	PD07
120	PD08
121	PD09
122	PD10
123	PD11
124	PD12
125	PD13
126	PD14
127	PD15
128	PD16
129	PD17
130	PD18
131	PD19
132	PD20
133	PD21
134	PD22
135	PD23
136	PD24
137	PD25
138	PD26
139	PD27
140	PD28
141	PD29
142	PD30
143	PD31
144	PD32
145	PE01
146	PE02
147	PE03
148	PE04
149	PE05
150	PE06
151	PE07
152	PE08
153	PE09
154	PE10
155	PE11
156	PE12
157	PE13
158	PE14
159	PE15
160	PE16
161	PE17
162	PE18
163	PE19
164	PE20
165	PE21
166	PE22

Error detail	Parameter No.
167	PE23
168	PE24
169	PE25
170	PE26
171	PE27
172	PE28
173	PE29
174	PE30
175	PE31
176	PE32
177	PE33
178	PE34
179	PE35
180	PE36
181	PE37
182	PE38
183	PE39
184	PE40
193	PS01
194	PS02
195	PS03
196	PS04
197	PS05
198	PS06
199	PS07
200	PS08
201	PS09
202	PS10
203	PS11
204	PS12
205	PS13
206	PS14
207	PS15
208	PS16
209	PS17
210	PS18
211	PS19
212	PS20
213	PS21
214	PS22
215	PS23
216	PS24
217	PS25
218	PS26
219	PS27
220	PS28
221	PS29
222	PS30
223	PS31
224	PS32

(5) Servo warning (2100 to 2199)

Refer to the "Servo amplifier Instruction Manual" for details of servo warning.

Warning code	LED indicator of servo amplifier	Warning name
2101	91	Main circuit device overheat warning
2102	92	Battery cable disconnection warning
2106	96	Home position setting warning
2116	9F	Battery warning
2140	E0	Excessive regeneration warning
2141	E1	Overload warning 1
2143	E3	Absolute position counter warning
2144	E4	Parameter warning
2146	E6	Servo forced stop warning
2147	E7	Controller forced stop warning
2148	E8	Cooling fan speed reduction warning
2149	E9	Main circuit off warning
2151	EB	The other axis fault warning
2152	EC	Overload warning 2
2153	ED	Output watt excess warning

(6) Operation warnings (11000 to 11999)

Warning code	Error	Error check	Operation status at warning occurrence	Remedy
10001	The flash ROM write request or parameter initialization request turned ON after the first PLC READY ON.	<ul style="list-style-type: none"> At flash ROM write request At parameter initialization request 	The flash ROM write or parameter initialization is not executed.	Turn the PLC READY ON.
11001	The speed command that exceeds the speed limit value was executed.	<ul style="list-style-type: none"> At positioning start At OPR start At manual control start At speed change request 	The speed is cramped with the speed limit value.	Set the speed within the speed limit value.
11002	The setting of "[Pr.17] Sudden stop deceleration time" is larger than the deceleration time ("[Pr.83] JOG operation deceleration time", "[Pr.59] OPR deceleration time").	<ul style="list-style-type: none"> At axis sudden stop command At pausing command 	The speed is cramped with the deceleration time (JOG operation, OPR).	Shorten the setting of "[Pr.17] Sudden stop deceleration time" than the deceleration time ("[Pr.83] JOG operation deceleration time", "[Pr.59] OPR deceleration time").
11003	The speed command that exceeds the maximum motor speed was executed.	<ul style="list-style-type: none"> At positioning start At OPR start At manual control start At speed change request 	The speed is cramped with the maximum motor speed.	Set the speed within the maximum motor speed.
11005	For the positioning data of continuous path completion, the machine passed a command position and immediately stopped, because the movement amount was short.	In cotinuous path	Immediately stop (If the positioning data	Set the address/movement amount required to execute the deceleration stop.
11006	The machine immediately stopped with the specified address in positioning, because the movement amount required to execute the deceleration stop from the currend speed cannot be secured.	<ul style="list-style-type: none"> At independent positioning At continuous path last point At Incremental feed operation 	continues, the positioning is executed after immediately stop.	Set the positioning data required to execute the deceleration stop.
11011	The speed change request was executed in the following cases. <ul style="list-style-type: none"> In operation stop In deceleration by stop command, sudden stop command or error occurrence In OPR In current value change In pausing 	At speed change request	The speed change is not executed.	Change the speed when the speed change can be executed.
11012	The acceleration speed change request was executed in the following cases. <ul style="list-style-type: none"> In operation stop In deceleration In OPR In current value change In pausing 	At acceleration time change request	The acceleration time change is not executed.	Change the acceleration time when the speed change can be executed.
11013	The deceleration speed change request was executed in the following cases. <ul style="list-style-type: none"> In operation stop In deceleration In OPR In current value change In pausing 	At deceleration time change request	The deceleration time change is not executed.	Change the deceleration time when the speed change can be executed.

Operation warnings (11000 to 11999) (continued)

Warning code	Error	Error check	Operation status at warning occurrence	Remedy
11014	The target position change request was executed in the following cases. <ul style="list-style-type: none">• In operation stop• In deceleration by stop command, sudden stop command or error• In JOG operation• In OPR• In linear interpolation• In current value change• In pausing	At target position change request	The target position change is not executed.	Change the target position when the speed change can be executed.

MEMO

APPENDICES

Appendix 1 External Dimension Drawing

(1) QD74MH8

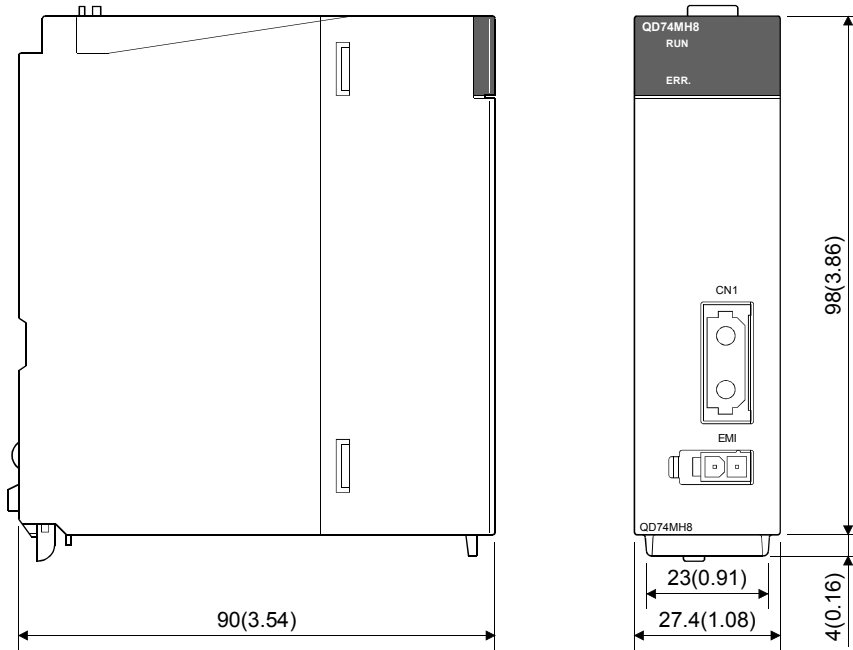

(2) QD74MH16

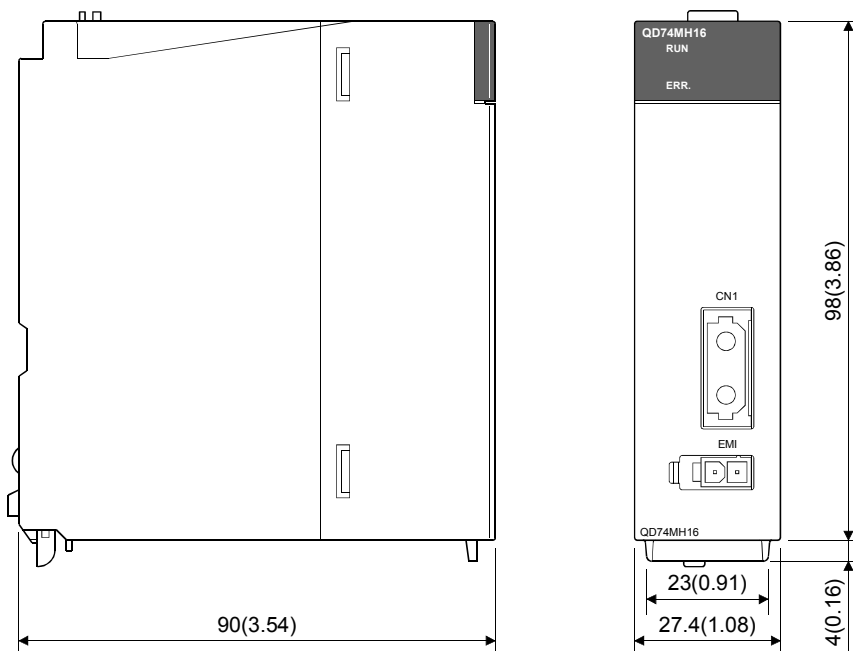

Appendix 2 Sample Program

Appendix 2.1 Sequence program

Creation procedure for the standard sequence program of QD74MH is shown below.

⚠ CAUTION

- The sequence program of this appendix is used to make operate the servo motor for 1 axis. When diverting the programs examples introduced in this manual to the actual system, fully verify that there are no problems in the controllability of the target system. And, add the interlock condition if required in the target system.

- (1) JOG operation, OPR operation positioning control and continuous path control can be executed by setting the data to the buffer memory in QD74MH. The monitor data of the current value and error codes, etc. can be referred by reading the data of buffer memory. Data is transferred via the buffer memory between the PLC CPU and QD74MH in the figure below. Use the GX Developer to create the sequence program and debugging.

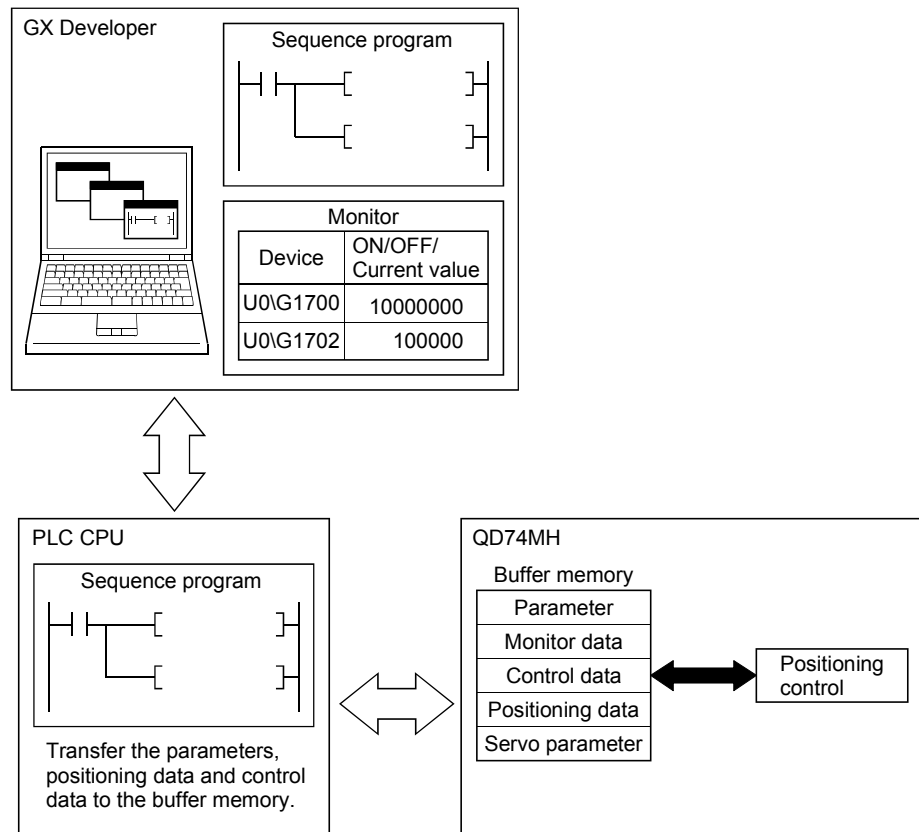

(2) System configuration

The configuration figure for 1 axis absolute position system of 1 axis assumed by the sequence program is shown below.

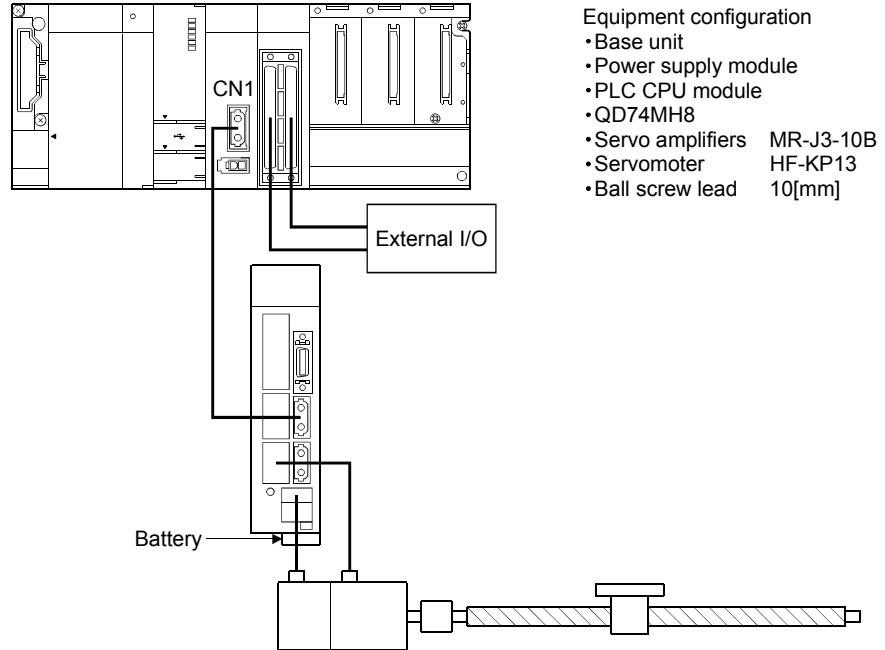

- Equipment configuration
- Base unit
 - Power supply module
 - PLC CPU module
 - QD74MH8
 - Servo amplifiers MR-J3-10B
 - Servomotor HF-KP13
 - Ball screw lead 10[mm]

(a) Setting for the electronics gear

- Command unit : 0.1[μm]
- Ball screw lead : Pb = 10[mm] = 100000[×0.1μm]
- Encoder resolution : Pt = 262144[PLS/rev]
- Gear ratio : n = 1/1

$$\frac{AP}{AL} = \frac{Pt}{\angle S} = \frac{Pt}{n \times Pb} = \frac{262144}{\frac{1}{1} \times 10000} = \frac{8192}{3125}$$

- "Pr.0 Electronic gear numerator" = 8192,
- "Pr.2 Electronic gear denominator" = 3125

(b) Unit of the positioning address and command speed

The command unit of the QD74MH is PLS only. When an electronic gear is set, programming in units of [mm] is possible.

When the command unit is 0.1[μm], "Da.6 Positioning address/movement amount" and "Da.4 Command speed" can also be set using units of 0.1[μm].

POINT

When the command unit is 0.1[μm] = 1[PLS], the ball screw lead of 10[mm] is 100000 [PLS]. When the electronic gear numerator (AP) and denominator (AL) are calculated by this value, the command unit can be either PLS or 0.1[μm].

(c) Setting for the speed limit value

$$\text{Speed limit value[PLS/s]} = \frac{(\text{Motor's maximum velocity[r/min]} \times \text{Gear ratio}(n)) \times \text{Ball screw lead}}{60[\text{s}]}$$

Example) When the speed limit is set to match the motor's maximum velocity (6000[r/min])

$$\text{Speed limit value} = \frac{\left(6000 \times \frac{1}{1}\right) \times 10}{60} = 1000[\text{mm/s}]$$

When the command unit is 0.1[μm],

$$1000[\text{mm/s}] = 10000000[\text{PLS/s}] = 10 \times 10^6 [\text{PLS/s}]$$

Therefore, set 10 so that the "Pr.10 Speed limit value" is [$\times 10^6$ PLS/s] unit.

Appendix 2.2 Creating the program

This section describes the operation program actually used for positioning control. Add the monitor program according to the system to monitor the control.

(1) Program configuration

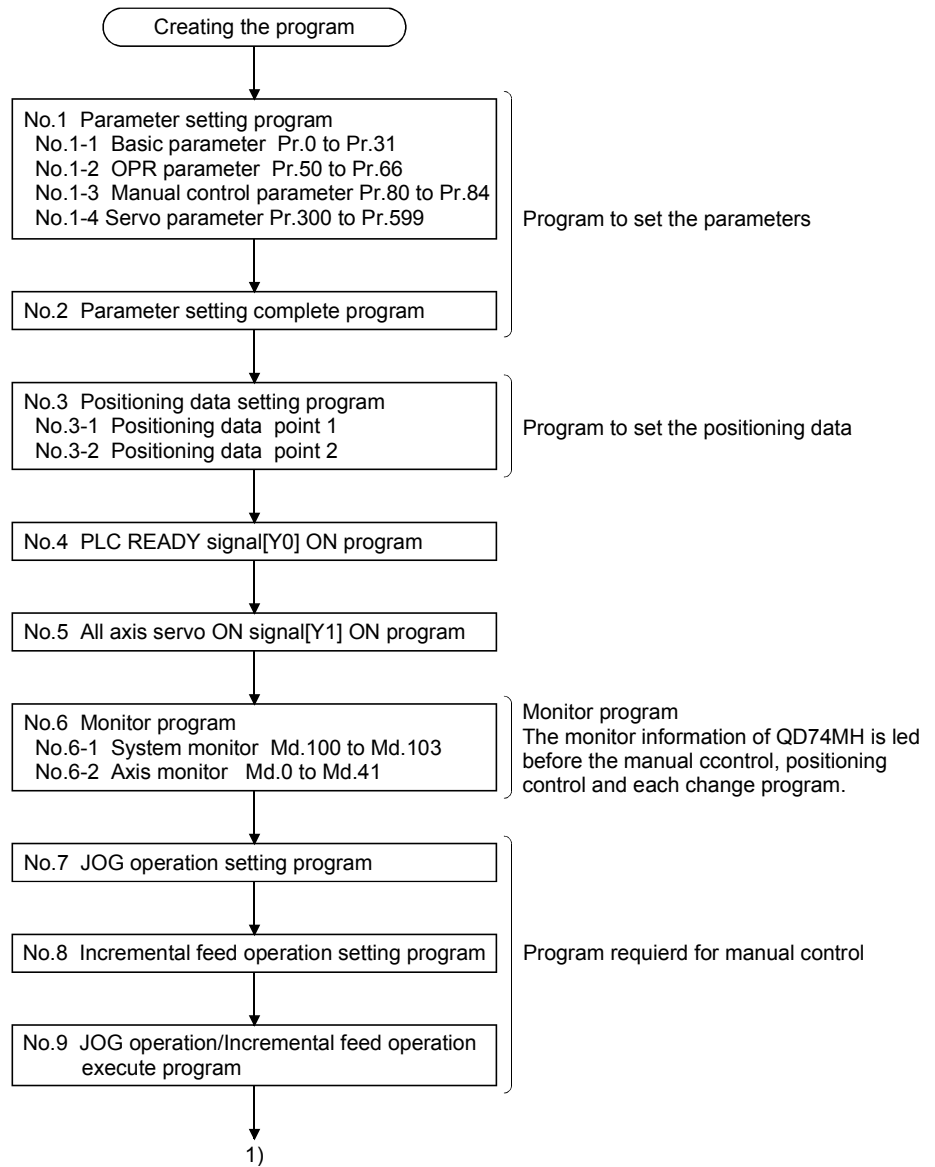

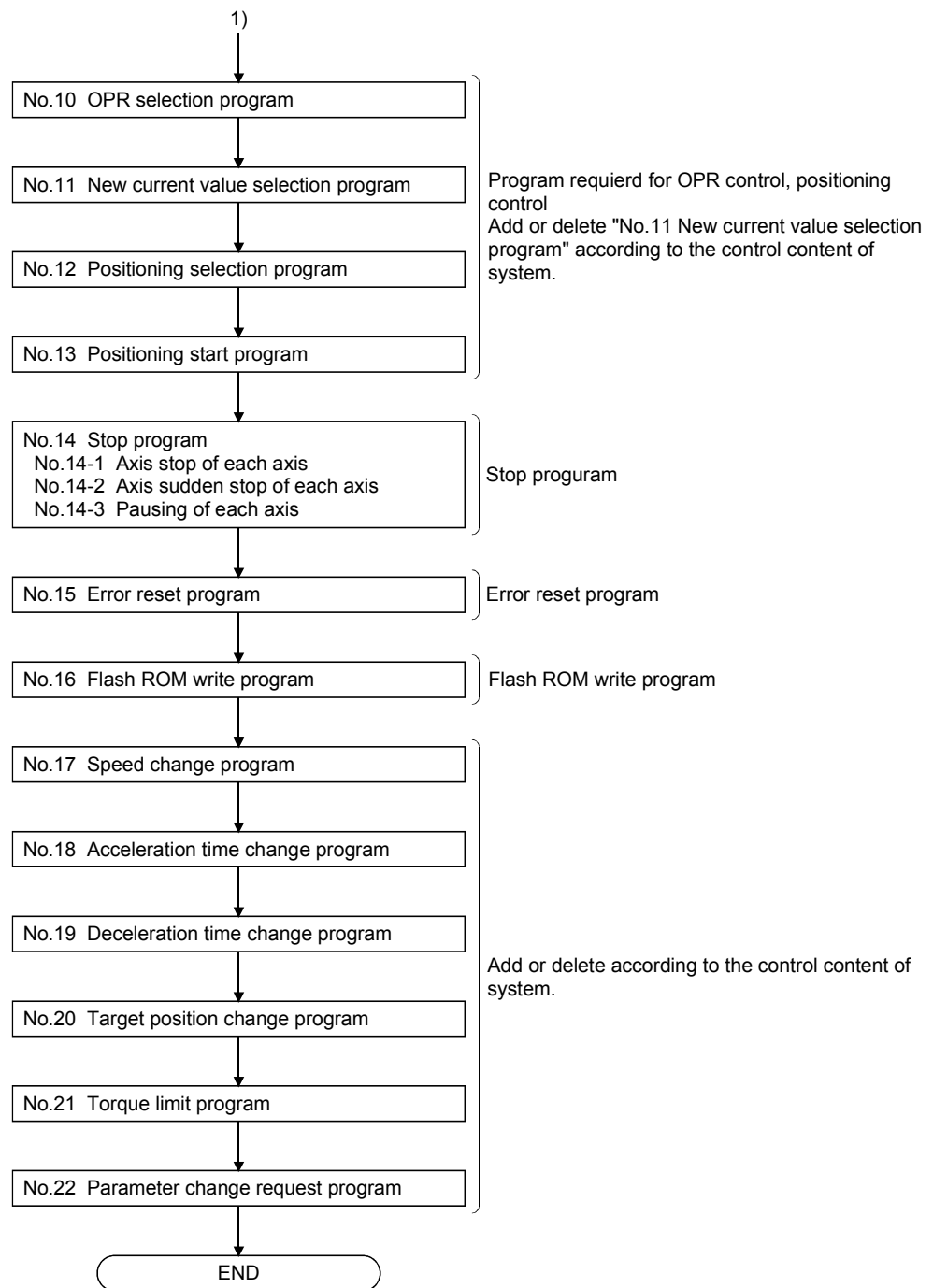

(2) Device list

The devices used by the sequence program that has been described to this appendix are allocated as follows.

The I/O number is a number when the QD74MH is installed in the first slot of the main base unit. Change them to I/O number at installed position if the QD74MH is installed in except the first slot of the main base unit.

Change the external input/output, internal relay and data register according to the system used.

(a) Input/output, external input, external output, internal relay

Type	Device No.	Signal name
Input	X0	Unit READY
	X1	Error detection
	X2	Warning detection
	X3	Synchronization flag
	X10	Axis 1 BUSY
Output	Y0	PLC READY
	Y1	All axis servo ON
	Y2	Forced stop input
	Y10	Axis 1 Positioning start
External input	X20	Positioning start
	X21	Axis stop
	X22	Pausing
	X23	Axis sudden stop
	X24	All axis servo ON request
	X25	PLC READY ON request
	X26	Error reset
	X27	Parameter change request
	X28	Flash ROM write
	X29	Acceleration time change request
	X2A	Deceleration time change request
	X2B	Speed change request
	X2C	Incremental feed
	X2E	Forward rotation JOG/Incremental feed
	X2F	Reverse rotation JOG/Incremental feed
	X30	Torque limit value change request
	X31	Target position change request
	X33	Positioning selection
	X34	Current value change selection
	X35	OPR selection

Type	Device No.	Signal name
Internal relay	M0	Parameter setting flag
	M1	Parameter setting complete flag
	M2	Position data setting flag
	M4	Flash ROM write memo
	M5	Deceleration time change request memo
	M7	In JOG/incremental feed operation memo
	M8	Speed change request memo
	M9	Acceleration time change request memo
	M10	Axis 1 Error detection signal
	M29	Target position change request memo
	M30	Axis 1 Warning detection signal
	M47	Axis 1 Speed change request memo
	M63	Positioning start pulse
	M64	Axis 1 Positioning start
	M80	Axis 1 Acceleration time change request memo
	M96	Axis 1 Deceleration time change request memo
	M112	Axis 1 Target position change request memo
	M128	Axis 1 In JOG/incremental feed operation
	M160	Axis 1 Positioning complete
	M161	Axis 1 Command in-position
	M162	Axis 1 Pausing
M163	Axis 1 Operation complete	
M168	Axis 1 Speed change READY	
M169	Axis 1 Acceleration time change READY	
M170	Axis 1 Deceleration time change READY	
M171	Axis 1 Target position change READY	

(b) Data register

Type	Device No.	Signal name		
Data register	D24	Incremental feedrate		
	D31	Axis 1 Start data No./type		
	D100	Md.0	Axis 1 Current feed value	Low-order 16 bits
	D101			High-order 16 bits
	D102	Md.2	Axis 1 Feedrate	Low-order 16 bits
	D103			High-order 16 bits
	D104	Md.4	Axis 1 External input signal	
	D105	Md.5	Axis 1 Positioning data No. being executed	
	D106	Md.6	Axis 1 Error code	
	D107	Md.7	Axis 1 Error detail	
	D108	Md.8	Axis 1 Warning code	
	D109	Md.9	Axis 1 Status 1	
	D110	Md.10	Axis 1 Status 2	
	D126	Md.26	Axis 1 Real current value	Low-order 16 bits
	D127			High-order 16 bits
	D128	Md.28	Axis 1 Deviation counter value	Low-order 16 bits
	D129			High-order 16 bits
	D131	Md.31	Axis 1 Motor current value	
	D132	Md.32	Axis 1 Motor rotation speed	
	D134	Md.34	Axis 1 Regenerative load ratio	
	D135	Md.35	Axis 1 Effective load torque ratio	
	D136	Md.36	Axis 1 Servo status 2	
	D140	Md.40	Axis 1 Servo status 1	
	D141	Md.41	Axis 1 Servo status 2	

(Note): Transmit the current feed value, feedrate and real current value, etc. using the 32 bit transmission instruction.

(3) Parameters and positioning data

Types of parameters include: Basic parameters, OPR parameters, Manual control parameters and Servo parameters.

The parameters to be changed are shown below.

Add and change the parameters and positioning data according to the system.

Table 2.1 Parameters for 1 axis

Type	Symbol	Item	Word	Value for 1-axis	Address	Remark
Basic	Pr.0	Electronic gear numerator (AP)	2	8192	U0\G0+100n	Set these parameters according to the system.
	Pr.2	Electronic gear denominator (AL)	2	3125	U0\G2+100n	
	Pr.4	Software stroke limit upper limit value	2	819100000	U0\G4+100n	Set these parameters according to movement range for the system.
	Pr.6	Software stroke limit lower limit value	2	-819100000	U0\G6+100n	
	Pr.10	Speed limit value	2	10	U0\G10+100n	
	Pr.25	Interpolation group	1	1	U0\G25+100n	
	Pr.26	Linear interpolation speed limit value	2	10	U0\G26+100n	
OP	Pr.31	External input signal logic selection	1	H0	U0\G31+100n	H0 : Negative logic H11: Positive logic
	Pr.50	OPR method	1	2	U0\G50+100n	Data set type
Manual	Pr.52	OP address	2	0	U0\G52+100n	
	Pr.80	JOG speed	2	2500000	U0\G80+100n	
Servo	Pr.84	Incremental feedrate	2	0	U0\G84+100n	Set "0" at JOP operation.
	Pr.300	Servo series	1	1	U0\G10300+100n	MR-J3-B
	Pr.303	PA03 Absolute position detection system	1	1	U0\G10303+100n	Absolute position system
	Pr.304	PA04 Function selection A-1	1	0	U0\G10304+100n	H0 : Forced stop: Valid H100: Forced stop: Invalid
	Pr.308	PA08 Auto tuning mode	1	1	U0\G10308+100n	
	Pr.309	PA09 Auto tuning response	1	12	U0\G10309+100n	
	Pr.314	PA14 Rotation direction selection	1	0	U0\G10314+100n	0: CCW direction 1: CW direction

Table 2.2 Positioning data for 1-axis

Type	Symbol	Item	Word	Value for 1-axis	Address	Remark
Point 1	Da.0	Operation pattern	1	1	U0\G5100+10n	Continuous positioning
	Da.1	Control system	1	0	U0\G5101+10n	ABS linear 1
	Da.2	Acceleration time	1	1000	U0\G5102+10n	1000[ms]
	Da.3	Deceleration time	1	1000	U0\G5103+10n	1000[ms]
	Da.4	Command speed	2	1000000	U0\G5104+10n	100[mm/s]
	Da.6	Positioning address/movement amount	2	5000000	U0\G5106+10n	Move to address 50[mm]
	Da.8	Dwell time	1	0	U0\G5108+10n	0[s]
Point 2	Da.0	Operation pattern	1	0	U0\G5110+10n	Independent positioning
	Da.1	Control system	1	0	U0\G5111+10n	ABS linear 1
	Da.2	Acceleration time	1	100	U0\G5112+10n	1000[ms]
	Da.3	Deceleration time	1	100	U0\G5113+10n	1000[ms]
	Da.4	Command speed	2	2500000	U0\G5114+10n	250[mm/s]
	Da.6	Positioning address/movement amount	2	0	U0\G5116+10n	Move to address 0[mm]
	Da.8	Dwell time	1	0	U0\G5118+10n	0[s]

Appendix 2.3 Debugging

(1) Debugging

GX Developer is used to create the sequence program and debug in QD74MH.

First, create the device comment to create the sequence program.

The device comment is displayed by registering the devices to the entry data monitor. It becomes easy to debug by the device and comment being displayed simultaneously.

(2) Flash ROM write

Execute the flash ROM write after completion of the adjustment for servo amplifier. The following buffer memories of servo parameter are changed when the auto tuning mode is valid.

- [Pr.338](#) Ratio of load inertia moment to servo motor inertia moment
- [Pr.339](#) Model loop gain
- [Pr.340](#) Position loop gain
- [Pr.341](#) Speed loop gain
- [Pr.342](#) Speed integral compensation

The buffer memory data returns to former data by the system power supply OFF. Set "1" in [Cd.100](#) Flash ROM write request before the system power supply OFF.

Appendix 2.4 Positioning program example

*
 * No.1 Parameter setting program
 *
 * Basic parameter, OPR parameter, Manual control parameter
 * Servo parameter, System parameter
 * Write the parameters to the buffer memory*
 *
 *SM403 is added so that M0 may turn ON/OFF by the PLC RUN/STOP.

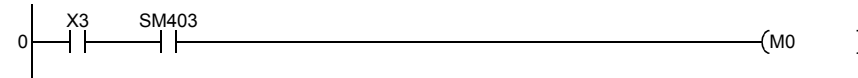

* No.1-1 Basic parameter Pr.0 to Pr.31
 * Axis 1 setting example

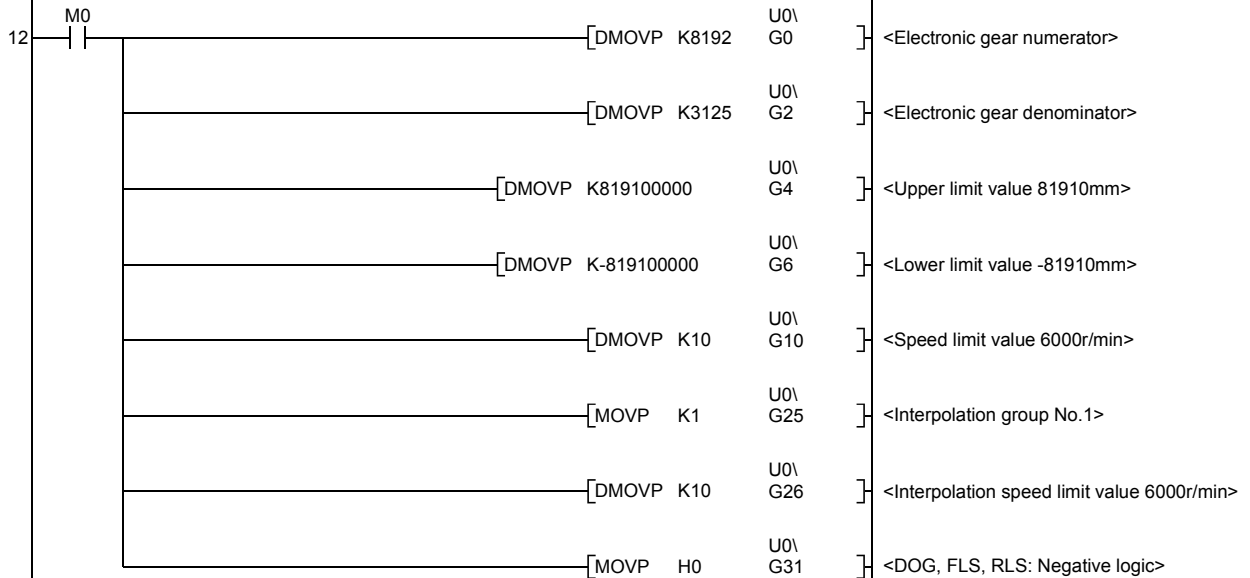

* No.1-2 OPR parameter Pr.50 to Pr.66
 * Axis 1 setting example

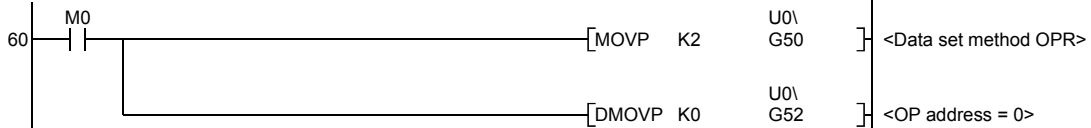

* No.1-3 Manual control parameter Pr.80 to Pr.84
 * Axis 1 setting example

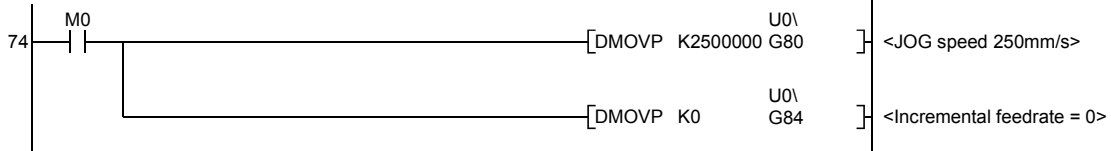

* No.1-4 Servo parameter Pr.300 to Pr.599
 * Axis 1 PA02 to PA15 setting example

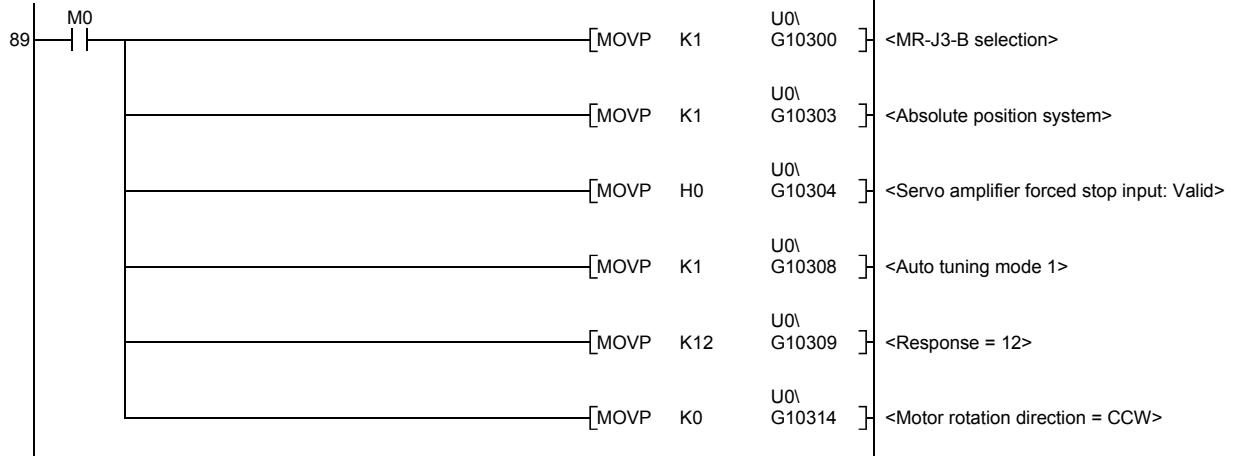

*
 * No.2 Parameter setting complete program
 *
 * Set the basic parameter, OPR parameter, manual control parameter and system parameter
 * ahead of this step.

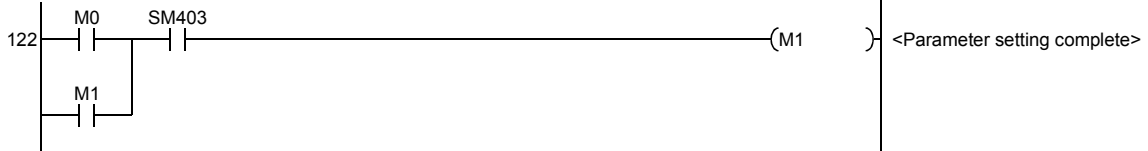

*
 * No.3 Positioning data setting program
 * Positioning data setting flag ON

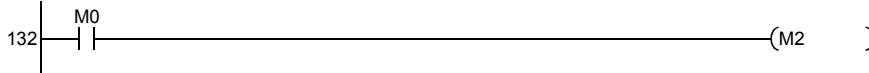

*
 * No.3-1 Positioning data point 1

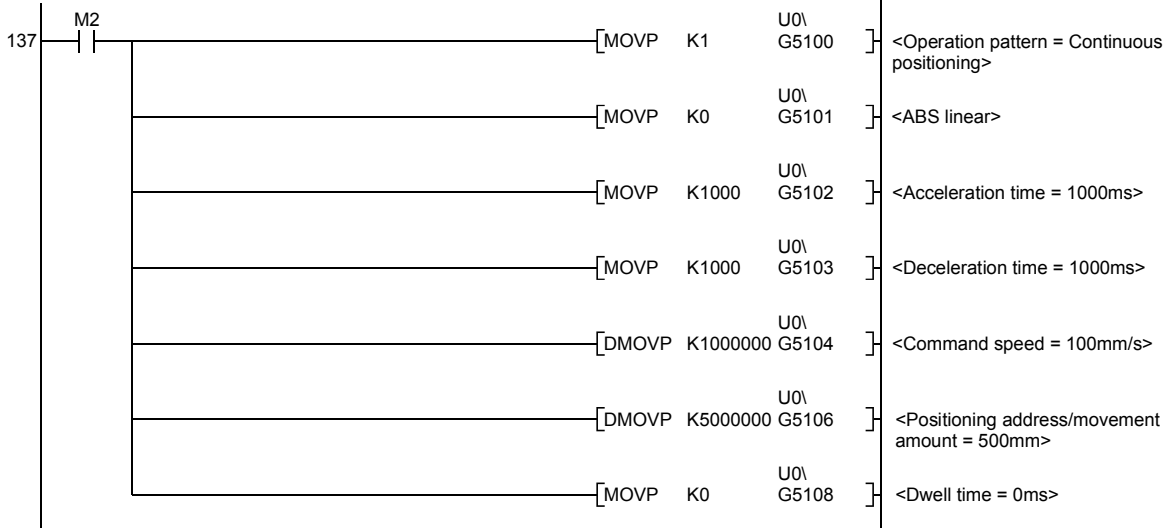

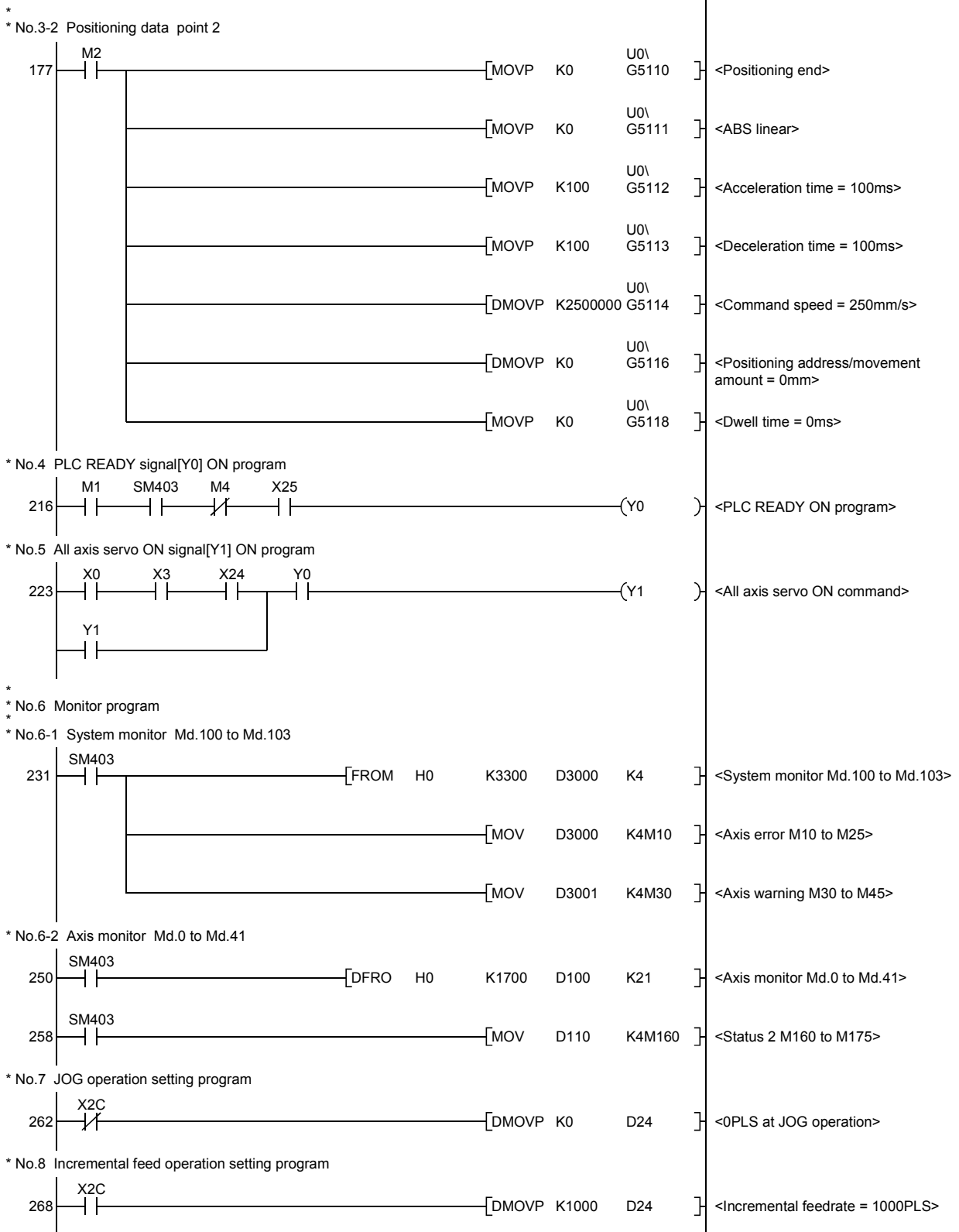

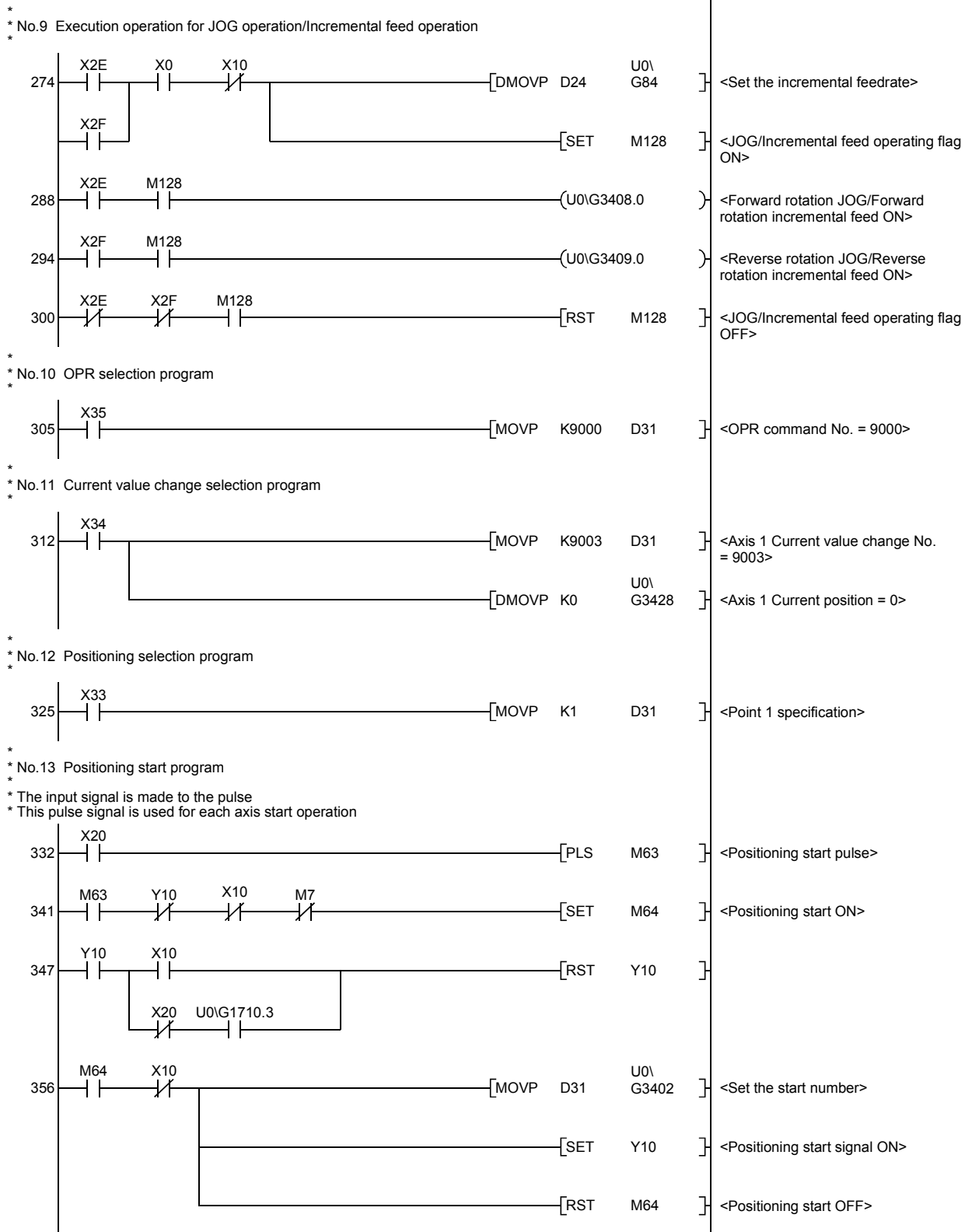

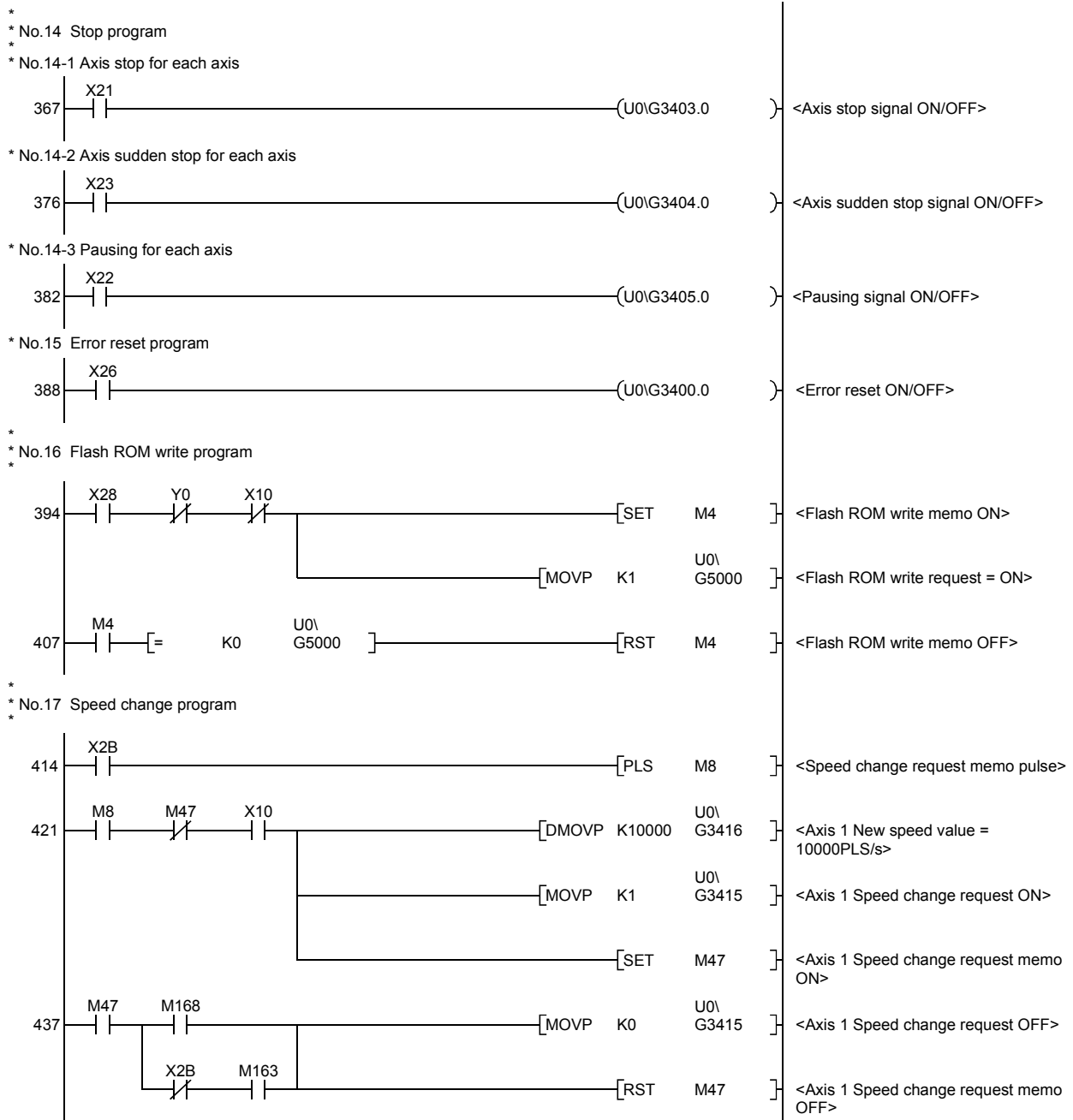

* No.18 Acceleration time change program

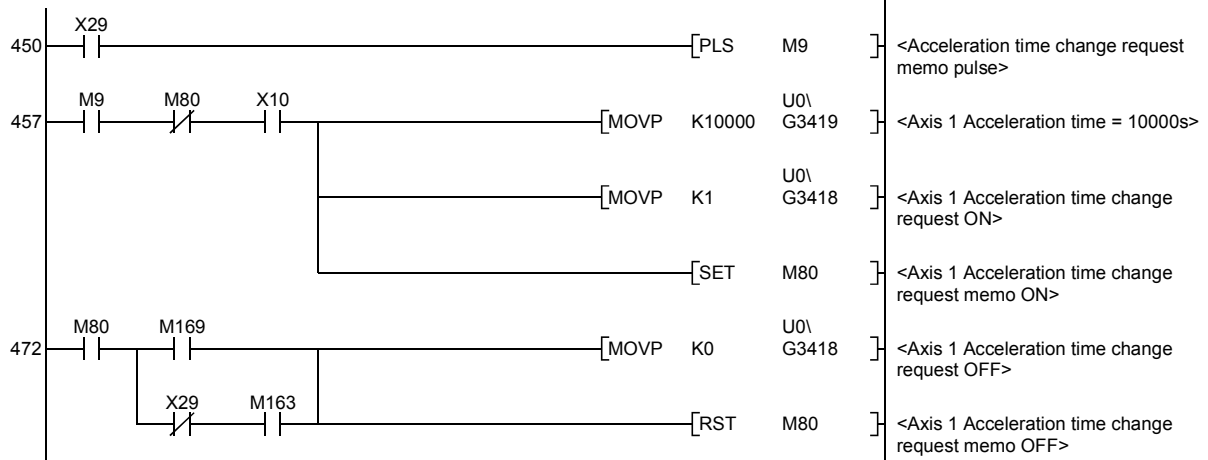

* No.19 Deceleration time change program

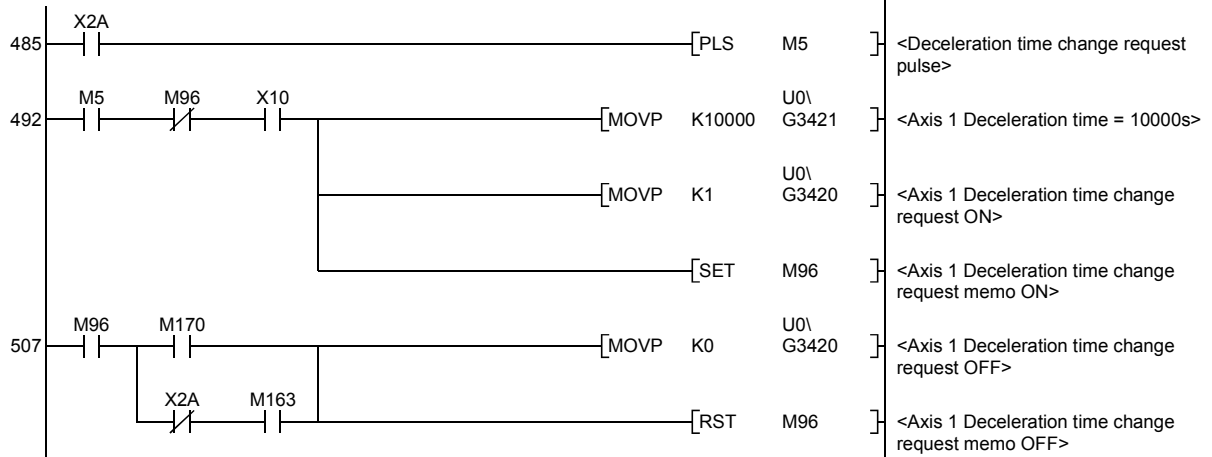

* No.20 Target position change program

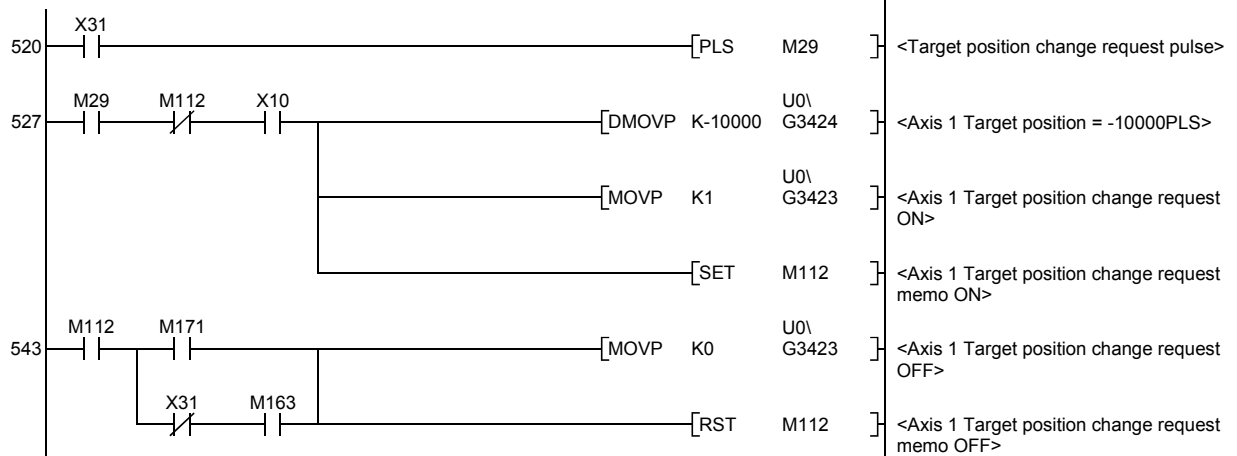

*
* No.21 Torque limit program
*

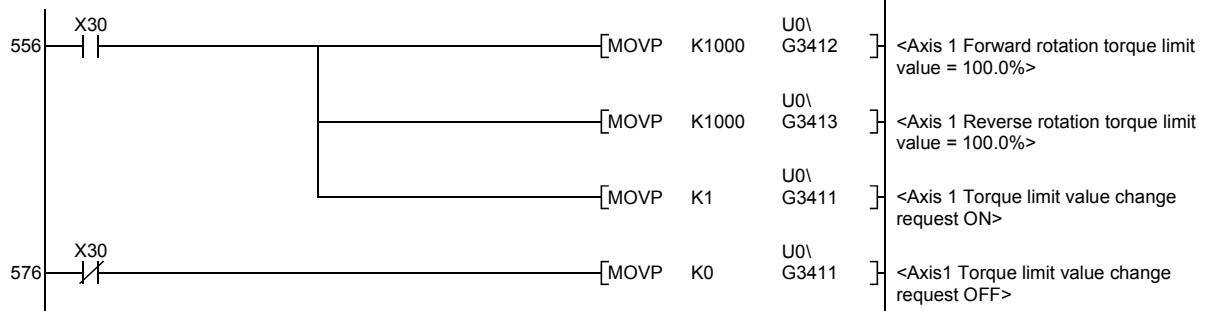

*
* No.22 Parameter change request program
*

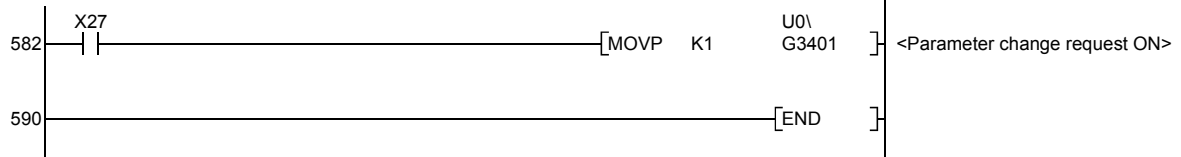

Appendix 3 List of Buffer Memory Address

Appendix 3.1 Parameter area

Symbol	Item	Buffer memory address						
		Axis 1	Axis 2	Axis 3	Axis 4	Axis 5	Axis 6	
Pr.0	Electronic gear numerator (AP)	0	100	200	300	400	500	
		1	101	201	301	401	501	
Pr.2	Electronic gear denominator (AL)	2	102	202	302	402	502	
		3	103	203	303	403	503	
Pr.4	Software stroke limit upper limit value	4	104	204	304	404	504	
		5	105	205	305	405	505	
Pr.6	Software stroke limit lower limit value	6	106	206	306	406	506	
		7	107	207	307	407	507	
Pr.8	Backlash compensation amount	8	108	208	308	408	508	
Pr.10	Speed limit value	10	110	210	310	410	510	
		11	111	211	311	411	511	
Pr.15	Acceleration/deceleration method	15	115	215	315	415	515	
Pr.16	S-curve acceleration/deceleration time constant	16	116	216	316	416	516	
Pr.17	Sudden stop deceleration time	17	117	217	317	417	517	
Pr.20	Command in-position range	20	120	220	320	420	520	
		21	121	221	321	421	521	
Pr.23	Target position change overrun processing selection	23	123	223	323	423	523	
Pr.25	Interpolation group	25	125	225	325	425	525	
Pr.26	Linear interpolation speed limit value	26	126	226	326	426	526	
		27	127	227	327	427	527	
Pr.31	External input signal logic selection	31	131	231	331	431	531	
Pr.50	OPR method	50	150	250	350	450	550	
Pr.51	OPR direction	51	151	251	351	451	551	
Pr.52	OP address	52	152	252	352	452	552	
		53	153	253	353	453	553	
Pr.54	OPR speed	54	154	254	354	454	554	
		55	155	255	355	455	555	
Pr.56	Creep speed	56	156	256	356	456	556	
Pr.58	OPR acceleration time	58	158	258	358	458	558	
Pr.59	OPR deceleration time	59	159	259	359	459	559	
Pr.60	OP shift amount	60	160	260	360	460	560	
		61	161	261	361	461	561	
Pr.62	OP search limit	62	162	262	362	462	562	
		63	163	263	363	463	563	
Pr.66	Operation setting for incompleteness of OPR	66	166	266	366	466	566	
Pr.80	JOG speed	80	180	280	380	480	580	
		81	181	281	381	481	581	
Pr.82	JOG operation acceleration time	82	182	282	382	482	582	
Pr.83	JOG operation deceleration time	83	183	283	383	483	583	
Pr.84	Incremental feedrate	84	184	284	384	484	584	
		85	185	285	385	485	585	
Pr.101	External forced stop selection	1601						

Buffer memory address											Memory area
Axis 7	Axis 8	Axis 9	Axis 10	Axis 11	Axis 12	Axis 13	Axis 14	Axis 15	Axis 16		
600	700	800	900	1000	1100	1200	1300	1400	1500	Basic parameters	
601	701	801	901	1001	1101	1201	1301	1401	1501		
602	702	802	902	1002	1102	1202	1302	1402	1502		
603	703	803	903	1003	1103	1203	1303	1403	1503		
604	704	804	904	1004	1104	1204	1304	1404	1504		
605	705	805	905	1005	1105	1205	1305	1405	1505		
606	706	806	906	1006	1106	1206	1306	1406	1506		
607	707	807	907	1007	1107	1207	1307	1407	1507		
608	708	808	908	1008	1108	1208	1308	1408	1508		
610	710	810	910	1010	1110	1210	1310	1410	1510		
611	711	811	911	1011	1111	1211	1311	1411	1511		
615	715	815	915	1015	1115	1215	1315	1415	1515		
616	716	816	916	1016	1116	1216	1316	1416	1516		
617	717	817	917	1017	1117	1217	1317	1417	1517		
620	720	820	920	1020	1120	1220	1320	1420	1520		
621	721	821	921	1021	1121	1221	1321	1421	1521		
623	723	823	923	1023	1123	1223	1323	1423	1523		
625	725	825	925	1025	1125	1225	1325	1425	1525		
626	726	826	926	1026	1126	1226	1326	1426	1526		
627	727	827	927	1027	1127	1227	1327	1427	1527		
631	731	831	931	1031	1131	1231	1331	1431	1531		
650	750	850	950	1050	1150	1250	1350	1450	1550		
651	751	851	951	1051	1151	1251	1351	1451	1551		
652	752	852	952	1052	1152	1252	1352	1452	1552		
653	753	853	953	1053	1153	1253	1353	1453	1553		
654	754	854	954	1054	1154	1254	1354	1454	1554		
655	755	855	955	1055	1155	1255	1355	1455	1555		
656	756	856	956	1056	1156	1256	1356	1456	1556		
658	758	858	958	1058	1158	1258	1358	1458	1558		
659	759	859	959	1059	1159	1259	1359	1459	1559		
660	760	860	960	1060	1160	1260	1360	1460	1560		
661	761	861	961	1061	1161	1261	1361	1461	1561		
662	762	862	962	1062	1162	1262	1362	1462	1562		
663	763	863	963	1063	1163	1263	1363	1463	1563		
666	766	866	966	1066	1166	1266	1366	1466	1566		
680	780	880	980	1080	1180	1280	1380	1480	1580		
681	781	881	981	1081	1181	1281	1381	1481	1581		
682	782	882	982	1082	1182	1282	1382	1482	1582		
683	783	883	983	1083	1183	1283	1383	1483	1583		
684	784	884	984	1084	1184	1284	1384	1484	1584		
685	785	885	985	1085	1185	1285	1385	1485	1585		
1601											System parameters

Parameter area

Basic parameters

OPR parameters

Manual control parameter

Appendix 3.2 Monitor data area

Symbol	Item	Buffer memory address						
		Axis 1	Axis 2	Axis 3	Axis 4	Axis 5	Axis 6	
Md.0	Current feed value	1700	1800	1900	2000	2100	2200	
		1701	1801	1901	2001	2101	2201	
Md.2	Feedrate	1702	1802	1902	2002	2102	2202	
		1703	1803	1903	2003	2103	2203	
Md.4	External input signal	1704	1804	1904	2004	2104	2204	
Md.5	Positioning data No. being executed	1705	1805	1905	2005	2105	2205	
Md.6	Error code	1706	1806	1906	2006	2106	2206	
Md.7	Error detail	1707	1807	1907	2007	2107	2207	
Md.8	Warning code	1708	1808	1908	2008	2108	2208	
Md.9	Status 1	1709	1809	1909	2009	2109	2209	
Md.10	Status 2	1710	1810	1910	2010	2110	2210	
Md.26	Real current value	1726	1826	1926	2026	2126	2226	
		1727	1827	1927	2027	2127	2227	
Md.28	Deviation counter value	1728	1828	1928	2028	2128	2228	
		1729	1829	1929	2029	2129	2229	
Md.31	Motor current value	1731	1831	1931	2031	2131	2231	
Md.32	Motor rotation speed	1732	1832	1932	2032	2132	2232	
		1733	1833	1933	2033	2133	2233	
Md.34	Regenerative load ratio	1734	1834	1934	2034	2134	2234	
Md.35	Effective load torque ratio	1735	1835	1935	2035	2135	2235	
Md.36	Peak torque ratio	1736	1836	1936	2036	2136	2236	
Md.40	Servo status 1	1740	1840	1940	2040	2140	2240	
Md.41	Servo status 2	1741	1841	1941	2041	2141	2241	
Md.100	Axis error status	3300						
Md.101	Axis warning status	3301						
Md.102	Number of write accesses to flash ROM	3302						
Md.103	Forced stop input status	3303						

Buffer memory address											Memory area	
Axis 7	Axis 8	Axis 9	Axis 10	Axis 11	Axis 12	Axis 13	Axis 14	Axis 15	Axis 16			
2300	2400	2500	2600	2700	2800	2900	3000	3100	3200	Axis monitor data	Monitor data area	
2301	2401	2501	2601	2701	2801	2901	3001	3101	3201			
2302	2402	2502	2602	2702	2802	2902	3002	3102	3202			
2303	2403	2503	2603	2703	2803	2903	3003	3103	3203			
2304	2404	2504	2604	2704	2804	2904	3004	3104	3204			
2305	2405	2505	2605	2705	2805	2905	3005	3105	3205			
2306	2406	2506	2606	2706	2806	2906	3006	3106	3206			
2307	2407	2507	2607	2707	2807	2907	3007	3107	3207			
2308	2408	2508	2608	2708	2808	2908	3008	3108	3208			
2309	2409	2509	2609	2709	2809	2909	3009	3109	3209			
2310	2410	2510	2610	2710	2810	2910	3010	3110	3210			
2326	2426	2526	2626	2726	2826	2926	3026	3126	3226			
2327	2427	2527	2627	2727	2827	2927	3027	3127	3227			
2328	2428	2528	2628	2728	2828	2928	3028	3128	3228			
2329	2429	2529	2629	2729	2829	2929	3029	3129	3229			
2331	2431	2531	2631	2731	2831	2931	3031	3131	3231			
2332	2432	2532	2632	2732	2832	2932	3032	3132	3232			
2333	2433	2533	2633	2733	2833	2933	3033	3133	3233			
2334	2434	2534	2634	2734	2834	2934	3034	3134	3234			
2335	2435	2535	2635	2735	2835	2935	3035	3135	3235			
2336	2436	2536	2636	2736	2836	2936	3036	3136	3236			
2340	2440	2540	2640	2740	2840	2940	3040	3140	3240			
2341	2441	2541	2641	2741	2841	2941	3041	3141	3241			
	3300										System monitor data	
	3301											
	3302											
	3303											

Appendix 3.3 Control data area

Symbol	Item	Buffer memory address						
		Axis 1	Axis 2	Axis 3	Axis 4	Axis 5	Axis 6	
Cd.0	Axis error reset	3400	3500	3600	3700	3800	3900	
Cd.1	Parameter change request	3401	3501	3601	3701	3801	3901	
Cd.2	Start method	3402	3502	3602	3702	3802	3902	
Cd.3	Axis stop	3403	3503	3603	3703	3803	3903	
Cd.4	Axis sudden stop	3404	3504	3604	3704	3804	3904	
Cd.5	Pausing	3405	3505	3605	3705	3805	3905	
Cd.8	Forward rotation JOG start	3408	3508	3608	3708	3808	3908	
Cd.9	Reverse rotation JOG start	3409	3509	3609	3709	3809	3909	
Cd.11	Torque limit request	3411	3511	3611	3711	3811	3911	
Cd.12	Forward rotation torque limit value	3412	3512	3612	3712	3812	3912	
Cd.13	Reverse rotation torque limit value	3413	3513	3613	3713	3813	3913	
Cd.15	Speed change request	3415	3515	3615	3715	3815	3915	
Cd.16	New speed value	3416	3516	3616	3716	3816	3916	
		3417	3517	3617	3717	3817	3917	
Cd.18	Acceleration time change request	3418	3518	3618	3718	3818	3918	
Cd.19	New acceleration time value	3419	3519	3619	3719	3819	3919	
Cd.20	Deceleration time change request	3420	3520	3620	3720	3820	3920	
Cd.21	New deceleration time value	3421	3521	3621	3721	3821	3921	
Cd.23	Target position change request	3423	3523	3623	3723	3823	3923	
Cd.24	New target position change value	3424	3524	3624	3724	3824	3924	
		3425	3525	3625	3725	3825	3925	
Cd.28	New current value	3428	3528	3628	3728	3828	3928	
		3429	3529	3629	3729	3829	3929	
Cd.30	Each axis servo OFF	3430	3530	3630	3730	3830	3930	
Cd.46	Gain changing request	3446	3546	3646	3746	3846	3946	
Cd.100	Flash ROM write request	5000						
Cd.101	Parameter initialization request	5001						

Buffer memory address											Memory area	
Axis 7	Axis 8	Axis 9	Axis 10	Axis 11	Axis 12	Axis 13	Axis 14	Axis 15	Axis 16			
4000	4100	4200	4300	4400	4500	4600	4700	4800	4900	Axis control data	Control data area	
4001	4101	4201	4301	4401	4501	4601	4701	4801	4901			
4002	4102	4202	4302	4402	4502	4602	4702	4802	4902			
4003	4103	4203	4303	4403	4503	4603	4703	4803	4903			
4004	4104	4204	4304	4404	4504	4604	4704	4804	4904			
4005	4105	4205	4305	4405	4505	4605	4705	4805	4905			
4008	4108	4208	4308	4408	4508	4608	4708	4808	4908			
4009	4109	4209	4309	4409	4509	4609	4709	4809	4909			
4011	4111	4211	4311	4411	4511	4611	4711	4811	4911			
4012	4112	4212	4312	4412	4512	4612	4712	4812	4912			
4013	4113	4213	4313	4413	4513	4613	4713	4813	4913			
4015	4115	4215	4315	4415	4515	4615	4715	4815	4915			
4016	4116	4216	4316	4416	4516	4616	4716	4816	4916			
4017	4117	4217	4317	4417	4517	4617	4717	4817	4917			
4018	4118	4218	4318	4418	4518	4618	4718	4818	4918			
4019	4119	4219	4319	4419	4519	4619	4719	4819	4919			
4020	4120	4220	4320	4420	4520	4620	4720	4820	4920			
4021	4121	4221	4321	4421	4521	4621	4721	4821	4921			
4023	4123	4223	4323	4423	4523	4623	4723	4823	4923			
4024	4124	4224	4324	4424	4524	4624	4724	4824	4924			
4025	4125	4225	4325	4425	4525	4625	4725	4825	4925			
4028	4128	4228	4328	4428	4528	4628	4728	4828	4928			
4029	4129	4229	4329	4429	4529	4629	4729	4829	4929			
4030	4130	4230	4330	4430	4530	4630	4730	4830	4930			
4046	4146	4246	4346	4446	4546	4646	4746	4846	4946			
5000											System control data	
5001												

Appendix 3.4 Positioning data area

Data No.	Symbol	Item	Buffer memory address						
			Axis 1	Axis 2	Axis 3	Axis 4	Axis 5	Axis 6	
1	Da.0	Operation pattern	5100	5420	5740	6060	6380	6700	
	Da.1	Control system	5101	5421	5741	6061	6381	6701	
	Da.2	Acceleration time	5102	5422	5742	6062	6382	6702	
	Da.3	Deceleration time	5103	5423	5743	6063	6383	6703	
	Da.4	Command speed	5104 5105	5424 5425	5744 5745	6064 6065	6384 6385	6704 6705	
	Da.6	Positioning address/movement amount	5106 5107	5426 5427	5746 5747	6066 6067	6386 6387	6706 6707	
	Da.8	Dwell time	5108	5428	5748	6068	6388	6708	
2	Da.0	Operation pattern	5110	5430	5750	6070	6390	6710	
	Da.1	Control system	5111	5431	5751	6071	6391	6711	
	Da.2	Acceleration time	5112	5432	5752	6072	6392	6712	
	Da.3	Deceleration time	5113	5433	5753	6073	6393	6713	
	Da.4	Command speed	5114 5115	5434 5435	5754 5755	6074 6075	6394 6395	6714 6715	
	Da.6	Positioning address/movement amount	5116 5117	5436 5437	5756 5757	6076 6077	6396 6397	6716 6717	
	Da.8	Dwell time	5118	5438	5758	6078	6398	6718	
3	Da.0	Operation pattern	5120	5440	5760	6080	6400	6720	
	Da.1	Control system	5121	5441	5761	6081	6401	6721	
	Da.2	Acceleration time	5122	5442	5762	6082	6402	6722	
	Da.3	Deceleration time	5123	5443	5763	6083	6403	6723	
	Da.4	Command speed	5124 5125	5444 5445	5764 5765	6084 6085	6404 6405	6724 6725	
	Da.6	Positioning address/movement amount	5126 5127	5446 5447	5766 5767	6086 6087	6406 6407	6726 6727	
	Da.8	Dwell time	5128	5448	5768	6088	6408	6728	
4	Da.0	Operation pattern	5130	5450	5770	6090	6410	6730	
	Da.1	Control system	5131	5451	5771	6091	6411	6731	
	Da.2	Acceleration time	5132	5452	5772	6092	6412	6732	
	Da.3	Deceleration time	5133	5453	5773	6093	6413	6733	
	Da.4	Command speed	5134 5135	5454 5455	5774 5775	6094 6095	6414 6415	6734 6735	
	Da.6	Positioning address/movement amount	5136 5137	5456 5457	5776 5777	6096 6097	6416 6417	6736 6737	
	Da.8	Dwell time	5138	5458	5778	6098	6418	6738	
5	Da.0	Operation pattern	5140	5460	5780	6100	6420	6740	
	Da.1	Control system	5141	5461	5781	6101	6421	6741	
	Da.2	Acceleration time	5142	5462	5782	6102	6422	6742	
	Da.3	Deceleration time	5143	5463	5783	6103	6423	6743	
	Da.4	Command speed	5144 5145	5464 5465	5784 5785	6104 6105	6424 6425	6744 6745	
	Da.6	Positioning address/movement amount	5146 5147	5466 5467	5786 5787	6106 6107	6426 6427	6746 6747	
	Da.8	Dwell time	5148	5468	5788	6108	6428	6748	

Buffer memory address											Memory area
Axis 7	Axis 8	Axis 9	Axis 10	Axis 11	Axis 12	Axis 13	Axis 14	Axis 15	Axis 16		
7020	7340	7660	7980	8300	8620	8940	9260	9580	9900	Positioning data Positioning data area	
7021	7341	7661	7981	8301	8621	8941	9261	9581	9901		
7022	7342	7662	7982	8302	8622	8942	9262	9582	9902		
7023	7343	7663	7983	8303	8623	8943	9263	9583	9903		
7024	7344	7664	7984	8304	8624	8944	9264	9584	9904		
7025	7345	7665	7985	8305	8625	8945	9265	9585	9905		
7026	7346	7666	7986	8306	8626	8946	9266	9586	9906		
7027	7347	7667	7987	8307	8627	8947	9267	9587	9907		
7028	7348	7668	7988	8308	8628	8948	9268	9588	9908		
7030	7350	7670	7990	8310	8630	8950	9270	9590	9910		
7031	7351	7671	7991	8311	8631	8951	9271	9591	9911		
7032	7352	7672	7992	8312	8632	8952	9272	9592	9912		
7033	7353	7673	7993	8313	8633	8953	9273	9593	9913		
7034	7354	7674	7994	8314	8634	8954	9274	9594	9914		
7035	7355	7675	7995	8315	8635	8955	9275	9595	9915		
7036	7356	7676	7996	8316	8636	8956	9276	9596	9916		
7037	7357	7677	7997	8317	8637	8957	9277	9597	9917		
7038	7358	7678	7998	8318	8638	8958	9278	9598	9918		
7040	7360	7680	8000	8320	8640	8960	9280	9600	9920		
7041	7361	7681	8001	8321	8641	8961	9281	9601	9921		
7042	7362	7682	8002	8322	8642	8962	9282	9602	9922		
7043	7363	7683	8003	8323	8643	8963	9283	9603	9923		
7044	7364	7684	8004	8324	8644	8964	9284	9604	9924		
7045	7365	7685	8005	8325	8645	8965	9285	9605	9925		
7046	7366	7686	8006	8326	8646	8966	9286	9606	9926		
7047	7367	7687	8007	8327	8647	8967	9287	9607	9927		
7048	7368	7688	8008	8328	8648	8968	9288	9608	9928		
7050	7370	7690	8010	8330	8650	8970	9290	9610	9930		
7051	7371	7691	8011	8331	8651	8971	9291	9611	9931		
7052	7372	7692	8012	8332	8652	8972	9292	9612	9932		
7053	7373	7693	8013	8333	8653	8973	9293	9613	9933		
7054	7374	7694	8014	8334	8654	8974	9294	9614	9934		
7055	7375	7695	8015	8335	8655	8975	9295	9615	9935		
7056	7376	7696	8016	8336	8656	8976	9296	9616	9936		
7057	7377	7697	8017	8337	8657	8977	9297	9617	9937		
7058	7378	7698	8018	8338	8658	8978	9298	9618	9938		
7060	7380	7700	8020	8340	8660	8980	9300	9620	9940		
7061	7381	7701	8021	8341	8661	8981	9301	9621	9941		
7062	7382	7702	8022	8342	8662	8982	9302	9622	9942		
7063	7383	7703	8023	8343	8663	8983	9303	9623	9943		
7064	7384	7704	8024	8344	8664	8984	9304	9624	9944		
7065	7385	7705	8025	8345	8665	8985	9305	9625	9945		
7066	7386	7706	8026	8346	8666	8986	9306	9626	9946		
7067	7387	7707	8027	8347	8667	8987	9307	9627	9947		
7068	7388	7708	8028	8348	8668	8988	9308	9628	9948		

Data No.	Symbol	Item	Buffer memory address						
			Axis 1	Axis 2	Axis 3	Axis 4	Axis 5	Axis 6	
6	Da.0	Operation pattern	5150	5470	5790	6110	6430	6750	
	Da.1	Control system	5151	5471	5791	6111	6431	6751	
	Da.2	Acceleration time	5152	5472	5792	6112	6432	6752	
	Da.3	Deceleration time	5153	5473	5793	6113	6433	6753	
	Da.4	Command speed	5154	5474	5794	6114	6434	6754	
			5155	5475	5795	6115	6435	6755	
	Da.6	Positioning address/movement amount	5156	5476	5796	6116	6436	6756	
5157			5477	5797	6117	6437	6757		
Da.8	Dwell time	5158	5478	5798	6118	6438	6758		
7	Da.0	Operation pattern	5160	5480	5800	6120	6440	6760	
	Da.1	Control system	5161	5481	5801	6121	6441	6761	
	Da.2	Acceleration time	5162	5482	5802	6122	6442	6762	
	Da.3	Deceleration time	5163	5483	5803	6123	6443	6763	
	Da.4	Command speed	5164	5484	5804	6124	6444	6764	
			5165	5485	5805	6125	6445	6765	
	Da.6	Positioning address/movement amount	5166	5486	5806	6126	6446	6766	
5167			5487	5807	6127	6447	6767		
Da.8	Dwell time	5168	5488	5808	6128	6448	6768		
8	Da.0	Operation pattern	5170	5490	5810	6130	6450	6770	
	Da.1	Control system	5171	5491	5811	6131	6451	6771	
	Da.2	Acceleration time	5172	5492	5812	6132	6452	6772	
	Da.3	Deceleration time	5173	5493	5813	6133	6453	6773	
	Da.4	Command speed	5174	5494	5814	6134	6454	6774	
			5175	5495	5815	6135	6455	6775	
	Da.6	Positioning address/movement amount	5176	5496	5816	6136	6456	6776	
5177			5497	5817	6137	6457	6777		
Da.8	Dwell time	5178	5498	5818	6138	6458	6778		
9	Da.0	Operation pattern	5180	5500	5820	6140	6460	6780	
	Da.1	Control system	5181	5501	5821	6141	6461	6781	
	Da.2	Acceleration time	5182	5502	5822	6142	6462	6782	
	Da.3	Deceleration time	5183	5503	5823	6143	6463	6783	
	Da.4	Command speed	5184	5504	5824	6144	6464	6784	
			5185	5505	5825	6145	6465	6785	
	Da.6	Positioning address/movement amount	5186	5506	5826	6146	6466	6786	
5187			5507	5827	6147	6467	6787		
Da.8	Dwell time	5188	5508	5828	6148	6468	6788		
10	Da.0	Operation pattern	5190	5510	5830	6150	6470	6790	
	Da.1	Control system	5191	5511	5831	6151	6471	6791	
	Da.2	Acceleration time	5192	5512	5832	6152	6472	6792	
	Da.3	Deceleration time	5193	5513	5833	6153	6473	6793	
	Da.4	Command speed	5194	5514	5834	6154	6474	6794	
			5195	5515	5835	6155	6475	6795	
	Da.6	Positioning address/movement amount	5196	5516	5836	6156	6476	6796	
5197			5517	5837	6157	6477	6797		
Da.8	Dwell time	5198	5518	5838	6158	6478	6798		

	Buffer memory address										Memory area
	Axis 7	Axis 8	Axis 9	Axis 10	Axis 11	Axis 12	Axis 13	Axis 14	Axis 15	Axis 16	
	7070	7390	7710	8030	8350	8670	8990	9310	9630	9950	Positioning data Positioning data area
	7071	7391	7711	8031	8351	8671	8991	9311	9631	9951	
	7072	7392	7712	8032	8352	8672	8992	9312	9632	9952	
	7073	7393	7713	8033	8353	8673	8993	9313	9633	9953	
	7074	7394	7714	8034	8354	8674	8994	9314	9634	9954	
	7075	7395	7715	8035	8355	8675	8995	9315	9635	9955	
	7076	7396	7716	8036	8356	8676	8996	9316	9636	9956	
	7077	7397	7717	8037	8357	8677	8997	9317	9637	9957	
	7078	7398	7718	8038	8358	8678	8998	9318	9638	9958	
	7080	7400	7720	8040	8360	8680	9000	9320	9640	9960	
	7081	7401	7721	8041	8361	8681	9001	9321	9641	9961	
	7082	7402	7722	8042	8362	8682	9002	9322	9642	9962	
	7083	7403	7723	8043	8363	8683	9003	9323	9643	9963	
	7084	7404	7724	8044	8364	8684	9004	9324	9644	9964	
	7085	7405	7725	8045	8365	8685	9005	9325	9645	9965	
	7086	7406	7726	8046	8366	8686	9006	9326	9646	9966	
	7087	7407	7727	8047	8367	8687	9007	9327	9647	9967	
	7088	7408	7728	8048	8368	8688	9008	9328	9648	9968	
	7090	7410	7730	8050	8370	8690	9010	9330	9650	9970	
	7091	7411	7731	8051	8371	8691	9011	9331	9651	9971	
	7092	7412	7732	8052	8372	8692	9012	9332	9652	9972	
	7093	7413	7733	8053	8373	8693	9013	9333	9653	9973	
	7094	7414	7734	8054	8374	8694	9014	9334	9654	9974	
	7095	7415	7735	8055	8375	8695	9015	9335	9655	9975	
	7096	7416	7736	8056	8376	8696	9016	9336	9656	9976	
	7097	7417	7737	8057	8377	8697	9017	9337	9657	9977	
	7098	7418	7738	8058	8378	8698	9018	9338	9658	9978	
	7100	7420	7740	8060	8380	8700	9020	9340	9660	9980	
	7101	7421	7741	8061	8381	8701	9021	9341	9661	9981	
	7102	7422	7742	8062	8382	8702	9022	9342	9662	9982	
	7103	7423	7743	8063	8383	8703	9023	9343	9663	9983	
	7104	7424	7744	8064	8384	8704	9024	9344	9664	9984	
	7105	7425	7745	8065	8385	8705	9025	9345	9665	9985	
	7106	7426	7746	8066	8386	8706	9026	9346	9666	9986	
	7107	7427	7747	8067	8387	8707	9027	9347	9667	9987	
	7108	7428	7748	8068	8388	8708	9028	9348	9668	9988	
	7110	7430	7750	8070	8390	8710	9030	9350	9670	9990	
	7111	7431	7751	8071	8391	8711	9031	9351	9671	9991	
	7112	7432	7752	8072	8392	8712	9032	9352	9672	9992	
	7113	7433	7753	8073	8393	8713	9033	9353	9673	9993	
	7114	7434	7754	8074	8394	8714	9034	9354	9674	9994	
	7115	7435	7755	8075	8395	8715	9035	9355	9675	9995	
	7116	7436	7756	8076	8396	8716	9036	9356	9676	9996	
	7117	7437	7757	8077	8397	8717	9037	9357	9677	9997	
	7118	7438	7758	8078	8398	8718	9038	9358	9678	9998	

Data No.	Symbol	Item	Buffer memory address							
			Axis 1	Axis 2	Axis 3	Axis 4	Axis 5	Axis 6		
11	Da.0	Operation pattern	5200	5520	5840	6160	6480	6800		
	Da.1	Control system	5201	5521	5841	6161	6481	6801		
	Da.2	Acceleration time	5202	5522	5842	6162	6482	6802		
	Da.3	Deceleration time	5203	5523	5843	6163	6483	6803		
	Da.4	Command speed	5204	5524	5844	6164	6484	6804		
				5205	5525	5845	6165	6485	6805	
	Da.6	Positioning address/movement amount	5206	5526	5846	6166	6486	6806		
			5207	5527	5847	6167	6487	6807		
Da.8	Dwell time		5208	5528	5848	6168	6488	6808		
12	Da.0	Operation pattern	5210	5530	5850	6170	6490	6810		
	Da.1	Control system	5211	5531	5851	6171	6491	6811		
	Da.2	Acceleration time	5212	5532	5852	6172	6492	6812		
	Da.3	Deceleration time	5213	5533	5853	6173	6493	6813		
	Da.4	Command speed	5214	5534	5854	6174	6494	6814		
				5215	5535	5855	6175	6495	6815	
	Da.6	Positioning address/movement amount	5216	5536	5856	6176	6496	6816		
			5217	5537	5857	6177	6497	6817		
Da.8	Dwell time		5218	5538	5858	6178	6498	6818		
13	Da.0	Operation pattern	5220	5540	5860	6180	6500	6820		
	Da.1	Control system	5221	5541	5861	6181	6501	6821		
	Da.2	Acceleration time	5222	5542	5862	6182	6502	6822		
	Da.3	Deceleration time	5223	5543	5863	6183	6503	6823		
	Da.4	Command speed	5224	5544	5864	6184	6504	6824		
				5225	5545	5865	6185	6505	6825	
	Da.6	Positioning address/movement amount	5226	5546	5866	6186	6506	6826		
			5227	5547	5867	6187	6507	6827		
Da.8	Dwell time		5228	5548	5868	6188	6508	6828		
14	Da.0	Operation pattern	5230	5550	5870	6190	6510	6830		
	Da.1	Control system	5231	5551	5871	6191	6511	6831		
	Da.2	Acceleration time	5232	5552	5872	6192	6512	6832		
	Da.3	Deceleration time	5233	5553	5873	6193	6513	6833		
	Da.4	Command speed	5234	5554	5874	6194	6514	6834		
				5235	5555	5875	6195	6515	6835	
	Da.6	Positioning address/movement amount	5236	5556	5876	6196	6516	6836		
			5237	5557	5877	6197	6517	6837		
Da.8	Dwell time		5238	5558	5878	6198	6518	6838		
15	Da.0	Operation pattern	5240	5560	5880	6200	6520	6840		
	Da.1	Control system	5241	5561	5881	6201	6521	6841		
	Da.2	Acceleration time	5242	5562	5882	6202	6522	6842		
	Da.3	Deceleration time	5243	5563	5883	6203	6523	6843		
	Da.4	Command speed	5244	5564	5884	6204	6524	6844		
				5245	5565	5885	6205	6525	6845	
	Da.6	Positioning address/movement amount	5246	5566	5886	6206	6526	6846		
			5247	5567	5887	6207	6527	6847		
Da.8	Dwell time		5248	5568	5888	6208	6528	6848		

	Buffer memory address										Memory area
	Axis 7	Axis 8	Axis 9	Axis 10	Axis 11	Axis 12	Axis 13	Axis 14	Axis 15	Axis 16	
	7120	7440	7760	8080	8400	8720	9040	9360	9680	10000	Positioning data Positioning data area
	7121	7441	7761	8081	8401	8721	9041	9361	9681	10001	
	7122	7442	7762	8082	8402	8722	9042	9362	9682	10002	
	7123	7443	7763	8083	8403	8723	9043	9363	9683	10003	
	7124	7444	7764	8084	8404	8724	9044	9364	9684	10004	
	7125	7445	7765	8085	8405	8725	9045	9365	9685	10005	
	7126	7446	7766	8086	8406	8726	9046	9366	9686	10006	
	7127	7447	7767	8087	8407	8727	9047	9367	9687	10007	
	7128	7448	7768	8088	8408	8728	9048	9368	9688	10008	
	7130	7450	7770	8090	8410	8730	9050	9370	9690	10010	
	7131	7451	7771	8091	8411	8731	9051	9371	9691	10011	
	7132	7452	7772	8092	8412	8732	9052	9372	9692	10012	
	7133	7453	7773	8093	8413	8733	9053	9373	9693	10013	
	7134	7454	7774	8094	8414	8734	9054	9374	9694	10014	
	7135	7455	7775	8095	8415	8735	9055	9375	9695	10015	
	7136	7456	7776	8096	8416	8736	9056	9376	9696	10016	
	7137	7457	7777	8097	8417	8737	9057	9377	9697	10017	
	7138	7458	7778	8098	8418	8738	9058	9378	9698	10018	
	7140	7460	7780	8100	8420	8740	9060	9380	9700	10020	
	7141	7461	7781	8101	8421	8741	9061	9381	9701	10021	
	7142	7462	7782	8102	8422	8742	9062	9382	9702	10022	
	7143	7463	7783	8103	8423	8743	9063	9383	9703	10023	
	7144	7464	7784	8104	8424	8744	9064	9384	9704	10024	
	7145	7465	7785	8105	8425	8745	9065	9385	9705	10025	
	7146	7466	7786	8106	8426	8746	9066	9386	9706	10026	
	7147	7467	7787	8107	8427	8747	9067	9387	9707	10027	
	7148	7468	7788	8108	8428	8748	9068	9388	9708	10028	
	7150	7470	7790	8110	8430	8750	9070	9390	9710	10030	
	7151	7471	7791	8111	8431	8751	9071	9391	9711	10031	
	7152	7472	7792	8112	8432	8752	9072	9392	9712	10032	
	7153	7473	7793	8113	8433	8753	9073	9393	9713	10033	
	7154	7474	7794	8114	8434	8754	9074	9394	9714	10034	
	7155	7475	7795	8115	8435	8755	9075	9395	9715	10035	
	7156	7476	7796	8116	8436	8756	9076	9396	9716	10036	
	7157	7477	7797	8117	8437	8757	9077	9397	9717	10037	
	7158	7478	7798	8118	8438	8758	9078	9398	9718	10038	
	7160	7480	7800	8120	8440	8760	9080	9400	9720	10040	
	7161	7481	7801	8121	8441	8761	9081	9401	9721	10041	
	7162	7482	7802	8122	8442	8762	9082	9402	9722	10042	
	7163	7483	7803	8123	8443	8763	9083	9403	9723	10043	
	7164	7484	7804	8124	8444	8764	9084	9404	9724	10044	
	7165	7485	7805	8125	8445	8765	9085	9405	9725	10045	
	7166	7486	7806	8126	8446	8766	9086	9406	9726	10046	
	7167	7487	7807	8127	8447	8767	9087	9407	9727	10047	
	7168	7488	7808	8128	8448	8768	9088	9408	9728	10048	

Data No.	Symbol	Item	Buffer memory address						
			Axis 1	Axis 2	Axis 3	Axis 4	Axis 5	Axis 6	
16	Da.0	Operation pattern	5250	5570	5890	6210	6530	6850	
	Da.1	Control system	5251	5571	5891	6211	6531	6851	
	Da.2	Acceleration time	5252	5572	5892	6212	6532	6852	
	Da.3	Deceleration time	5253	5573	5893	6213	6533	6853	
	Da.4	Command speed	5254	5574	5894	6214	6534	6854	
			5255	5575	5895	6215	6535	6855	
	Da.6	Positioning address/movement amount	5256	5576	5896	6216	6536	6856	
5257			5577	5897	6217	6537	6857		
Da.8	Dwell time	5258	5578	5898	6218	6538	6858		
17	Da.0	Operation pattern	5260	5580	5900	6220	6540	6860	
	Da.1	Control system	5261	5581	5901	6221	6541	6861	
	Da.2	Acceleration time	5262	5582	5902	6222	6542	6862	
	Da.3	Deceleration time	5263	5583	5903	6223	6543	6863	
	Da.4	Command speed	5264	5584	5904	6224	6544	6864	
			5265	5585	5905	6225	6545	6865	
	Da.6	Positioning address/movement amount	5266	5586	5906	6226	6546	6866	
5267			5587	5907	6227	6547	6867		
Da.8	Dwell time	5268	5588	5908	6228	6548	6868		
18	Da.0	Operation pattern	5270	5590	5910	6230	6550	6870	
	Da.1	Control system	5271	5591	5911	6231	6551	6871	
	Da.2	Acceleration time	5272	5592	5912	6232	6552	6872	
	Da.3	Deceleration time	5273	5593	5913	6233	6553	6873	
	Da.4	Command speed	5274	5594	5914	6234	6554	6874	
			5275	5595	5915	6235	6555	6875	
	Da.6	Positioning address/movement amount	5276	5596	5916	6236	6556	6876	
5277			5597	5917	6237	6557	6877		
Da.8	Dwell time	5278	5598	5918	6238	6558	6878		
19	Da.0	Operation pattern	5280	5600	5920	6240	6560	6880	
	Da.1	Control system	5281	5601	5921	6241	6561	6881	
	Da.2	Acceleration time	5282	5602	5922	6242	6562	6882	
	Da.3	Deceleration time	5283	5603	5923	6243	6563	6883	
	Da.4	Command speed	5284	5604	5924	6244	6564	6884	
			5285	5605	5925	6245	6565	6885	
	Da.6	Positioning address/movement amount	5286	5606	5926	6246	6566	6886	
5287			5607	5927	6247	6567	6887		
Da.8	Dwell time	5288	5608	5928	6248	6568	6888		
20	Da.0	Operation pattern	5290	5610	5930	6250	6570	6890	
	Da.1	Control system	5291	5611	5931	6251	6571	6891	
	Da.2	Acceleration time	5292	5612	5932	6252	6572	6892	
	Da.3	Deceleration time	5293	5613	5933	6253	6573	6893	
	Da.4	Command speed	5294	5614	5934	6254	6574	6894	
			5295	5615	5935	6255	6575	6895	
	Da.6	Positioning address/movement amount	5296	5616	5936	6256	6576	6896	
5297			5617	5937	6257	6577	6897		
Da.8	Dwell time	5298	5618	5938	6258	6578	6898		

	Buffer memory address										Memory area
	Axis 7	Axis 8	Axis 9	Axis 10	Axis 11	Axis 12	Axis 13	Axis 14	Axis 15	Axis 16	
	7170	7490	7810	8130	8450	8770	9090	9410	9730	10050	Positioning data Positioning data area
	7171	7491	7811	8131	8451	8771	9091	9411	9731	10051	
	7172	7492	7812	8132	8452	8772	9092	9412	9732	10052	
	7173	7493	7813	8133	8453	8773	9093	9413	9733	10053	
	7174	7494	7814	8134	8454	8774	9094	9414	9734	10054	
	7175	7495	7815	8135	8455	8775	9095	9415	9735	10055	
	7176	7496	7816	8136	8456	8776	9096	9416	9736	10056	
	7177	7497	7817	8137	8457	8777	9097	9417	9737	10057	
	7178	7498	7818	8138	8458	8778	9098	9418	9738	10058	
	7180	7500	7820	8140	8460	8780	9100	9420	9740	10060	
	7181	7501	7821	8141	8461	8781	9101	9421	9741	10061	
	7182	7502	7822	8142	8462	8782	9102	9422	9742	10062	
	7183	7503	7823	8143	8463	8783	9103	9423	9743	10063	
	7184	7504	7824	8144	8464	8784	9104	9424	9744	10064	
	7185	7505	7825	8145	8465	8785	9105	9425	9745	10065	
	7186	7506	7826	8146	8466	8786	9106	9426	9746	10066	
	7187	7507	7827	8147	8467	8787	9107	9427	9747	10067	
	7188	7508	7828	8148	8468	8788	9108	9428	9748	10068	
	7190	7510	7830	8150	8470	8790	9110	9430	9750	10070	
	7191	7511	7831	8151	8471	8791	9111	9431	9751	10071	
	7192	7512	7832	8152	8472	8792	9112	9432	9752	10072	
	7193	7513	7833	8153	8473	8793	9113	9433	9753	10073	
	7194	7514	7834	8154	8474	8794	9114	9434	9754	10074	
	7195	7515	7835	8155	8475	8795	9115	9435	9755	10075	
	7196	7516	7836	8156	8476	8796	9116	9436	9756	10076	
	7197	7517	7837	8157	8477	8797	9117	9437	9757	10077	
	7198	7518	7838	8158	8478	8798	9118	9438	9758	10078	
	7200	7520	7840	8160	8480	8800	9120	9440	9760	10080	
	7201	7521	7841	8161	8481	8801	9121	9441	9761	10081	
	7202	7522	7842	8162	8482	8802	9122	9442	9762	10082	
	7203	7523	7843	8163	8483	8803	9123	9443	9763	10083	
	7204	7524	7844	8164	8484	8804	9124	9444	9764	10084	
	7205	7525	7845	8165	8485	8805	9125	9445	9765	10085	
	7206	7526	7846	8166	8486	8806	9126	9446	9766	10086	
	7207	7527	7847	8167	8487	8807	9127	9447	9767	10087	
	7208	7528	7848	8168	8488	8808	9128	9448	9768	10088	
	7210	7530	7850	8170	8490	8810	9130	9450	9770	10090	
	7211	7531	7851	8171	8491	8811	9131	9451	9771	10091	
	7212	7532	7852	8172	8492	8812	9132	9452	9772	10092	
	7213	7533	7853	8173	8493	8813	9133	9453	9773	10093	
	7214	7534	7854	8174	8494	8814	9134	9454	9774	10094	
	7215	7535	7855	8175	8495	8815	9135	9455	9775	10095	
	7216	7536	7856	8176	8496	8816	9136	9456	9776	10096	
	7217	7537	7857	8177	8497	8817	9137	9457	9777	10097	
	7218	7538	7858	8178	8498	8818	9138	9458	9778	10098	

Data No.	Symbol	Item	Buffer memory address							
			Axis 1	Axis 2	Axis 3	Axis 4	Axis 5	Axis 6		
21	Da.0	Operation pattern	5300	5620	5940	6260	6580	6900		
	Da.1	Control system	5301	5621	5941	6261	6581	6901		
	Da.2	Acceleration time	5302	5622	5942	6262	6582	6902		
	Da.3	Deceleration time	5303	5623	5943	6263	6583	6903		
	Da.4	Command speed	5304	5624	5944	6264	6584	6904		
				5305	5625	5945	6265	6585	6905	
	Da.6	Positioning address/movement amount	5306	5626	5946	6266	6586	6906		
			5307	5627	5947	6267	6587	6907		
	Da.8	Dwell time	5308	5628	5948	6268	6588	6908		
22	Da.0	Operation pattern	5310	5630	5950	6270	6590	6910		
	Da.1	Control system	5311	5631	5951	6271	6591	6911		
	Da.2	Acceleration time	5312	5632	5952	6272	6592	6912		
	Da.3	Deceleration time	5313	5633	5953	6273	6593	6913		
	Da.4	Command speed	5314	5634	5954	6274	6594	6914		
				5315	5635	5955	6275	6595	6915	
	Da.6	Positioning address/movement amount	5316	5636	5956	6276	6596	6916		
			5317	5637	5957	6277	6597	6917		
	Da.8	Dwell time	5318	5638	5958	6278	6598	6918		
23	Da.0	Operation pattern	5320	5640	5960	6280	6600	6920		
	Da.1	Control system	5321	5641	5961	6281	6601	6921		
	Da.2	Acceleration time	5322	5642	5962	6282	6602	6922		
	Da.3	Deceleration time	5323	5643	5963	6283	6603	6923		
	Da.4	Command speed	5324	5644	5964	6284	6604	6924		
				5325	5645	5965	6285	6605	6925	
	Da.6	Positioning address/movement amount	5326	5646	5966	6286	6606	6926		
			5327	5647	5967	6287	6607	6927		
	Da.8	Dwell time	5328	5648	5968	6288	6608	6928		
24	Da.0	Operation pattern	5330	5650	5970	6290	6610	6930		
	Da.1	Control system	5331	5651	5971	6291	6611	6931		
	Da.2	Acceleration time	5332	5652	5972	6292	6612	6932		
	Da.3	Deceleration time	5333	5653	5973	6293	6613	6933		
	Da.4	Command speed	5334	5654	5974	6294	6614	6934		
				5335	5655	5975	6295	6615	6935	
	Da.6	Positioning address/movement amount	5336	5656	5976	6296	6616	6936		
			5337	5657	5977	6297	6617	6937		
	Da.8	Dwell time	5338	5658	5978	6298	6618	6938		
25	Da.0	Operation pattern	5340	5660	5980	6300	6620	6940		
	Da.1	Control system	5341	5661	5981	6301	6621	6941		
	Da.2	Acceleration time	5342	5662	5982	6302	6622	6942		
	Da.3	Deceleration time	5343	5663	5983	6303	6623	6943		
	Da.4	Command speed	5344	5664	5984	6304	6624	6944		
				5345	5665	5985	6305	6625	6945	
	Da.6	Positioning address/movement amount	5346	5666	5986	6306	6626	6946		
			5347	5667	5987	6307	6627	6947		
	Da.8	Dwell time	5348	5668	5988	6308	6628	6948		

	Buffer memory address										Memory area
	Axis 7	Axis 8	Axis 9	Axis 10	Axis 11	Axis 12	Axis 13	Axis 14	Axis 15	Axis 16	
	7220	7540	7860	8180	8500	8820	9140	9460	9780	10100	Positioning data Positioning data area
	7221	7541	7861	8181	8501	8821	9141	9461	9781	10101	
	7222	7542	7862	8182	8502	8822	9142	9462	9782	10102	
	7223	7543	7863	8183	8503	8823	9143	9463	9783	10103	
	7224	7544	7864	8184	8504	8824	9144	9464	9784	10104	
	7225	7545	7865	8185	8505	8825	9145	9465	9785	10105	
	7226	7546	7866	8186	8506	8826	9146	9466	9786	10106	
	7227	7547	7867	8187	8507	8827	9147	9467	9787	10107	
	7228	7548	7868	8188	8508	8828	9148	9468	9788	10108	
	7230	7550	7870	8190	8510	8830	9150	9470	9790	10110	
	7231	7551	7871	8191	8511	8831	9151	9471	9791	10111	
	7232	7552	7872	8192	8512	8832	9152	9472	9792	10112	
	7233	7553	7873	8193	8513	8833	9153	9473	9793	10113	
	7234	7554	7874	8194	8514	8834	9154	9474	9794	10114	
	7235	7555	7875	8195	8515	8835	9155	9475	9795	10115	
	7236	7556	7876	8196	8516	8836	9156	9476	9796	10116	
	7237	7557	7877	8197	8517	8837	9157	9477	9797	10117	
	7238	7558	7878	8198	8518	8838	9158	9478	9798	10118	
	7240	7560	7880	8200	8520	8840	9160	9480	9800	10120	
	7241	7561	7881	8201	8521	8841	9161	9481	9801	10121	
	7242	7562	7882	8202	8522	8842	9162	9482	9802	10122	
	7243	7563	7883	8203	8523	8843	9163	9483	9803	10123	
	7244	7564	7884	8204	8524	8844	9164	9484	9804	10124	
	7245	7565	7885	8205	8525	8845	9165	9485	9805	10125	
	7246	7566	7886	8206	8526	8846	9166	9486	9806	10126	
	7247	7567	7887	8207	8527	8847	9167	9487	9807	10127	
	7248	7568	7888	8208	8528	8848	9168	9488	9808	10128	
	7250	7570	7890	8210	8530	8850	9170	9490	9810	10130	
	7251	7571	7891	8211	8531	8851	9171	9491	9811	10131	
	7252	7572	7892	8212	8532	8852	9172	9492	9812	10132	
	7253	7573	7893	8213	8533	8853	9173	9493	9813	10133	
	7254	7574	7894	8214	8534	8854	9174	9494	9814	10134	
	7255	7575	7895	8215	8535	8855	9175	9495	9815	10135	
	7256	7576	7896	8216	8536	8856	9176	9496	9816	10136	
	7257	7577	7897	8217	8537	8857	9177	9497	9817	10137	
	7258	7578	7898	8218	8538	8858	9178	9498	9818	10138	
	7260	7580	7900	8220	8540	8860	9180	9500	9820	10140	
	7261	7581	7901	8221	8541	8861	9181	9501	9821	10141	
	7262	7582	7902	8222	8542	8862	9182	9502	9822	10142	
	7263	7583	7903	8223	8543	8863	9183	9503	9823	10143	
	7264	7584	7904	8224	8544	8864	9184	9504	9824	10144	
	7265	7585	7905	8225	8545	8865	9185	9505	9825	10145	
	7266	7586	7906	8226	8546	8866	9186	9506	9826	10146	
	7267	7587	7907	8227	8547	8867	9187	9507	9827	10147	
	7268	7588	7908	8228	8548	8868	9188	9508	9828	10148	

Data No.	Symbol	Item	Buffer memory address						
			Axis 1	Axis 2	Axis 3	Axis 4	Axis 5	Axis 6	
26	Da.0	Operation pattern	5350	5670	5990	6310	6630	6950	
	Da.1	Control system	5351	5671	5991	6311	6631	6951	
	Da.2	Acceleration time	5352	5672	5992	6312	6632	6952	
	Da.3	Deceleration time	5353	5673	5993	6313	6633	6953	
	Da.4	Command speed	5354	5674	5994	6314	6634	6954	
			5355	5675	5995	6315	6635	6955	
	Da.6	Positioning address/movement amount	5356	5676	5996	6316	6636	6956	
		5357	5677	5997	6317	6637	6957		
Da.8	Dwell time	5358	5678	5998	6318	6638	6958		
27	Da.0	Operation pattern	5360	5680	6000	6320	6640	6960	
	Da.1	Control system	5361	5681	6001	6321	6641	6961	
	Da.2	Acceleration time	5362	5682	6002	6322	6642	6962	
	Da.3	Deceleration time	5363	5683	6003	6323	6643	6963	
	Da.4	Command speed	5364	5684	6004	6324	6644	6964	
			5365	5685	6005	6325	6645	6965	
	Da.6	Positioning address/movement amount	5366	5686	6006	6326	6646	6966	
		5367	5687	6007	6327	6647	6967		
Da.8	Dwell time	5368	5688	6008	6328	6648	6968		
28	Da.0	Operation pattern	5370	5690	6010	6330	6650	6970	
	Da.1	Control system	5371	5691	6011	6331	6651	6971	
	Da.2	Acceleration time	5372	5692	6012	6332	6652	6972	
	Da.3	Deceleration time	5373	5693	6013	6333	6653	6973	
	Da.4	Command speed	5374	5694	6014	6334	6654	6974	
			5375	5695	6015	6335	6655	6975	
	Da.6	Positioning address/movement amount	5376	5696	6016	6336	6656	6976	
		5377	5697	6017	6337	6657	6977		
Da.8	Dwell time	5378	5698	6018	6338	6658	6978		
29	Da.0	Operation pattern	5380	5700	6020	6340	6660	6980	
	Da.1	Control system	5381	5701	6021	6341	6661	6981	
	Da.2	Acceleration time	5382	5702	6022	6342	6662	6982	
	Da.3	Deceleration time	5383	5703	6023	6343	6663	6983	
	Da.4	Command speed	5384	5704	6024	6344	6664	6984	
			5385	5705	6025	6345	6665	6985	
	Da.6	Positioning address/movement amount	5386	5706	6026	6346	6666	6986	
		5387	5707	6027	6347	6667	6987		
Da.8	Dwell time	5388	5708	6028	6348	6668	6988		
30	Da.0	Operation pattern	5390	5710	6030	6350	6670	6990	
	Da.1	Control system	5391	5711	6031	6351	6671	6991	
	Da.2	Acceleration time	5392	5712	6032	6352	6672	6992	
	Da.3	Deceleration time	5393	5713	6033	6353	6673	6993	
	Da.4	Command speed	5394	5714	6034	6354	6674	6994	
			5395	5715	6035	6355	6675	6995	
	Da.6	Positioning address/movement amount	5396	5716	6036	6356	6676	6996	
		5397	5717	6037	6357	6677	6997		
Da.8	Dwell time	5398	5718	6038	6358	6678	6998		

	Buffer memory address										Memory area
	Axis 7	Axis 8	Axis 9	Axis 10	Axis 11	Axis 12	Axis 13	Axis 14	Axis 15	Axis 16	
	7270	7590	7910	8230	8550	8870	9190	9510	9830	10150	Positioning data Positioning data area
	7271	7591	7911	8231	8551	8871	9191	9511	9831	10151	
	7272	7592	7912	8232	8552	8872	9192	9512	9832	10152	
	7273	7593	7913	8233	8553	8873	9193	9513	9833	10153	
	7274	7594	7914	8234	8554	8874	9194	9514	9834	10154	
	7275	7595	7915	8235	8555	8875	9195	9515	9835	10155	
	7276	7596	7916	8236	8556	8876	9196	9516	9836	10156	
	7277	7597	7917	8237	8557	8877	9197	9517	9837	10157	
	7278	7598	7918	8238	8558	8878	9198	9518	9838	10158	
	7280	7600	7920	8240	8560	8880	9200	9520	9840	10160	
	7281	7601	7921	8241	8561	8881	9201	9521	9841	10161	
	7282	7602	7922	8242	8562	8882	9202	9522	9842	10162	
	7283	7603	7923	8243	8563	8883	9203	9523	9843	10163	
	7284	7604	7924	8244	8564	8884	9204	9524	9844	10164	
	7285	7605	7925	8245	8565	8885	9205	9525	9845	10165	
	7286	7606	7926	8246	8566	8886	9206	9526	9846	10166	
	7287	7607	7927	8247	8567	8887	9207	9527	9847	10167	
	7288	7608	7928	8248	8568	8888	9208	9528	9848	10168	
	7290	7610	7930	8250	8570	8890	9210	9530	9850	10170	
	7291	7611	7931	8251	8571	8891	9211	9531	9851	10171	
	7292	7612	7932	8252	8572	8892	9212	9532	9852	10172	
	7293	7613	7933	8253	8573	8893	9213	9533	9853	10173	
	7294	7614	7934	8254	8574	8894	9214	9534	9854	10174	
	7295	7615	7935	8255	8575	8895	9215	9535	9855	10175	
	7296	7616	7936	8256	8576	8896	9216	9536	9856	10176	
	7297	7617	7937	8257	8577	8897	9217	9537	9857	10177	
	7298	7618	7938	8258	8578	8898	9218	9538	9858	10178	
	7300	7620	7940	8260	8580	8900	9220	9540	9860	10180	
	7301	7621	7941	8261	8581	8901	9221	9541	9861	10181	
	7302	7622	7942	8262	8582	8902	9222	9542	9862	10182	
	7303	7623	7943	8263	8583	8903	9223	9543	9863	10183	
	7304	7624	7944	8264	8584	8904	9224	9544	9864	10184	
	7305	7625	7945	8265	8585	8905	9225	9545	9865	10185	
	7306	7626	7946	8266	8586	8906	9226	9546	9866	10186	
	7307	7627	7947	8267	8587	8907	9227	9547	9867	10187	
	7308	7628	7948	8268	8588	8908	9228	9548	9868	10188	
	7310	7630	7950	8270	8590	8910	9230	9550	9870	10190	
	7311	7631	7951	8271	8591	8911	9231	9551	9871	10191	
	7312	7632	7952	8272	8592	8912	9232	9552	9872	10192	
	7313	7633	7953	8273	8593	8913	9233	9553	9873	10193	
	7314	7634	7954	8274	8594	8914	9234	9554	9874	10194	
	7315	7635	7955	8275	8595	8915	9235	9555	9875	10195	
	7316	7636	7956	8276	8596	8916	9236	9556	9876	10196	
	7317	7637	7957	8277	8597	8917	9237	9557	9877	10197	
	7318	7638	7958	8278	8598	8918	9238	9558	9878	10198	

Data No.	Symbol	Item	Buffer memory address						
			Axis 1	Axis 2	Axis 3	Axis 4	Axis 5	Axis 6	
31	Da.0	Operation pattern	5400	5720	6040	6360	6680	7000	
	Da.1	Control system	5401	5721	6041	6361	6681	7001	
	Da.2	Acceleration time	5402	5722	6042	6362	6682	7002	
	Da.3	Deceleration time	5403	5723	6043	6363	6683	7003	
	Da.4	Command speed	5404	5724	6044	6364	6684	7004	
			5405	5725	6045	6365	6685	7005	
	Da.6	Positioning address/movement amount	5406	5726	6046	6366	6686	7006	
5407			5727	6047	6367	6687	7007		
Da.8	Dwell time	5408	5728	6048	6368	6688	7008		
32	Da.0	Operation pattern	5410	5730	6050	6370	6690	7010	
	Da.1	Control system	5411	5731	6051	6371	6691	7011	
	Da.2	Acceleration time	5412	5732	6052	6372	6692	7012	
	Da.3	Deceleration time	5413	5733	6053	6373	6693	7013	
	Da.4	Command speed	5414	5734	6054	6374	6694	7014	
			5415	5735	6055	6375	6695	7015	
	Da.6	Positioning address/movement amount	5416	5736	6056	6376	6696	7016	
5417			5737	6057	6377	6697	7017		
Da.8	Dwell time	5418	5738	6058	6378	6698	7018		

	Buffer memory address										Memory area	
	Axis 7	Axis 8	Axis 9	Axis 10	Axis 11	Axis 12	Axis 13	Axis 14	Axis 15	Axis 16	Positioning data	Positioning data area
	7320	7640	7960	8280	8600	8920	9240	9560	9880	10200		
	7321	7641	7961	8281	8601	8921	9241	9561	9881	10201		
	7322	7642	7962	8282	8602	8922	9242	9562	9882	10202		
	7323	7643	7963	8283	8603	8923	9243	9563	9883	10203		
	7324	7644	7964	8284	8604	8924	9244	9564	9884	10204		
	7325	7645	7965	8285	8605	8925	9245	9565	9885	10205		
	7326	7646	7966	8286	8606	8926	9246	9566	9886	10206		
	7327	7647	7967	8287	8607	8927	9247	9567	9887	10207		
	7328	7648	7968	8288	8608	8928	9248	9568	9888	10208		
	7330	7650	7970	8290	8610	8930	9250	9570	9890	10210		
	7331	7651	7971	8291	8611	8931	9251	9571	9891	10211		
	7332	7652	7972	8292	8612	8932	9252	9572	9892	10212		
	7333	7653	7973	8293	8613	8933	9253	9573	9893	10213		
	7334	7654	7974	8294	8614	8934	9254	9574	9894	10214		
	7335	7655	7975	8295	8615	8935	9255	9575	9895	10215		
	7336	7656	7976	8296	8616	8936	9256	9576	9896	10216		
	7337	7657	7977	8297	8617	8937	9257	9577	9897	10217		
	7338	7658	7978	8298	8618	8938	9258	9578	9898	10218		

Appendix 3.5 Servo parameter area

Symbol	No.	Default value	Item	Buffer memory address					
				Axis 1	Axis 2	Axis 3	Axis 4	Axis 5	Axis 6
Pr.300	—	0	Servo series	10300	10600	10900	11200	11500	11800
Pr.301	PA01	0000h	For manufacturer setting	10301	10601	10901	11201	11501	11801
Pr.302	PA02	0000h	Regenerative option	10302	10602	10902	11202	11502	11802
Pr.303	PA03	0000h	Absolute position detection system	10303	10603	10903	11203	11503	11803
Pr.304	PA04	0000h	Function selection A-1	10304	10604	10904	11204	11504	11804
Pr.305	PA05	0	For manufacturer setting	10305	10605	10905	11205	11505	11805
Pr.306	PA06	1		10306	10606	10906	11206	11506	11806
Pr.307	PA07	1		10307	10607	10907	11207	11507	11807
Pr.308	PA08	0001h	Auto tuning mode	10308	10608	10908	11208	11508	11808
Pr.309	PA09	12	Auto tuning response	10309	10609	10909	11209	11509	11809
Pr.310	PA10	100	In-position range	10310	10610	10910	11210	11510	11810
Pr.311	PA11	10000	For manufacturer setting	10311	10611	10911	11211	11511	11811
Pr.312	PA12	10000		10312	10612	10912	11212	11512	11812
Pr.313	PA13	0000h		10313	10613	10913	11213	11513	11813
Pr.314	PA14	0	Rotation direction selection	10314	10614	10914	11214	11514	11814
Pr.315	PA15	4000	Encoder output pulses	10315	10615	10915	11215	11515	11815
Pr.316	PA16	0	For manufacturer setting	10316	10616	10916	11216	11516	11816
Pr.317	PA17	0000h		10317	10617	10917	11217	11517	11817
Pr.318	PA18	0000h		10318	10618	10918	11218	11518	11818
Pr.319	PA19	000Bh		10319	10619	10919	11219	11519	11819
Pr.333	PB01	0000h	Adaptive tuning mode (Adaptive filter II)	10333	10633	10933	11233	11533	11833
Pr.334	PB02	0000h	Vibration suppression control tuning mode (advanced vibration suppression control)	10334	10634	10934	11234	11534	11834
Pr.335	PB03	0	For manufacturer setting	10335	10635	10935	11235	11535	11835
Pr.336	PB04	0	Feed forward gain	10336	10636	10936	11236	11536	11836
Pr.337	PB05	500	For manufacturer setting	10337	10637	10937	11237	11537	11837
Pr.338	PB06	70	Ratio of load inertia moment to servo motor inertia moment	10338	10638	10938	11238	11538	11838
Pr.339	PB07	24	Model loop gain	10339	10639	10939	11239	11539	11839
Pr.340	PB08	37	Position loop gain	10340	10640	10940	11240	11540	11840
Pr.341	PB09	823	Speed loop gain	10341	10641	10941	11241	11541	11841
Pr.342	PB10	337	Speed integral compensation	10342	10642	10942	11242	11542	11842
Pr.343	PB11	980	Speed differential compensation	10343	10643	10943	11243	11543	11843
Pr.344	PB12	0	For manufacturer setting	10344	10644	10944	11244	11544	11844
Pr.345	PB13	4500	Machine resonance suppression filter 1	10345	10645	10945	11245	11545	11845
Pr.346	PB14	0000h	Notch shape selection 1	10346	10646	10946	11246	11546	11846
Pr.347	PB15	4500	Machine resonance suppression filter 2	10347	10647	10947	11247	11547	11847
Pr.348	PB16	0000h	Notch shape selection 2	10348	10648	10948	11248	11548	11848
Pr.349	PB17	□	Automatic setting parameter	10349	10649	10949	11249	11549	11849
Pr.350	PB18	3141	Low-pass filter setting	10350	10650	10950	11250	11550	11850
Pr.351	PB19	1000	Vibration suppression control vibration frequency setting	10351	10651	10951	11251	11551	11851
Pr.352	PB20	1000	Vibration suppression control resonance frequency setting	10352	10652	10952	11252	11552	11852

	Buffer memory address										Memory area
	Axis 7	Axis 8	Axis 9	Axis 10	Axis 11	Axis 12	Axis 13	Axis 14	Axis 15	Axis 16	
	12100	12400	12700	13000	13300	13600	13900	14200	14500	14800	Basic setting parameters
	12101	12401	12701	13001	13301	13601	13901	14201	14501	14801	
	12102	12402	12702	13002	13302	13602	13902	14202	14502	14802	
	12103	12403	12703	13003	13303	13603	13903	14203	14503	14803	
	12104	12404	12704	13004	13304	13604	13904	14204	14504	14804	
	12105	12405	12705	13005	13305	13605	13905	14205	14505	14805	
	12106	12406	12706	13006	13306	13606	13906	14206	14506	14806	
	12107	12407	12707	13007	13307	13607	13907	14207	14507	14807	
	12108	12408	12708	13008	13308	13608	13908	14208	14508	14808	
	12109	12409	12709	13009	13309	13609	13909	14209	14509	14809	
	12110	12410	12710	13010	13310	13610	13910	14210	14510	14810	
	12111	12411	12711	13011	13311	13611	13911	14211	14511	14811	
	12112	12412	12712	13012	13312	13612	13912	14212	14512	14812	
	12113	12413	12713	13013	13313	13613	13913	14213	14513	14813	
	12114	12414	12714	13014	13314	13614	13914	14214	14514	14814	
	12115	12415	12715	13015	13315	13615	13915	14215	14515	14815	
	12116	12416	12716	13016	13316	13616	13916	14216	14516	14816	
	12117	12417	12717	13017	13317	13617	13917	14217	14517	14817	
	12118	12418	12718	13018	13318	13618	13918	14218	14518	14818	
	12119	12419	12719	13019	13319	13619	13919	14219	14519	14819	
	12133	12433	12733	13033	13333	13633	13933	14233	14533	14833	Servo parameter area
	12134	12434	12734	13034	13334	13634	13934	14234	14534	14834	
	12135	12435	12735	13035	13335	13635	13935	14235	14535	14835	
	12136	12436	12736	13036	13336	13636	13936	14236	14536	14836	
	12137	12437	12737	13037	13337	13637	13937	14237	14537	14837	
	12138	12438	12738	13038	13338	13638	13938	14238	14538	14838	
	12139	12439	12739	13039	13339	13639	13939	14239	14539	14839	
	12140	12440	12740	13040	13340	13640	13940	14240	14540	14840	
	12141	12441	12741	13041	13341	13641	13941	14241	14541	14841	
	12142	12442	12742	13042	13342	13642	13942	14242	14542	14842	
	12143	12443	12743	13043	13343	13643	13943	14243	14543	14843	
	12144	12444	12744	13044	13344	13644	13944	14244	14544	14844	
	12145	12445	12745	13045	13345	13645	13945	14245	14545	14845	
	12146	12446	12746	13046	13346	13646	13946	14246	14546	14846	
	12147	12447	12747	13047	13347	13647	13947	14247	14547	14847	
	12148	12448	12748	13048	13348	13648	13948	14248	14548	14848	
	12149	12449	12749	13049	13349	13649	13949	14249	14549	14849	
	12150	12450	12750	13050	13350	13650	13950	14250	14550	14850	
	12151	12451	12751	13051	13351	13651	13951	14251	14551	14851	
	12152	12452	12752	13052	13352	13652	13952	14252	14552	14852	
											Gain/filter parameters

Symbol	No.	Default value	Item	Buffer memory address					
				Axis 1	Axis 2	Axis 3	Axis 4	Axis 5	Axis 6
Pr.353	PB21	0	For manufacturer setting	10353	10653	10953	11253	11553	11853
Pr.354	PB22	0		10354	10654	10954	11254	11554	11854
Pr.355	PB23	0000h	Low-pass filter selection	10355	10655	10955	11255	11555	11855
Pr.356	PB24	0000h	Slight vibration suppression control selection	10356	10656	10956	11256	11556	11856
Pr.357	PB25	0000h	For manufacturer setting	10357	10657	10957	11257	11557	11857
Pr.358	PB26	0000h	Gain changing selection	10358	10658	10958	11258	11558	11858
Pr.359	PB27	10	Gain changing condition	10359	10659	10959	11259	11559	11859
Pr.360	PB28	1	Gain changing time constant	10360	10660	10960	11260	11560	11860
Pr.361	PB29	70	Gain changing ratio of load inertia moment to servomotor inertia moment	10361	10661	10961	11261	11561	11861
Pr.362	PB30	37	Gain changing position loop gain	10362	10662	10962	11262	11562	11862
Pr.363	PB31	823	Gain changing speed loop gain	10363	10663	10963	11263	11563	11863
Pr.364	PB32	337	Gain changing speed integral compensation	10364	10664	10964	11264	11564	11864
Pr.365	PB33	1000	Gain changing vibration suppression control vibration frequency setting	10365	10665	10965	11265	11565	11865
Pr.366	PB34	1000	Gain changing vibration suppression control resonance frequency setting	10366	10666	10966	11266	11566	11866
Pr.367	PB35	0	For manufacturer setting	10367	10667	10967	11267	11567	11867
Pr.368	PB36	0		10368	10668	10968	11268	11568	11868
Pr.369	PB37	100		10369	10669	10969	11269	11569	11869
Pr.370	PB38	0		10370	10670	10970	11270	11570	11870
Pr.371	PB39	0		10371	10671	10971	11271	11571	11871
Pr.372	PB40	0		10372	10672	10972	11272	11572	11872
Pr.373	PB41	1125		10373	10673	10973	11273	11573	11873
Pr.374	PB42	1125		10374	10674	10974	11274	11574	11874
Pr.375	PB43	0004h		10375	10675	10975	11275	11575	11875
Pr.376	PB44	0		10376	10676	10976	11276	11576	11876
Pr.377	PB45	0000h		10377	10677	10977	11277	11577	11877
Pr.381	PC01	3	Error excessive alarm level	10381	10681	10981	11281	11581	11881
Pr.382	PC02	0	Electromagnetic brake sequence output	10382	10682	10982	11282	11582	11882
Pr.383	PC03	0000h	Encoder output pulses selection	10383	10683	10983	11283	11583	11883
Pr.384	PC04	0000h	Function selection C-1	10384	10684	10984	11284	11584	11884
Pr.385	PC05	0000h	Function selection C-2	10385	10685	10985	11285	11585	11885
Pr.386	PC06	0000h	Function selection C-3	10386	10686	10986	11286	11586	11886
Pr.387	PC07	50	Zero speed	10387	10687	10987	11287	11587	11887
Pr.388	PC08	0	For manufacturer setting	10388	10688	10988	11288	11588	11888
Pr.389	PC09	0000h	Analog monitor 1 output	10389	10689	10989	11289	11589	11889
Pr.390	PC10	0001h	Analog monitor 2 output	10390	10690	10990	11290	11590	11890
Pr.391	PC11	0	Analog monitor 1 offset	10391	10691	10991	11291	11591	11891
Pr.392	PC12	0	Analog monitor 2 offset	10392	10692	10992	11292	11592	11892
Pr.393	PC13	0	Analog monitor feedback position output standard data Low	10393	10693	10993	11293	11593	11893
Pr.394	PC14	0	Analog monitor feedback position output standard data High	10394	10694	10994	11294	11594	11894

Buffer memory address											Memory area
Axis 7	Axis 8	Axis 9	Axis 10	Axis 11	Axis 12	Axis 13	Axis 14	Axis 15	Axis 16		
12153	12453	12753	13053	13353	13653	13953	14253	14553	14853	Gain/filter parameters	
12154	12454	12754	13054	13354	13654	13954	14254	14554	14854		
12155	12455	12755	13055	13355	13655	13955	14255	14555	14855		
12156	12456	12756	13056	13356	13656	13956	14256	14556	14856		
12157	12457	12757	13057	13357	13657	13957	14257	14557	14857		
12158	12458	12758	13058	13358	13658	13958	14258	14558	14858		
12159	12459	12759	13059	13359	13659	13959	14259	14559	14859		
12160	12460	12760	13060	13360	13660	13960	14260	14560	14860		
12161	12461	12761	13061	13361	13661	13961	14261	14561	14861		
12162	12462	12762	13062	13362	13662	13962	14262	14562	14862		
12163	12463	12763	13063	13363	13663	13963	14263	14563	14863		
12164	12464	12764	13064	13364	13664	13964	14264	14564	14864		
12165	12465	12765	13065	13365	13665	13965	14265	14565	14865		
12166	12466	12766	13066	13366	13666	13966	14266	14566	14866		
12167	12467	12767	13067	13367	13667	13967	14267	14567	14867		
12168	12468	12768	13068	13368	13668	13968	14268	14568	14868		
12169	12469	12769	13069	13369	13669	13969	14269	14569	14869		
12170	12470	12770	13070	13370	13670	13970	14270	14570	14870		
12171	12471	12771	13071	13371	13671	13971	14271	14571	14871		
12172	12472	12772	13072	13372	13672	13972	14272	14572	14872		
12173	12473	12773	13073	13373	13673	13973	14273	14573	14873		
12174	12474	12774	13074	13374	13674	13974	14274	14574	14874		
12175	12475	12775	13075	13375	13675	13975	14275	14575	14875		
12176	12476	12776	13076	13376	13676	13976	14276	14576	14876		
12177	12477	12777	13077	13377	13677	13977	14277	14577	14877		
12181	12481	12781	13081	13381	13681	13981	14281	14581	14881		
12182	12482	12782	13082	13382	13682	13982	14282	14582	14882		
12183	12483	12783	13083	13383	13683	13983	14283	14583	14883		
12184	12484	12784	13084	13384	13684	13984	14284	14584	14884		
12185	12485	12785	13085	13385	13685	13985	14285	14585	14885		
12186	12486	12786	13086	13386	13686	13986	14286	14586	14886		
12187	12487	12787	13087	13387	13687	13987	14287	14587	14887		
12188	12488	12788	13088	13388	13688	13988	14288	14588	14888		
12189	12489	12789	13089	13389	13689	13989	14289	14589	14889		
12190	12490	12790	13090	13390	13690	13990	14290	14590	14890		
12191	12491	12791	13091	13391	13691	13991	14291	14591	14891		
12192	12492	12792	13092	13392	13692	13992	14292	14592	14892		
12193	12493	12793	13093	13393	13693	13993	14293	14593	14893		
12194	12494	12794	13094	13394	13694	13994	14294	14594	14894		

Gain/filter parameters

Servo parameter area

Extension setting parameters

Symbol	No.	Default value	Item	Buffer memory address					
				Axis 1	Axis 2	Axis 3	Axis 4	Axis 5	Axis 6
Pr.395	PC15	0	For manufacturer setting	10395	10695	10995	11295	11595	11895
Pr.396	PC16	0000h		10396	10696	10996	11296	11596	11896
Pr.397	PC17	0000h	Function selection C-4	10397	10697	10997	11297	11597	11897
Pr.398	PC18	0000h	For manufacturer setting	10398	10698	10998	11298	11598	11898
Pr.399	PC19	0000h		10399	10699	10999	11299	11599	11899
Pr.400	PC20	0000h		10400	10700	11000	11300	11600	11900
Pr.401	PC21	0000h		Alarm history clear	10401	10701	11001	11301	11601
Pr.402	PC22	0000h	For manufacturer setting	10402	10702	11002	11302	11602	11902
Pr.403	PC23	0000h		10403	10703	11003	11303	11603	11903
Pr.404	PC24	0000h		10404	10704	11004	11304	11604	11904
Pr.405	PC25	0000h		10405	10705	11005	11305	11605	11905
Pr.406	PC26	0000h		10406	10706	11006	11306	11606	11906
Pr.407	PC27	0000h		10407	10707	11007	11307	11607	11907
Pr.408	PC28	0000h		10408	10708	11008	11308	11608	11908
Pr.409	PC29	0000h		10409	10709	11009	11309	11609	11909
Pr.410	PC30	0000h		10410	10710	11010	11310	11610	11910
Pr.411	PC31	0000h		10411	10711	11011	11311	11611	11911
Pr.412	PC32	0000h		10412	10712	11012	11312	11612	11912
Pr.413	PD01	0000h		10413	10713	11013	11313	11613	11913
Pr.414	PD02	0000h		10414	10714	11014	11314	11614	11914
Pr.415	PD03	0000h		10415	10715	11015	11315	11615	11915
Pr.416	PD04	0000h		10416	10716	11016	11316	11616	11916
Pr.417	PD05	0000h		10417	10717	11017	11317	11617	11917
Pr.418	PD06	0000h	10418	10718	11018	11318	11618	11918	
Pr.419	PD07	0005h	Output signal device selection 1	10419	10719	11019	11319	11619	11919
Pr.420	PD08	0004h	Output signal device selection 2	10420	10720	11020	11320	11620	11920
Pr.421	PD09	0003h	Output signal device selection 3	10421	10721	11021	11321	11621	11921
Pr.422	PD10	0000h	For manufacturer setting	10422	10722	11022	11322	11622	11922
Pr.423	PD11	0004h		10423	10723	11023	11323	11623	11923
Pr.424	PD12	0000h		10424	10724	11024	11324	11624	11924
Pr.425	PD13	0000h		10425	10725	11025	11325	11625	11925
Pr.426	PD14	0000h	Function selection D-3	10426	10726	11026	11326	11626	11926
Pr.427	PD15	0000h	For manufacturer setting	10427	10727	11027	11327	11627	11927
Pr.428	PD16	0000h		10428	10728	11028	11328	11628	11928
Pr.429	PD17	0000h		10429	10729	11029	11329	11629	11929
Pr.430	PD18	0000h		10430	10730	11030	11330	11630	11930
Pr.431	PD19	0000h		10431	10731	11031	11331	11631	11931
Pr.432	PD20	0000h		10432	10732	11032	11332	11632	11932
Pr.433	PD21	0000h		10433	10733	11033	11333	11633	11933
Pr.434	PD22	0000h		10434	10734	11034	11334	11634	11934
Pr.435	PD23	0000h		10435	10735	11035	11335	11635	11935
Pr.436	PD24	0000h		10436	10736	11036	11336	11636	11936
Pr.437	PD25	0000h		10437	10737	11037	11337	11637	11937
Pr.438	PD26	0000h		10438	10738	11038	11338	11638	11938
Pr.439	PD27	0000h		10439	10739	11039	11339	11639	11939
Pr.440	PD28	0000h		10440	10740	11040	11340	11640	11940
Pr.441	PD29	0000h		10441	10741	11041	11341	11641	11941
Pr.442	PD30	0000h		10442	10742	11042	11342	11642	11942
Pr.443	PD31	0000h		10443	10743	11043	11343	11643	11943
Pr.444	PD32	0000h		10444	10744	11044	11344	11644	11944

	Buffer memory address										Memory area
	Axis 7	Axis 8	Axis 9	Axis 10	Axis 11	Axis 12	Axis 13	Axis 14	Axis 15	Axis 16	
12195	12495	12795	13095	13395	13695	13995	14295	14595	14895		
12196	12496	12796	13096	13396	13696	13996	14296	14596	14896		
12197	12497	12797	13097	13397	13697	13997	14297	14597	14897		
12198	12498	12798	13098	13398	13698	13998	14298	14598	14898		
12199	12499	12799	13099	13399	13699	13999	14299	14599	14899		
12200	12500	12800	13100	13400	13700	14000	14300	14600	14900	Extension setting parameters	
12201	12501	12801	13101	13401	13701	14001	14301	14601	14901		
12202	12502	12802	13102	13402	13702	14002	14302	14602	14902		
12203	12503	12803	13103	13403	13703	14003	14303	14603	14903		
12204	12504	12804	13104	13404	13704	14004	14304	14604	14904		
12205	12505	12805	13105	13405	13705	14005	14305	14605	14905		
12206	12506	12806	13106	13406	13706	14006	14306	14606	14906		
12207	12507	12807	13107	13407	13707	14007	14307	14607	14907		
12208	12508	12808	13108	13408	13708	14008	14308	14608	14908		
12209	12509	12809	13109	13409	13709	14009	14309	14609	14909		
12210	12510	12810	13110	13410	13710	14010	14310	14610	14910		
12211	12511	12811	13111	13411	13711	14011	14311	14611	14911		
12212	12512	12812	13112	13412	13712	14012	14312	14612	14912		
12213	12513	12813	13113	13413	13713	14013	14313	14613	14913		
12214	12514	12814	13114	13414	13714	14014	14314	14614	14914		
12215	12515	12815	13115	13415	13715	14015	14315	14615	14915		
12216	12516	12816	13116	13416	13716	14016	14316	14616	14916		
12217	12517	12817	13117	13417	13717	14017	14317	14617	14917		
12218	12518	12818	13118	13418	13718	14018	14318	14618	14918		
12219	12519	12819	13119	13419	13719	14019	14319	14619	14919		
12220	12520	12820	13120	13420	13720	14020	14320	14620	14920		
12221	12521	12821	13121	13421	13721	14021	14321	14621	14921		
12222	12522	12822	13122	13422	13722	14022	14322	14622	14922		
12223	12523	12823	13123	13423	13723	14023	14323	14623	14923		
12224	12524	12824	13124	13424	13724	14024	14324	14624	14924		
12225	12525	12825	13125	13425	13725	14025	14325	14625	14925		
12226	12526	12826	13126	13426	13726	14026	14326	14626	14926		
12227	12527	12827	13127	13427	13727	14027	14327	14627	14927		
12228	12528	12828	13128	13428	13728	14028	14328	14628	14928		
12229	12529	12829	13129	13429	13729	14029	14329	14629	14929		
12230	12530	12830	13130	13430	13730	14030	14330	14630	14930		
12231	12531	12831	13131	13431	13731	14031	14331	14631	14931		
12232	12532	12832	13132	13432	13732	14032	14332	14632	14932		
12233	12533	12833	13133	13433	13733	14033	14333	14633	14933		
12234	12534	12834	13134	13434	13734	14034	14334	14634	14934		
12235	12535	12835	13135	13435	13735	14035	14335	14635	14935		
12236	12536	12836	13136	13436	13736	14036	14336	14636	14936		
12237	12537	12837	13137	13437	13737	14037	14337	14637	14937		
12238	12538	12838	13138	13438	13738	14038	14338	14638	14938		
12239	12539	12839	13139	13439	13739	14039	14339	14639	14939		
12240	12540	12840	13140	13440	13740	14040	14340	14640	14940		
12241	12541	12841	13141	13441	13741	14041	14341	14641	14941		
12242	12542	12842	13142	13442	13742	14042	14342	14642	14942		
12243	12543	12843	13143	13443	13743	14043	14343	14643	14943		
12244	12544	12844	13144	13444	13744	14044	14344	14644	14944		

Extension setting parameters

Servo parameter area

I/O setting parameters

Symbol	No.	Default value	Item	Buffer memory address						
				Axis 1	Axis 2	Axis 3	Axis 4	Axis 5	Axis 6	
Pr.445	PE01	0000h	For manufacturer setting	10445	10745	11045	11345	11645	11945	
Pr.446	PE02	0102h		10446	10746	11046	11346	11646	11946	
Pr.447	PE03	0002h		10447	10747	11047	11347	11647	11947	
Pr.448	PE04	1		10448	10748	11048	11348	11648	11948	
Pr.449	PE05	1		10449	10749	11049	11349	11649	11949	
Pr.450	PE06	400		10450	10750	11050	11350	11650	11950	
Pr.451	PE07	100		10451	10751	11051	11351	11651	11951	
Pr.452	PE08	10		10452	10752	11052	11352	11652	11952	
Pr.453	PE09	0000h		10453	10753	11053	11353	11653	11953	
Pr.454	PE10	0000h		10454	10754	11054	11354	11654	11954	
Pr.455	PE11	0		10455	10755	11055	11355	11655	11955	
Pr.456	PE12	40		10456	10756	11056	11356	11656	11956	
Pr.457	PE13	FFFEh		10457	10757	11057	11357	11657	11957	
Pr.458	PE14	0111h		10458	10758	11058	11358	11658	11958	
Pr.459	PE15	20		10459	10759	11059	11359	11659	11959	
Pr.460	PE16	0000h		10460	10760	11060	11360	11660	11960	
Pr.461	PE17	0000h		10461	10761	11061	11361	11661	11961	
Pr.462	PE18	0000h		10462	10762	11062	11362	11662	11962	
Pr.463	PE19	0000h		10463	10763	11063	11363	11663	11963	
Pr.464	PE20	0000h		10464	10764	11064	11364	11664	11964	
Pr.465	PE21	0000h		10465	10765	11065	11365	11665	11965	
Pr.466	PE22	0000h		10466	10766	11066	11366	11666	11966	
Pr.467	PE23	0000h		10467	10767	11067	11367	11667	11967	
Pr.468	PE24	0000h		10468	10768	11068	11368	11668	11968	
Pr.469	PE25	0000h		10469	10769	11069	11369	11669	11969	
Pr.470	PE26	0000h	Filter coefficient 2-1	10470	10770	11070	11370	11670	11970	
Pr.471	PE27	0000h	Filter coefficient 2-2	10471	10771	11071	11371	11671	11971	
Pr.472	PE28	0000h	Filter coefficient 2-3	10472	10772	11072	11372	11672	11972	
Pr.473	PE29	0000h	Filter coefficient 2-4	10473	10773	11073	11373	11673	11973	
Pr.474	PE30	0000h	Filter coefficient 2-5	10474	10774	11074	11374	11674	11974	
Pr.475	PE31	0000h	Filter coefficient 2-6	10475	10775	11075	11375	11675	11975	
Pr.476	PE32	0000h	Filter coefficient 2-7	10476	10776	11076	11376	11676	11976	
Pr.477	PE33	0000h	Filter coefficient 2-8	10477	10777	11077	11377	11677	11977	
Pr.478	PE34	0	For manufacturer setting	10478	10778	11078	11378	11678	11978	
Pr.479	PE35	0		10479	10779	11079	11379	11679	11979	
Pr.480	PE36	0		10480	10780	11080	11380	11680	11980	
Pr.481	PE37	0		10481	10781	11081	11381	11681	11981	
Pr.482	PE38	0		10482	10782	11082	11382	11682	11982	
Pr.483	PE39	0		10483	10783	11083	11383	11683	11983	
Pr.484	PE40	0		10484	10784	11084	11384	11684	11984	
Pr.493	PS01	0		10493	10793	11093	11393	11693	11993	
Pr.494	PS02	0		10494	10794	11094	11394	11694	11994	
Pr.495	PS03	0		10495	10795	11095	11395	11695	11995	
Pr.496	PS04	0		10496	10796	11096	11396	11696	11996	
Pr.497	PS05	0		10497	10797	11097	11397	11697	11997	
Pr.498	PS06	0		10498	10798	11098	11398	11698	11998	
Pr.499	PS07	0		10499	10799	11099	11399	11699	11999	
Pr.500	PS08	0	10500	10800	11100	11400	11700	12000		
Pr.501	PS09	0	10501	10801	11101	11401	11701	12001		

Buffer memory address											Memory area
Axis 7	Axis 8	Axis 9	Axis 10	Axis 11	Axis 12	Axis 13	Axis 14	Axis 15	Axis 16		
12245	12545	12845	13145	13445	13745	14045	14345	14645	14945	Extension control parameters	
12246	12546	12846	13146	13446	13746	14046	14346	14646	14946		
12247	12547	12847	13147	13447	13747	14047	14347	14647	14947		
12248	12548	12848	13148	13448	13748	14048	14348	14648	14948		
12249	12549	12849	13149	13449	13749	14049	14349	14649	14949		
12250	12550	12850	13150	13450	13750	14050	14350	14650	14950		
12251	12551	12851	13151	13451	13751	14051	14351	14651	14951		
12252	12552	12852	13152	13452	13752	14052	14352	14652	14952		
12253	12553	12853	13153	13453	13753	14053	14353	14653	14953		
12254	12554	12854	13154	13454	13754	14054	14354	14654	14954		
12255	12555	12855	13155	13455	13755	14055	14355	14655	14955		
12256	12556	12856	13156	13456	13756	14056	14356	14656	14956		
12257	12557	12857	13157	13457	13757	14057	14357	14657	14957		
12258	12558	12858	13158	13458	13758	14058	14358	14658	14958		
12259	12559	12859	13159	13459	13759	14059	14359	14659	14959		
12260	12560	12860	13160	13460	13760	14060	14360	14660	14960		
12261	12561	12861	13161	13461	13761	14061	14361	14661	14961		
12262	12562	12862	13162	13462	13762	14062	14362	14662	14962		
12263	12563	12863	13163	13463	13763	14063	14363	14663	14963		
12264	12564	12864	13164	13464	13764	14064	14364	14664	14964		
12265	12565	12865	13165	13465	13765	14065	14365	14665	14965		
12266	12566	12866	13166	13466	13766	14066	14366	14666	14966		
12267	12567	12867	13167	13467	13767	14067	14367	14667	14967		
12268	12568	12868	13168	13468	13768	14068	14368	14668	14968		
12269	12569	12869	13169	13469	13769	14069	14369	14669	14969		
12270	12570	12870	13170	13470	13770	14070	14370	14670	14970		
12271	12571	12871	13171	13471	13771	14071	14371	14671	14971		
12272	12572	12872	13172	13472	13772	14072	14372	14672	14972		
12273	12573	12873	13173	13473	13773	14073	14373	14673	14973		
12274	12574	12874	13174	13474	13774	14074	14374	14674	14974		
12275	12575	12875	13175	13475	13775	14075	14375	14675	14975		
12276	12576	12876	13176	13476	13776	14076	14376	14676	14976		
12277	12577	12877	13177	13477	13777	14077	14377	14677	14977		
12278	12578	12878	13178	13478	13778	14078	14378	14678	14978		
12279	12579	12879	13179	13479	13779	14079	14379	14679	14979		
12280	12580	12880	13180	13480	13780	14080	14380	14680	14980		
12281	12581	12881	13181	13481	13781	14081	14381	14681	14981		
12282	12582	12882	13182	13482	13782	14082	14382	14682	14982		
12283	12583	12883	13183	13483	13783	14083	14383	14683	14983		
12284	12584	12884	13184	13484	13784	14084	14384	14684	14984		
12293	12593	12893	13193	13493	13793	14093	14393	14693	14993		
12294	12594	12894	13194	13494	13794	14094	14394	14694	14994		
12295	12595	12895	13195	13495	13795	14095	14395	14695	14995		
12296	12596	12896	13196	13496	13796	14096	14396	14696	14996		
12297	12597	12897	13197	13497	13797	14097	14397	14697	14997		
12298	12598	12898	13198	13498	13798	14098	14398	14698	14998		
12299	12599	12899	13199	13499	13799	14099	14399	14699	14999		
12300	12600	12900	13200	13500	13800	14100	14400	14700	15000		
12301	12601	12901	13201	13501	13801	14101	14401	14701	15001		

Extension control parameters

Servo parameter area

Special setting parameters

Symbol	No.	Default value	Item	Buffer memory address						
				Axis 1	Axis 2	Axis 3	Axis 4	Axis 5	Axis 6	
Pr.502	PS10	0	For manufacturer setting	10502	10802	11102	11402	11702	12002	
Pr.503	PS11	0		10503	10803	11103	11403	11703	12003	
Pr.504	PS12	0		10504	10804	11104	11404	11704	12004	
Pr.505	PS13	0		10505	10805	11105	11405	11705	12005	
Pr.506	PS14	0		10506	10806	11106	11406	11706	12006	
Pr.507	PS15	0		10507	10807	11107	11407	11707	12007	
Pr.508	PS16	0		10508	10808	11108	11408	11708	12008	
Pr.509	PS17	0		10509	10809	11109	11409	11709	12009	
Pr.510	PS18	0		10510	10810	11110	11410	11710	12010	
Pr.511	PS19	0		10511	10811	11111	11411	11711	12011	
Pr.512	PS20	0		10512	10812	11112	11412	11712	12012	
Pr.513	PS21	0		10513	10813	11113	11413	11713	12013	
Pr.514	PS22	0		10514	10814	11114	11414	11714	12014	
Pr.515	PS23	0		10515	10815	11115	11415	11715	12015	
Pr.516	PS24	0		10516	10816	11116	11416	11716	12016	
Pr.517	PS25	0		10517	10817	11117	11417	11717	12017	
Pr.518	PS26	0		10518	10818	11118	11418	11718	12018	
Pr.519	PS27	0		10519	10819	11119	11419	11719	12019	
Pr.520	PS28	0		10520	10820	11120	11420	11720	12020	
Pr.521	PS29	0		10521	10821	11121	11421	11721	12021	
Pr.522	PS30	0		10522	10822	11122	11422	11722	12022	
Pr.523	PS31	0		10523	10823	11123	11423	11723	12023	
Pr.524	PS32	0		10524	10824	11124	11424	11724	12024	
Pr.525	PF1	0		10525	10825	11125	11425	11725	12025	
Pr.526	PF2	0		10526	10826	11126	11426	11726	12026	
Pr.527	PF3	0		10527	10827	11127	11427	11727	12027	
Pr.528	PF4	0		10528	10828	11128	11428	11728	12028	
Pr.529	PF5	0		10529	10829	11129	11429	11729	12029	
Pr.530	PF6	0		10530	10830	11130	11430	11730	12030	
Pr.531	PF7	0		10531	10831	11131	11431	11731	12031	
Pr.532	PF8	0		10532	10832	11132	11432	11732	12032	
Pr.533	PF9	10000		10533	10833	11133	11433	11733	12033	
Pr.534	PF10	100		10534	10834	11134	11434	11734	12034	
Pr.535	PF11	100		10535	10835	11135	11435	11735	12035	
Pr.536	PF12	100		10536	10836	11136	11436	11736	12036	
Pr.537	PF13	0		10537	10837	11137	11437	11737	12037	
Pr.538	PF14	10		10538	10838	11138	11438	11738	12038	
Pr.539	PF15	0		10539	10839	11139	11439	11739	12039	
Pr.540	PF16	0		10540	10840	11140	11440	11740	12040	
Pr.541	PO1	0		10541	10841	11141	11441	11741	12041	
Pr.542	PO2	0		10542	10842	11142	11442	11742	12042	
Pr.543	PO3	0		10543	10843	11143	11443	11743	12043	
Pr.544	PO4	0		10544	10844	11144	11444	11744	12044	
Pr.545	PO5	0		10545	10845	11145	11445	11745	12045	
Pr.546	PO6	0		10546	10846	11146	11446	11746	12046	
Pr.547	PO7	0		10547	10847	11147	11447	11747	12047	
Pr.548	PO8	0		10548	10848	11148	11448	11748	12048	
Pr.549	PO9	0		10549	10849	11149	11449	11749	12049	

	Buffer memory address										Memory area
	Axis 7	Axis 8	Axis 9	Axis 10	Axis 11	Axis 12	Axis 13	Axis 14	Axis 15	Axis 16	
12302	12602	12902	13202	13502	13802	14102	14402	14702	15002	Special setting parameters	Servo parameter area
12303	12603	12903	13203	13503	13803	14103	14403	14703	15003		
12304	12604	12904	13204	13504	13804	14104	14404	14704	15004		
12305	12605	12905	13205	13505	13805	14105	14405	14705	15005		
12306	12606	12906	13206	13506	13806	14106	14406	14706	15006		
12307	12607	12907	13207	13507	13807	14107	14407	14707	15007		
12308	12608	12908	13208	13508	13808	14108	14408	14708	15008		
12309	12609	12909	13209	13509	13809	14109	14409	14709	15009		
12310	12610	12910	13210	13510	13810	14110	14410	14710	15010		
12311	12611	12911	13211	13511	13811	14111	14411	14711	15011		
12312	12612	12912	13212	13512	13812	14112	14412	14712	15012		
12313	12613	12913	13213	13513	13813	14113	14413	14713	15013		
12314	12614	12914	13214	13514	13814	14114	14414	14714	15014		
12315	12615	12915	13215	13515	13815	14115	14415	14715	15015		
12316	12616	12916	13216	13516	13816	14116	14416	14716	15016		
12317	12617	12917	13217	13517	13817	14117	14417	14717	15017		
12318	12618	12918	13218	13518	13818	14118	14418	14718	15018		
12319	12619	12919	13219	13519	13819	14119	14419	14719	15019		
12320	12620	12920	13220	13520	13820	14120	14420	14720	15020		
12321	12621	12921	13221	13521	13821	14121	14421	14721	15021		
12322	12622	12922	13222	13522	13822	14122	14422	14722	15022		
12323	12623	12923	13223	13523	13823	14123	14423	14723	15023		
12324	12624	12924	13224	13524	13824	14124	14424	14724	15024		
12325	12625	12925	13225	13525	13825	14125	14425	14725	15025		
12326	12626	12926	13226	13526	13826	14126	14426	14726	15026		
12327	12627	12927	13227	13527	13827	14127	14427	14727	15027		
12328	12628	12928	13228	13528	13828	14128	14428	14728	15028		
12329	12629	12929	13229	13529	13829	14129	14429	14729	15029		
12330	12630	12930	13230	13530	13830	14130	14430	14730	15030		
12331	12631	12931	13231	13531	13831	14131	14431	14731	15031		
12332	12632	12932	13232	13532	13832	14132	14432	14732	15032		
12333	12633	12933	13233	13533	13833	14133	14433	14733	15033		
12334	12634	12934	13234	13534	13834	14134	14434	14734	15034		
12335	12635	12935	13235	13535	13835	14135	14435	14735	15035		
12336	12636	12936	13236	13536	13836	14136	14436	14736	15036		
12337	12637	12937	13237	13537	13837	14137	14437	14737	15037		
12338	12638	12938	13238	13538	13838	14138	14438	14738	15038		
12339	12639	12939	13239	13539	13839	14139	14439	14739	15039		
12340	12640	12940	13240	13540	13840	14140	14440	14740	15040		
12341	12641	12941	13241	13541	13841	14141	14441	14741	15041		
12342	12642	12942	13242	13542	13842	14142	14442	14742	15042		
12343	12643	12943	13243	13543	13843	14143	14443	14743	15043		
12344	12644	12944	13244	13544	13844	14144	14444	14744	15044		
12345	12645	12945	13245	13545	13845	14145	14445	14745	15045		
12346	12646	12946	13246	13546	13846	14146	14446	14746	15046		
12347	12647	12947	13247	13547	13847	14147	14447	14747	15047		
12348	12648	12948	13248	13548	13848	14148	14448	14748	15048		
12349	12649	12949	13249	13549	13849	14149	14449	14749	15049		

Symbol	No.	Default value	Item	Buffer memory address						
				Axis 1	Axis 2	Axis 3	Axis 4	Axis 5	Axis 6	
Pr.550	PO10	0	For manufacturer setting	10550	10850	11150	11450	11750	12050	
Pr.551	PO11	0		10551	10851	11151	11451	11751	12051	
Pr.552	PO12	0		10552	10852	11152	11452	11752	12052	
Pr.553	PO13	0		10553	10853	11153	11453	11753	12053	
Pr.554	PO14	0		10554	10854	11154	11454	11754	12054	
Pr.555	PO15	0		10555	10855	11155	11455	11755	12055	
Pr.556	PO16	0		10556	10856	11156	11456	11756	12056	

Buffer memory address											Memory area	
Axis 7	Axis 8	Axis 9	Axis 10	Axis 11	Axis 12	Axis 13	Axis 14	Axis 15	Axis 16			
12350	12650	12950	13250	13550	13850	14150	14450	14750	15050	Option unit	Servo parameter area	
12351	12651	12951	13251	13551	13851	14151	14451	14751	15051			
12352	12652	12952	13252	13552	13852	14152	14452	14752	15052			
12353	12653	12953	13253	13553	13853	14153	14453	14753	15053			
12354	12654	12954	13254	13554	13854	14154	14454	14754	15054			
12355	12655	12955	13255	13555	13855	14155	14455	14755	15055			
12356	12656	12956	13256	13556	13856	14156	14456	14756	15056			

WARRANTY

Please confirm the following product warranty details before using this product.

1. Gratis Warranty Term and Gratis Warranty Range

If any faults or defects (hereinafter "Failure") found to be the responsibility of Mitsubishi occurs during use of the product within the gratis warranty term, the product shall be repaired at no cost via the sales representative or Mitsubishi Service Company.

However, if repairs are required onsite at domestic or overseas location, expenses to send an engineer will be solely at the customer's discretion. Mitsubishi shall not be held responsible for any re-commissioning, maintenance, or testing on-site that involves replacement of the failed module.

[Gratis Warranty Term]

The gratis warranty term of the product shall be for one year after the date of purchase or delivery to a designated place.

Note that after manufacture and shipment from Mitsubishi, the maximum distribution period shall be six (6) months, and the longest gratis warranty term after manufacturing shall be eighteen (18) months. The gratis warranty term of repair parts shall not exceed the gratis warranty term before repairs.

[Gratis Warranty Range]

- (1) The range shall be limited to normal use within the usage state, usage methods and usage environment, etc., which follow the conditions and precautions, etc., given in the instruction manual, user's manual and caution labels on the product.
- (2) Even within the gratis warranty term, repairs shall be charged for in the following cases.
 1. Failure occurring from inappropriate storage or handling, carelessness or negligence by the user. Failure caused by the user's hardware or software design.
 2. Failure caused by unapproved modifications, etc., to the product by the user.
 3. When the Mitsubishi product is assembled into a user's device, Failure that could have been avoided if functions or structures, judged as necessary in the legal safety measures the user's device is subject to or as necessary by industry standards, had been provided.
 4. Failure that could have been avoided if consumable parts (battery, backlight, fuse, etc.) designated in the instruction manual have been correctly serviced or replaced.
 5. Failure caused by external irresistible forces such as fires or abnormal voltages, and Failure caused by force majeure such as earthquakes, lightning, wind and water damage.
 6. Failure caused by reasons unpredictable by scientific technology standards at time of shipment from Mitsubishi.
 7. Any other failure found to not be the responsibility of Mitsubishi or that admitted not to be so by the user.

2. Onerous repair term after discontinuation of production

- (1) Mitsubishi shall accept onerous product repairs for seven (7) years after production of the product is discontinued. Discontinuation of production shall be notified with Mitsubishi Technical Bulletins, etc.
- (2) Product supply (including repair parts) is not available after production is discontinued.

3. Overseas service

Overseas, repairs shall be accepted by Mitsubishi's local overseas FA Center. Note that the repair conditions at each FA Center may differ.

4. Exclusion of loss in opportunity and secondary loss from warranty liability

Regardless of the gratis warranty term, Mitsubishi shall not be liable for compensation to damages caused by any cause found not to be the responsibility of Mitsubishi, loss in opportunity, lost profits incurred to the user by Failures of Mitsubishi products, special damages and secondary damages whether foreseeable or not, compensation for damages to products other than Mitsubishi products, replacement by the user, maintenance of on-site equipment, start-up test run and other tasks.

5. Changes in product specifications

The specifications given in the catalogs, manuals or technical documents are subject to change without prior notice.

6. Product application

- (1) In using the Mitsubishi MELSEC programmable logic controller, the usage conditions shall be that the application will not lead to a major accident even if any problem or fault should occur in the programmable logic controller device, and that backup and fail-safe functions are systematically provided outside of the device for any problem or fault.
- (2) The Mitsubishi general-purpose programmable logic controller has been designed and manufactured for applications in general industries, etc. Thus, applications in which the public could be affected such as in nuclear power plants and other power plants operated by respective power companies, and applications in which a special quality assurance system is required, such as for Railways companies or Public service purposes shall be excluded from the programmable logic controller applications.

In addition, applications in which human life or property that could be greatly affected, such as in aircraft, medical applications, incineration and fuel devices, manned transportation, equipment for recreation and amusement, and safety devices, shall also be excluded from the programmable logic controller range of applications.

However, in certain cases, some applications may be possible, providing the user consults their local Mitsubishi representative outlining the special requirements of the projects, and providing that all parties concerned agree to the special circumstances, solely at the users discretion.

Microsoft Windows and Windows NT are registered trademarks of Microsoft Corporation in the United States and other countries.
Other company and product names herein may be either trademarks or registered trademarks of their respective owners.

IB(NA)-0300147-B(1112)MEE

MODEL: QD74MH-U-S-E

MODEL CODE: 1XB938

MITSUBISHI ELECTRIC CORPORATION

HEAD OFFICE : TOKYO BUILDING, 2-7-3 MARUNOUCHI, CHIYODA-KU, TOKYO 100-8310, JAPAN
NAGOYA WORKS : 1-14, YADA-MINAMI 5-CHOME, HIGASHI-KU, NAGOYA, JAPAN

When exported from Japan, this manual does not require application to the
Ministry of Economy, Trade and Industry for service transaction permission.

Specifications subject to change without notice.